

MANUAL**Model: PT 48 - 40**

Solar Converters Inc. - Rev. F

1.0 Specification

Note: This unit is a Multi - Voltage unit with adjustable input panel and output battery adjustment. Please review the section on Voltage Set-up Appendix A before connecting to this unit.

Connection: Power: max. AWG # 6 Eurostyle Terminal Strip
Signal: max. AWG # 14 Eurostyle Terminal Strip

Maximum power point tracking to optimize output power.

Charge Technique: Dual float. Unit charges to float voltage + 1.2 V @ 48 V, then drops to float voltage when charge current drops under 10%.

Optional Temperature compensation at -4 mv / deg °C / cell

Temperature range: -40 °C to + 60 °C

Efficiency: >94% over 20% charging load

No need for external blocking diode

Input Voltage Clamp

Drives for external Chrg and full indicators

Transient protected - input and output

NOTE: The battery is not fused in this unit. An external battery fuse is required.

SEE SECTION ON VOLTAGE SETUP

Mounting: The unit is to be mounted vertically. The unit is very efficient but does get warm. Vertical mounting allows cooling of the back of the heatsink.

Input Voltage: 0 - 90 V DC volts

Input load diversion set @ 90 V DC

Adjustable charge voltage: 40 - 60 V DC, factory set 56.2 V on 48 V setting

Current: 40 amps continuous, (provided sufficient solar power)

Integral LVD drive: LVD driver on @ 44.0 V, off @ 46 V referenced to a 48 V battery. This will adjust itself with the voltage adjustment of the BATSET Terminal.

Auxiliary drive: On @ float less 3%. Any time the battery voltage is less than float - 3%, the Auxiliary drive will be on to drive an external relay controlling an external charging device, or to drive a battery vent fan.

2.0 Power Connections

Warning: Before connecting power cable to this unit, evaluate the PV and battery voltage and set the unit voltage select accordingly - SEE APPENDIX A

Warning: This unit operates from multiple **Hazardous** energy sources. Ensure that all power sources are inactive before making any connections to this unit. Ensure proper procedures and the appropriate electrical codes are followed. To be serviced and operated only by qualified personnel.

2.1 Ground

Using wire of sufficient amperage (min. #8 AWG) connect the ground post (the back plate) of unit to appropriate system ground as required by the appropriate electrical code. Note this ground is not internally connected to any of the unit's terminals.

NOTE: When powering up the unit, apply battery voltage first. This prevents the output voltage from overshooting its regulation setpoint.

2.2 Battery Connection

Output voltage: 40 - 60 V DC CHECK VOLTAGE SETUP OF OUTPUT VOLTAGE

Output current: 0 -30 amps nominal,
(Total load = load current + battery current)

Warning: Ensure the battery is disconnected and/or safe operating procedures are followed when making battery connections. Extreme care must be taken to ensure the battery is not shorted. BE SAFE. Make sure all strands are inside their respective terminals. **The battery must be fused.** Qualified personnel only to connect and operate this unit.

Using wire of sufficient amperage for the battery connection #8 AWG or better (preferred for regulation) connect the positive of the battery (through the strain relief) to the positive battery connection of the solar regulator terminal block. Similarly connect the negative of the battery to the negative battery connection of the solar regulator terminal block.

2.3 Input Power Connection

Input voltage: 0 - 90 V DC MAX. CHECK VOLTAGE SET-UP OF INPUT VOLTAGE

Input current: 30 A DC max. Nominal

Using wire of sufficient amperage for the battery connection #8 AWG or better (preferred for regulation) connect the positive of the PV (through the strain relief) to the positive PV connection of the solar regulator terminal block. Similarly connect the negative of the PV to the negative PV connection of the solar regulator terminal block.

3.0 Signal Connection

3.1 Temperature Compensation

This regulator is designed to use the voltage of a temperature sensitive zener (National Semiconductor # LM335Z or equiv.) attached at the battery location (hence battery temperature). This unit is available from Solar Converters Inc. as Model No. TC-2.

Warning: If temperature compensation is not used, a 3k precision resistor must be connected between the TC+ and TC- terminals (its default condition). Lack of this resistor will not harm the regulator, but will require re-adjustment of the output voltage.

If temperature compensation is being used, remove the 3k resistor across terminals TC+ and TC-. Using a wire of sufficient amperage (#24 AWG or better) connect the TC+ terminal to the anode (the red lead) of the temperature sensitive zener. Similarly connect the TC- terminal to the cathode (the black lead) of the temperature sensitive zener (LM335Z).

3.2 LVD

The unit will drive an external LVD relay coil at up to 5 amps sourced from the battery. This signal should be setup up to drive open an external LVD relay when the battery voltage is too low. An external fly back diode is recommended across

the relay coil.

Using wire of sufficient gauge, connect the LVD relay coil from the battery + to the LVD terminal.

Voc: Battery Voltage

Current = 5 amps

3.3 AUX Terminals

The unit produces a small signal relay drive to power a large relay for auxiliary switching in a higher power array. This scheme uses the units advance PWM charge control technique to "finish" the charge on a battery in a very large power system. The unit power the AUX terminals to connect the other array at float voltage less 3%, to charge the battery, then as the battery voltage moves above float less 3%, it disconnects the other high power array, finishing the charging on the units MPPT PWM control. Another use of this AUX drive is to turn drives a battery fan vent.

Using wire of sufficient gauge, connect the relay coil to the AUX terminals. An external fly back diode is recommended across the relay coil. The unit applies battery voltage to the external relay.

Auxiliary drive: On @ float less 3%. Any time the battery voltage is less than float - 3%, the Auxiliary drive will be on to drive an external relay controlling an external charging device, like an second PV source, generator, wind generator etc.

Using wire of sufficient gauge, connect the AUX relay coil from the battery + to the AUX terminal.

Voltage: Battery voltage

Current: 5 amps

3.4 Diversion Load Terminals

The unit has a built in load diversion controller (INPUT VOLTAGE CLAMP) to shunt excess input voltage to a dump resistor.

It is recommend that the shunt resistor be sized to handle the anticipated excess power (times 1.5) that would be available at the elevated voltage. Note that all usual source PV, wind, and stream generators will produce higher voltage as load is removed from them, but the available power at this higher voltage is also reduced.

The unit is PWM; hence it will adjust itself to divert just enough energy to prevent the input voltage from exceeding its input specification to the maximum input voltage across the resistor.

Using wire of sufficient amperage for the anticipated current, connect a dump load resistor to the LD+ and LD- terminals. Excess power attempting to take the input voltage over 90 V will be shunted to this resistor.

Voltage 90 Vdc

Current 10 amps

3.5 Remote Control

The RC+ and RC- terminals are disabled on this unit.

4.0 Regulator Control Function

LEDs in the status section signal the status of the unit at any time. The status is also remotely signalled by the remote functions of the same name.

4.1 Chrg The unit is "MPPT" maximum current into the battery.

4.2 Full The output voltage/ battery voltage is at its prescribed maximum charge.

4.3 Float Setting

The "Float" voltage setting sets the regulation voltage of the regulator. The regulator will charge the battery at a voltage of the float voltage +1.2 V (relative to 48 V battery) while the battery current is above 10% charging current and the regulator will hold the battery at the float setting while the battery charge current is less than 10% of charging current. The default setting of this adjustment is 56.2 Volts relative to 48 V battery. The other voltage settings scale accordingly. The float voltage may be adjusted by measuring the test point voltage relative to PV- beside the float adjustment pot. This Pot is scaled such that 3 V equals the nominal battery voltage on the BATSET voltage selection.

A 12 V battery has a scale factor of 4, so adjust the voltage on the test point to be 1/4 your desired float voltage. A 24 V battery has a scale factor of 8 and a 48 V battery has a scale factor of 16. Using the scale factor adjust the float voltage to the desired level.

APPENDIX A **Voltage Setup**

To be performed by skilled personnel only. ENSURE POWER IS OFF BEFORE MAKING ANY ADJUSTMENTS TO THE UNIT.

The unit setup is easily accomplished by connecting jumpers into the appropriate spots.

Look for a label on the unit that says PXX and MXX, where XX is a number. This may mean the unit is a custom input or output and the XX represents what the unit is factory setup to run.

For example, P36 M36 would be a unit set up to run from 36 V panels and charge a 36 V battery.

Units that are not marked can be setup by adjusting the respective jumpers

There are 2 green connectors on the lower right of the unit. These are marked PVSET and BATSET.

Set Battery Voltage: The battery voltage the unit will charge is set by placing a jumper between the COM position and the respective battery voltage on the BATSET connector as shown on the units marking beside the terminal block. For example, a 12 V battery being charged would have its jumper placed between the COM and the 12 V position of the BATSET connector.

Set Panel Voltage: The panel voltage the unit will operate from is set by placing a jumper between the COM position and the respective panel voltage on the PVSET connector as shown on the units marking beside the terminal block. For example, a 12 V panel would have its jumper placed between the COM and the 12 V position of the PVSET connector.

PT 48-40

Solar Converters Inc. IMG# SP60-F_PCB

Remote Meter Connector

— Remote LED Drive

Indicator LEDs

— Used to adjust battery Full Charge Voltage

— Used to adjust Load Diversion set voltage

Used to adjust panel voltage

Set panel voltage Shown as 48 V

Set battery voltage Shown as 48 V

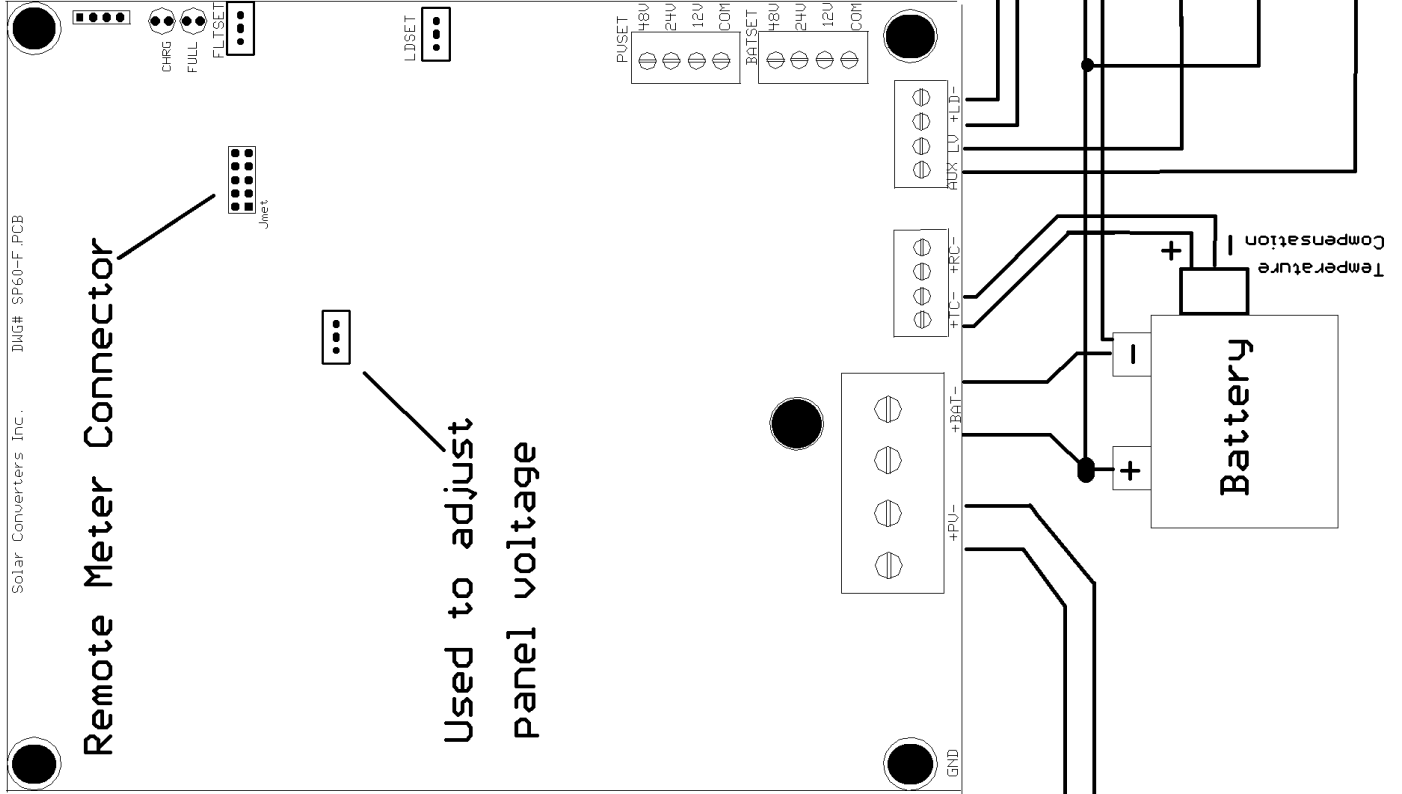

WARRANTY

The product is warranted to be free from defects in material and workmanship for a period of one (1) year from the date of purchase by a retail customer. The purchase date must be evidenced by a valid and original sales receipt. In lieu of sales receipt, factory will use code date on its label. Removal of the Solar Converters Inc. label or serial number will void the warranty.

Product liability, except where mandated by law, is limited to repair or replacement at the manufacturer's discretion. No specific claim of merchantability or use shall be assumed or implied beyond what is printed on the manufacturers printed literature. No liability shall exist from circumstances arising from the inability to use the product, or its inappropriateness for any specific purpose or actual use, or consequences thereof for any purpose. **It is the user's responsibility to determine the suitability of the product for any particular use.** Solar Converters Inc. shall not be liable for any damages or any kind including without limitation, special, incidental or consequential obligations and liabilities of Solar Converters Inc. and the remedies of Buyer set forth herein shall be Solar Converters Inc. sole and exclusive liability.

Failure to provide a safe and correct installation, safe operation, or care for the product will void the warranty. Personal safety, and compatibility with any other equipment is the ultimate responsibility of the end user. Any returned product that shows significant evidence of abuse may not be covered by this warranty. Installation must be performed by a person with qualification to insure safe and effective operation and the installation thereof certifies that the installer has the technical qualifications to do so.

Solar Converters Inc. cannot guarantee the compatibility of its products with other components used in conjunction with Solar Converters Inc. products, including, but not limited to, solar modules, batteries, and system interconnects, and such loads as inverters, transmitters and other loads which produce "noise" or electromagnetic interference, in excess of the levels to which Solar Converters Inc. products are compatible. Solar Converters Inc. shall not assume responsibility for any damages to any system components used in conjunction with Solar Converters Inc. products nor for claims for personal injury or property damage resulting from the use of Solar Converters Inc. products or the improper operation thereof or consequential damages arising from the products or use of the products.

The warranties set forth herein are Solar Converters Inc. sole and exclusive warranties for or relating to the goods. Seller neither makes nor assumes any warranty or merchantability, any warranty fitness for any particular purpose, or any other warranty of any kind, express, implied or statutory. Solar Converters Inc. neither assumes nor authorizes any person or entity to assume for it any other liability or obligation in connection with the sale or use of the goods, and there are no oral agreements or warranties collateral to or affecting the sale of the goods.

WARRANTY CLAIM PROCEDURE

In the event of product failure, follow this warranty claim procedure.

1. Make sure the problem you are having is actually due to the suspected product and not some other part of the system. You may call technical support for advanced troubleshooting assistance.
2. If you determine that a Solar Converters Inc. product is actually defective, describe on paper, in detail the exact nature of the failure.
3. The product must be accompanied by proof of the date of purchase satisfactory to Solar Converters Inc.
4. Return the product and description to the business office address, along with your address and a daytime phone number. Purchasers must prepay all delivery costs or shipping charges as well as any other charges encountered, in shipping any defective Solar Converters Inc. product under this warranty policy. **No shipment will be accepted Freight Collect.**
5. Any return shipment from Solar Converters Inc. will be via Canada Post. Foreign shipments will ship best way. Special shipping arrangements are available at the customer's expense.