

Smart choice for power

**xantrex**

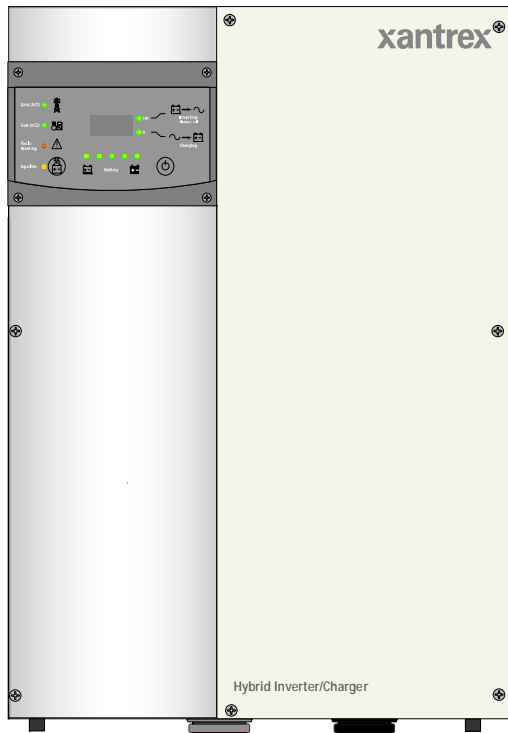

XW4024-230-50  
XW4548-230-50  
XW6048-230-50

**Operation Guide**

# XW Hybrid Inverter/Charger

[www.xantrex.com](http://www.xantrex.com)



Smart choice for power

**xantrex**

# **XW Hybrid Inverter/Charger**

## **Operation Guide**

## About Xantrex

Xantrex Technology Inc. is a world-leading supplier of advanced power electronics and controls with products from 50 watt mobile units to one MW utility-scale systems for wind, solar, batteries, fuel cells, microturbines, and backup power applications in both grid-connected and stand-alone systems. Xantrex products include inverters, battery chargers, programmable power supplies, and variable speed drives that convert, supply, control, clean, and distribute electrical power.

## Trademarks

XW Hybrid Inverter/Charger is a trademark of Xantrex International. Xantrex is a registered trademark of Xantrex International.

Other trademarks, registered trademarks, and product names are the property of their respective owners and are used herein for identification purposes only.

## Notice of Copyright

XW Hybrid Inverter/Charger Operation Guide © February 2008 Xantrex International. All rights reserved.

## Exclusion for Documentation

UNLESS SPECIFICALLY AGREED TO IN WRITING, XANTREX TECHNOLOGY INC. ("XANTREX")

(A) MAKES NO WARRANTY AS TO THE ACCURACY, SUFFICIENCY OR SUITABILITY OF ANY TECHNICAL OR OTHER INFORMATION PROVIDED IN ITS MANUALS OR OTHER DOCUMENTATION.

(B) ASSUMES NO RESPONSIBILITY OR LIABILITY FOR LOSSES, DAMAGES, COSTS OR EXPENSES, WHETHER SPECIAL, DIRECT, INDIRECT, CONSEQUENTIAL OR INCIDENTAL, WHICH MIGHT ARISE OUT OF THE USE OF SUCH INFORMATION. THE USE OF ANY SUCH INFORMATION WILL BE ENTIRELY AT THE USER'S RISK; AND

(C) REMINDS YOU THAT IF THIS MANUAL IS IN ANY LANGUAGE OTHER THAN ENGLISH, ALTHOUGH STEPS HAVE BEEN TAKEN TO MAINTAIN THE ACCURACY OF THE TRANSLATION, THE ACCURACY CANNOT BE GUARANTEED. APPROVED XANTREX CONTENT IS CONTAINED WITH THE ENGLISH LANGUAGE VERSION POSTED AT WWW.XANTREX.COM.

## Date and Revision

February 2008 Revision A

## Part Number

975-0385-01-01

## Product Number

865-1035 (XW6048-230-50), 865-1040 (XW4548-230-50), 865-1045 (XW4024-230-50)

## Contact Information

Telephone: +34 93 470 5330

Fax: +34 93 473 6093

Email: support.europe@xantrex.com

Web: www.xantrex.com

# About This Guide

## Purpose

The purpose of this Operation Guide is to provide explanations and procedures for configuring, operating, maintaining, and troubleshooting the XW Hybrid Inverter/Charger.

## Scope

This Guide includes information about monitoring and configuring the XW Inverter/Charger.

The Guide provides safety guidelines, detailed setup information, and information about operating and troubleshooting the unit. It does not provide installation procedures or details about particular brands of batteries, photoelectric cells, or generators. Consult the equipment manufacturers for this information.

## Audience

The Guide is intended for anyone who needs to operate, configure, and troubleshoot the XW Hybrid Inverter/Charger. Certain configuration tasks should only be performed in consultation with your local utility and/or an authorized dealer.

## Organization

This Guide is organized into four chapters and two appendices.

Chapter 1, “Introduction”, describes the operating features of the XW Hybrid Inverter/Charger.

Chapter 2, “Monitoring Operation”, contains information about monitoring XW Hybrid Inverter/Charger operation using the Inverter Information Panel or the XW System Control Panel.

Chapter 3, “Configuration” explains how to navigate through the XW System Control Panel menus and configure the XW Hybrid Inverter/Charger.

Chapter 4, “Troubleshooting”, contains information and procedures for identifying and solving possible problems with the XW Hybrid Inverter/Charger.

Appendix A, “Specifications” provides the electrical and mechanical specifications for the XW Hybrid Inverter/Charger.

Appendix B contains the default configuration settings and ranges for the XW Hybrid Inverter/Charger. Configuration settings can be viewed and changed using the XW System Control Panel.

## Conventions Used

The following conventions are used in this guide.



### **WARNING**

Warnings identify conditions or practices that could result in personal injury or loss of life.

---



### **CAUTION**

Cautions identify conditions or practices that could result in damage to the unit or other equipment.

---

**Important:** These notes describe things which are important for you to know, but not as serious as a caution or warning.

---

## Related Information

*Installation Guide* (975-0384-01-01).

You can find more information about Xantrex Technology Inc. as well as its products and services at **[www.xantrex.com](http://www.xantrex.com)**.

# Important Safety Instructions

## SAVE THESE INSTRUCTIONS

---



### WARNING

This chapter contains important safety and operating instructions. Read and keep this Operation Guide for future reference.

---



### WARNING: Limitations on use

The XW Hybrid Inverter/Charger is not intended for use in connection with life support systems or other medical equipment or devices.

---

1. Before using the XW Inverter/Charger, read all instructions and cautionary markings on the XW Inverter/Charger, the batteries, and all appropriate sections of this guide.
2. Ensure the XW Inverter/Charger is installed according to the guidelines and procedures in the separate Installation Guide.
3. Do not expose the XW Inverter/Charger to rain, snow, or spray. To reduce risk of fire, do not cover or obstruct the ventilation openings.
4. Use only attachments recommended or sold by Xantrex Technology. Doing otherwise may result in a risk of fire, electric shock, or injury to persons.
5. To avoid a risk of fire and electric shock, make sure that existing wiring is in good condition and that wire is not undersized. Do not operate the XW Inverter/Charger with damaged or substandard wiring.
6. Do not operate the XW Inverter/Charger if it has received a sharp blow, been dropped, or otherwise damaged in any way. If the XW Inverter/Charger is damaged, see the Warranty section.
7. Do not disassemble the XW Inverter/Charger. It contains no user-serviceable parts. See Warranty for instructions on obtaining service. Attempting to service the XW Inverter/Charger yourself may result in a risk of electrical shock or fire and will void your warranty. Internal capacitors remain charged after all power is disconnected.
8. To reduce the risk of electrical shock, authorized service personnel must disconnect both AC and DC power from the XW Inverter/Charger before attempting any maintenance or cleaning or working on any circuits connected to the XW Inverter/Charger. Turning off controls will not reduce this risk.
9. To reduce the chance of short-circuits, authorized service personnel must use insulated tools when installing or working with this equipment.





# Contents

<b>Important Safety Instructions</b>	v
<b>1 Introduction</b>	
Basic Features	1-2
Basic Operation	1-3
Surge Performance	1-4
Islanding Protection	1-5
Monitoring the Inverter	1-6
Inverter Information Panel	1-6
XW System Control Panel	1-7
<b>2 Monitoring Operation</b>	
Monitoring Operation with the Inverter Information Panel	2-2
Monitoring AC Input Status	2-2
Monitoring Inverter Status	2-3
Monitoring Charger Status	2-3
Monitoring Faults and Warnings	2-4
Equalizing Batteries	2-4
Turning the XW Inverter/Charger On and Off	2-5
Monitoring Battery Level	2-6
Reading the Display Screen	2-6
Monitoring Operation with the XW System Control Panel	2-7
XW System Control Panel Features	2-7
Using the Standby Button	2-8
System Control Panel Navigation	2-8
Viewing the System Control Panel Home Screens	2-8
Viewing Other Screens	2-10
Reading the System Status Screen	2-11
Reading the XW Inverter/Charger Home Screen	2-11
Reading the Meters Screen	2-13
<b>3 Configuration</b>	
Using the XW System Control Panel	3-2
XW Inverter/Charger Setup Menu	3-2
Setting the Time and Date	3-3
Using the Setup Menus	3-4
Inverter Settings Menu	3-7
Using the Low Battery Cut Out and LBCO Delay Settings	3-7
Using Search Mode	3-8

Charger Settings Menu	3-9
Battery Charger Functions	3-10
Multi-Stage Charging Process	3-10
Equalize Charging the Batteries	3-12
Using Charger Block	3-13
Custom Battery Settings Menu	3-14
AC Settings	3-15
Grid Support Settings	3-16
Energy Management	3-17
Charger Block	3-17
Grid Support	3-17
Grid Support and Battery Charging	3-18
Peak Load Shaving	3-18
Time-of-Use Metering	3-19
Generator Support Settings	3-20
Auxiliary Output Settings	3-21
Multi-Unit Config Menu	3-23
Setting the Device Name	3-23
Setting the Device Number	3-24
Three-Phase Configuration	3-25
Connections Menu	3-27
Copying Settings From Another Unit	3-28
Resetting the XW Inverter/Charger to Default Settings	3-29
Using the Advanced Features	3-29

## 4 Troubleshooting

General Troubleshooting Guidelines	4-2
Inverter Applications	4-3
Resistive Loads	4-3
Motor Loads	4-3
Problem Loads	4-3
Very Small Loads	4-3
Fluorescent Lights and Power Supplies	4-3
Clocks	4-4
Searching	4-4
Inverter Troubleshooting	4-5
Battery Charger Troubleshooting	4-8
Faults and Warnings	4-10
Warning Messages	4-10
Warning Types	4-11
Fault Messages	4-15
Fault Types	4-16
Inverter Operation After Faults	4-16

## A Specifications

Electrical Specifications	A-2
XW Inverter/Charger Overload Capability	A-3
Output Power Versus Ambient Temperature	A-4
XW Inverter/Charger Efficiency	A-4
Inverting Efficiency (Typical)	A-4
Charging Efficiency (Typical)	A-5
Charging Efficiency (Power Factor Corrected)	A-5
Grid-Tie Sell Mode Efficiency (Typical)	A-6
Mechanical Specifications	A-7
Accessories	A-7
Regulatory Approvals	A-8
Interconnect Codes and Standards	A-8

## B Default Settings

Default Settings and Ranges	B-2
Inverter Menu	B-3
Charger Menu	B-3
Custom Battery Menu	B-4
AC Menu	B-4
Grid Support Menu	B-5
Gen Support Menu	B-5
Aux Menu	B-6
Connections Menu	B-6

Warranty and Return Information	WA-1
---------------------------------	------

Index	IX-1
-------	------



# 1

## Introduction

Chapter 1, “Introduction”, describes the operating features of the XW Hybrid Inverter/Charger.

Topics in this chapter include:

- “Basic Features” on page 1–2
- “Basic Operation” on page 1–3

## Basic Features

The XW Hybrid Inverter/Charger is a true sine wave inverter/charger that can be used for residential and commercial applications: stand-alone, grid-backup, and grid-tie with battery energy storage. Capable of being grid-interactive or grid-independent, the XW Inverter/Charger will operate with generators and renewable energy sources to provide full-time or backup power.

Other XW Inverter/Charger features include:

- High efficiency true sine wave output
- Building block power levels—Up to three inverters can be installed together in a 230 volt, single-phase, two-wire configuration to produce up to 18 kilowatts. Multiple units can also be connected to create a three-phase system. At least one inverter per phase is required, and up to two inverters can be connected in parallel on each phase.
- Surge capacity to start difficult loads like well pumps, refrigerators or A/C compressors
- Power factor-corrected (PFC) input minimizes AC input current required for charging, increasing AC pass-through capacity
- High DC output current and multi-stage charger minimize charging time
- Optional XW Automatic Generator Start allows operation with a wide range of generators, supported through a dedicated generator input
- Supports multi-mode grid-tie operation
- Integrated transfer switch
- Temperature-controlled, variable-speed internal cooling fan. The fan turns on when the internal temperature reaches 45 °C and reaches maximum speed at 70 °C. The fan turns off when the internal temperature falls to 40 °C.
- Housing design promotes vertical air flow through the inverter. This natural “chimney effect” provides convection cooling at lower power levels, and reduces fan run time.
- Designed for reliability and field serviceability.

### System component



The XW Inverter/Charger uses Xanbus™, a network communications protocol developed by Xantrex, to communicate its settings and activity to other Xanbus-enabled devices. You can configure and monitor the XW Inverter/Charger and every Xanbus-enabled device in the system using an XW System Control Panel (part number 865-1050).

---

## Basic Operation

The XW Hybrid Inverter/Charger is a modular “building block” sine-wave inverter/charger that can be used for both residential and commercial stand-alone, grid-backup, and grid-tie applications with battery energy storage. The XW Inverter/Charger is a self-contained DC to AC inverter, battery charger and integrated AC transfer switch. All configurations must comply with local and national electrical codes.

### Multi-unit operation

**Inverting** For multiple XW Inverter/Chargers, the master inverter/charger broadcasts pulses on the Xanbus network to synchronize operation between the other paralleled units. When AC loads are present, all units produce power, effectively sharing the load. Multiple XW Inverter/Chargers do not produce power together when Search mode is enabled. See “Using Search Mode” on page 3–8.

**Parallel charging** Multiple XW Inverter/Chargers synchronize charging stages to ensure efficient charging of the battery bank. All units transition from bulk to absorption when a single unit does. In absorption, all units must complete the absorption stage before transitioning to the next stage. Note that units do not load share when charging except during the Bulk stage. The XW Inverter/Chargers stop sharing charge current just before completing the Bulk stage. The units do not share charge current during the Absorption and Float stages.

Each unit charges batteries based on the Max Charge Rate setting and active internal (temperature-based) deratings.

If equalize is enabled on one or more devices capable of equalization charging (such as XW Inverter/Chargers or XW Solar Charge Controllers), only those devices perform a equalize cycle after absorption. Other devices transition to float (if three-stage charging is selected) or transition to AC pass-through (if two-stage charging is selected).

When one or more XW Solar Charge Controllers are installed and operating in the system, the XW Inverter/Chargers synchronize charging stage (bulk, absorption, or float) with the charge controllers. In a similar fashion to the XW Inverter/Charger charge behavior, charge controllers also harmonize charging among themselves.

**AC Transfer** XW Inverter/Chargers monitor each other using a peer-to-peer monitoring technique to determine the quality of AC input. If AC input is deemed bad by any of the paralleled units, no transfer to AC occurs and the AC LED may continually flash on each unit’s Information Panel. If the system was in pass-through and AC fails on any unit, all units transfer to invert simultaneously.

**Faults** When an XW Inverter/Charger in a multi-unit system has a fault, only the affected device shuts down, except in the following cases:

- When a master unit has an invert mode fault that causes it to stop inverting, a system wide fault occurs. Invert mode faults on a slave unit shut down only the affected slave unit.
- Battery-related faults such as battery over-temperature or over-voltage.

**Other modes of operation** XW Inverter/Chargers operate independently when in grid support mode (including sell mode), load shave, generator support and charger block modes. This enables units to be configured to perform multiple functions independently and allows greater flexibility in operating the system. All configurations must comply with local and national electrical codes.

**Auxiliary output** Each XW Inverter/Charger has one programmable auxiliary output that is able to run a small 12 V fan or operate an external relay to perform other functions, such as to remotely start a generator (if the Xanbus-enabled XW-AGS is not used), to disconnect external non-critical loads, or to turn on a diversion load for battery voltage regulation.

**Transfer relay** The built-in transfer relay is rated for 60 amps. When an external AC source is detected on either of its two AC inputs, the switch transfers loads from the XW Inverter/Charger to the external power source, and then activates the battery charger.

**AC1 and AC2 relay** The XW Inverter/Charger design does not allow the AC1 and AC2 inputs to feed into each other. The relays controlling AC1 and AC2 input can never close simultaneously. This design prevents generator input from backfeeding to the utility grid.

## Surge Performance

Unlike many other inverters, the XW Inverter/Charger prevents voltage from sagging dramatically during surge conditions. The XW Inverter/Charger handles surges of over twice the inverter's rated output with only a minimal drop in output voltage.



---

## Islanding Protection

Islanding protection is an essential safety feature that ensures no person working on the utility grid is harmed by a distributed energy source, such as an XW Inverter/Charger. Islanding protection also prevents loads connected to the inverter from being damaged by fluctuating utility grid input.

The XW Inverter/Charger uses a proprietary positive feedback control to achieve reliable anti-islanding while maintaining low total harmonic distortion. Default software settings are programmed into each XW Inverter/Charger at the factory to ensure it does not “island” according to applicable safety regulations.

In some instances it may be desirable from both a utility and customer point of view to adjust default anti-islanding settings. For example, the XW Inverter/Charger may experience “nuisance trips” if the grid is weak and the voltage falls outside the allowable range specified in the regulations. It may be difficult for a utility to upgrade the grid to eliminate this problem. With permission from the utility, the factory settings may be changed to allow the XW Inverter/Charger to operate over a wider grid voltage range. These settings should only be changed by qualified service personnel, using a special software application provided by Xantrex. All configurations must comply with local and national electrical codes.

While selling power, the XW Inverter/Charger continuously monitors utility grid voltage and frequency. If the grid voltage and frequency move beyond the XW Inverter/Charger default ranges<sup>1</sup>—during a power surge or outage, for example—the XW Inverter/Charger stops selling power to AC1 and disconnects from the utility grid for five minutes. (Five minutes is the minimum reconnect time, and is not adjustable.) If the utility grid voltage and frequency have returned to their nominal values when the reconnect time has expired, the XW Inverter/Charger begins selling power again.

The Fault light on the XW Inverter/Charger Information Panel indicates a utility fault. No fault code appears on the three-character display because the fault is with the utility grid, not the XW Inverter/Charger.

The XW System Control Panel (SCP) indicates a utility fault with the Fault light and a fault message on its screen (faults F23 to F37 are utility faults—see Table 4-5 on page 4-18). The fault cannot be manually cleared. Utility faults clear automatically when the utility grid voltage and frequency return to within the ranges programmed into the XW Inverter/Charger.

---

1. See “Electrical Specifications” on page A-2.

## Monitoring the Inverter

You can monitor XW Inverter/Charger operation using the factory-installed Inverter Information Panel or an optional XW System Control Panel. You can configure the XW Inverter/Charger only with the System Control Panel.

### Inverter Information Panel

The Inverter Information Panel features:

- Buttons for XW Inverter/Charger on and off control, clearing faults and warnings, and battery equalization
- Three-character display to indicate power output, charge current or troubleshooting information
- LEDs to indicate inverter input status, inverter output status, battery condition, and system warnings or faults.

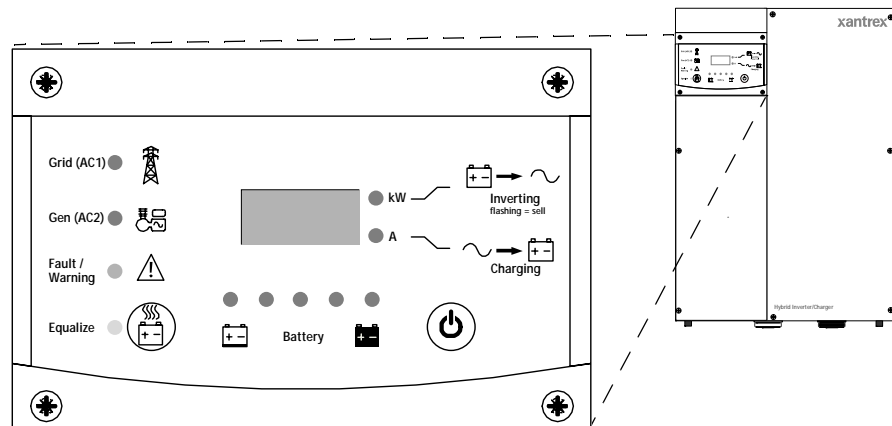

Figure 1-1 Inverter Information Panel

## XW System Control Panel

The XW System Control Panel is required for configuring the XW Inverter/Charger and other Xanbus-enabled system components.

The System Control Panel features:

- Liquid crystal display that provides graphics and text describing operation and status information in real time
- LED fault and warning indicator
- Internal clock to control time-dependent XW Inverter/Charger settings
- Buttons to select configuration menus, customize XW Inverter/Charger settings, and clear faults and warnings.

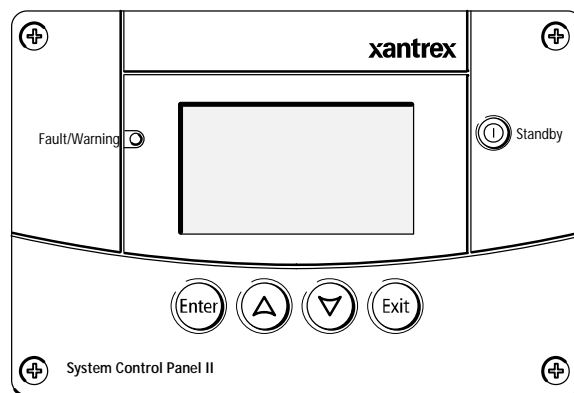

Figure 1-2 XW System Control Panel



# 2

## Monitoring Operation

Chapter 2, “Monitoring Operation”, contains information about monitoring XW Hybrid Inverter/Charger operation using the Inverter Information Panel or the XW System Control Panel.

Topics in this chapter include:

- “Monitoring Operation with the Inverter Information Panel” on page 2–2
- “Monitoring Operation with the XW System Control Panel” on page 2–7.

## Monitoring Operation with the Inverter Information Panel

The Inverter Information Panel monitors a single XW Inverter/Charger. The Inverter Information Panel displays basic information, allows you to turn the XW Inverter/Charger on and off and start battery equalization. LEDs on the Information Panel indicate AC input status, inverter status, battery condition, and charging and equalization status. The LEDs and three-character display screen also alert you to XW Inverter/Charger warning and fault conditions.

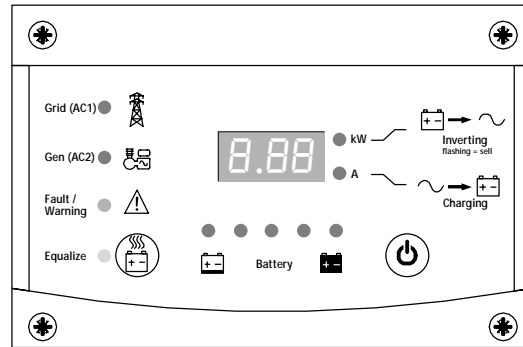



Figure 2-1 Inverter Information Panel

### Monitoring AC Input Status

**Grid (AC1)** The green Grid (AC1) LED indicates the presence and status of an AC source connected to the AC1 input.

Symbol	LED On	LED Flashing	LED Off
	AC input is present and qualified. The XW Inverter/Charger is ready to charge batteries, sell power to the grid, or pass AC through to the loads.	AC input is present, within nominal range and is being qualified.	The XW Inverter/Charger is not connected to the grid. AC input is not present, or AC input is present but not within nominal range.

**Gen (AC2)** The green Gen (AC2) LED indicates the presence and status of a generator or other auxiliary AC source on the AC2 input.

Symbol	LED On	LED Flashing	LED Off
	The AC source is present and AC input is qualified. The XW Inverter/Charger is ready to charge batteries and pass power through to the loads.	AC input is present, within nominal range and is being qualified.	AC input is not present, or AC input is present but not within nominal range.

When one AC input LED is on and the other AC input LED is flashing, AC input is present on both AC1 and AC2. However, the XW Inverter/Charger can qualify and receive AC input from only one source at a time. The qualified source is represented by the steadily lit LED. When two sources of AC input are present, the XW Inverter/Charger uses the source selected under AC Priority on the System Control Panel AC Settings menu.

### Monitoring Inverter Status

The green kW LED indicates the XW Inverter/Charger is inverting DC input to AC output. When this LED is on or flashing, the display screen shows inverter output power in kilowatts.

Symbol	LED On	LED Flashing	LED Off
	The XW Inverter/Charger is inverting and producing power for connected loads.	The XW Inverter/Charger is selling power to the grid.	The XW Inverter/Charger is not inverting.

### Monitoring Charger Status

The green A LED indicates the XW Inverter/Charger is charging the battery bank. When this LED is on, the display screen shows battery charging current in amps.

**Note:** When a charge cycle ends or charging is manually disabled, the XW Inverter/Charger does not leave charge mode immediately, and the charging LED remains on for 60 seconds.

Symbol	LED On	LED Off
	The XW Inverter/Charger is charging the batteries.	The XW Inverter/Charger is not charging.

## Monitoring Faults and Warnings

The red Fault/Warning LED indicates the presence of a fault or warning in the system. To clear active faults, press the On/Off button momentarily.

Symbol	LED On	LED Flashing
	The XW Inverter/Charger has a fault and has stopped charging or inverting. The LED also turns on steadily if the unit has both a fault and a warning.	The XW Inverter/Charger has a warning. A warning may escalate to a fault if the warning condition does not go away.

## Equalizing Batteries

Button

Pressing the Equalize button (indicated by the  symbol) for five seconds turns battery equalization on and off. After this button is pressed, the XW Inverter/Charger begins the equalization charge after the next charge cycle is complete. Equalization functions only if AC is present and qualified and the charger is enabled. Otherwise the inverter/charger generates a “cannot equalize” fault (W96).



### CAUTION: Battery damage

If improperly performed, equalization can damage your battery. Consult your battery supplier for details on equalizing the battery type in your system.

**Important:** In a system where more than one device is capable of equalizing batteries (such as a system including multiple XW Inverter/Chargers and Solar Charge Controllers), there is no system-wide equalization command for all devices. To equalize with multiple devices, each would have to be enabled individually. Alternatively, equalization can be performed using only one device. During the equalization process, one device applies the equalization charge while the other devices continue to operate in synchronized charge mode, typically in float (three-stage charging) or no-float (two-stage charging).

For more information, see “Equalize Charging the Batteries” on page 3–12.

LED

The yellow Equalize LED indicates that the XW Inverter/Charger is equalizing batteries.

Symbol	LED On	LED Flashing
	The XW Inverter/Charger has begun equalizing the batteries.	Equalization has been enabled but has not begun. The XW Inverter/Charger must complete a charge cycle before applying the equalization charge.



---

## Turning the XW Inverter/Charger On and Off

On/Off control	<p>When the XW Inverter/Charger is operating, pressing and holding the On/Off button (⏻) for five seconds turns the unit off. To return the XW Inverter/Charger to its previous operating state, press the On/Off button momentarily.</p> <p>When the XW Inverter/Charger is being turned off, the other Inverter Information Panel buttons stop working. The shutdown process cannot be cancelled. The XW Inverter/Charger can only be turned back on once the display is blank.</p>
Standby mode	<p>In Standby mode, the XW Inverter/Charger stops charging, inverting, and passing through AC input. However, the unit remains powered up and present on the Xanbus network.</p> <p>To put the XW Inverter/Charger into Standby mode, press and hold the On/Off button and the Equalize button simultaneously for about five seconds. The display shows “Stb.” To return the XW Inverter/Charger to operating mode, press the On/Off button momentarily.</p> <p>Pressing the On/Off button momentarily while the XW Inverter/Charger is operating clears active faults and warnings.</p>
Single-unit installations	<p>In a single-unit installation, when the XW Inverter/Charger is turned off using the On/Off button, Xanbus network power is lost. When Xanbus network power is lost, network-connected accessories such as the Automatic Generator Start (XW-AGS) and XW System Control Panel lose power and stop operating. XW Charge Controllers continue to operate and communicate between each other if Xanbus network power is removed.</p>
Multiple-unit installations	<p>If the On/Off power button is pressed and held on a master XW Inverter/Charger (see “Inverter Mode” on the “Multi-Unit Config Menu” on page 3–23) and an XW-AGS is installed in the system, the unit stops inverting or charging immediately and turns off completely in 120 seconds. During this time, the display shows “OFF.” This interval allows the XW-AGS to stop the generator after a “cool down” period. During the 120-second shutdown time all network communication is blocked and the unit sends a shutdown command to all other devices in the system. As well, the Inverter Information Panel buttons stop working and the shutdown process cannot be cancelled. The XW Inverter/Charger can only be turned back on once the display is blank.</p> <p>In a multiple-unit installation, when a slave XW Inverter/Charger is turned off, other XW Inverter/Chargers continue to supply Xanbus network power and the XW-AGS and XW System Control Panel continue operating.</p>

## Monitoring Battery Level

The row of five LEDs indicates the approximate available capacity of the batteries connected to the system. The capacity reading is based on current-compensated battery voltage.

There are four battery states: empty, low, medium, and full. When the available battery capacity is empty, no LEDs are lit. The battery is considered empty when its depth of discharge exceeds approximately 50 per cent. When the battery capacity is low, the leftmost two LEDs are lit. When the battery is at medium capacity, the leftmost four LEDs are lit. When the battery capacity is full, all five LEDs are lit.

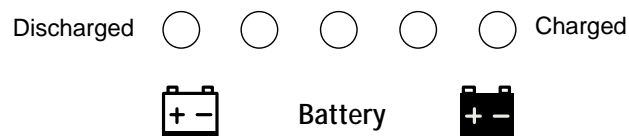

Figure 2-2 Battery Level LEDs

## Reading the Display Screen

The three-character display screen shows the following information about the operating state of the XW Inverter/Charger:

- Output power in kilowatts when the XW Inverter/Charger is inverting and the kW LED is lit.
- Battery charger current when the XW Inverter/Charger is charging and the A LED is lit.
- “Stb” when the XW Inverter/Charger is in Standby mode.
- “Sch” when the XW Inverter/Charger is in Search mode. See “Using Search Mode” on page 3–8.
- “OFF” when the on/off button is pressed and held for five seconds. “OFF” is displayed briefly before the unit turns off.
- “— — —” briefly when the XW Inverter/Charger is in transition between modes, for example, qualifying AC input. The display also shows “— — —” when the XW Inverter/Charger has been manually disconnected from renewable energy power sources and is operating in bypass mode.
- “En” momentarily when the inverter is enabled.
- “dIS” momentarily when the inverter is disabled.

## Monitoring Operation with the XW System Control Panel

The XW System Control Panel provides remote configuration and monitoring capability for the XW Inverter/Charger and other Xanbus-enabled devices in the power system.

You can monitor XW Inverter/Charger operation on the System Control Panel using the:

- System Status screen (see page 2–11)
- XW Inverter/Charger Home screen (see page 2–11)
- XW Inverter/Charger Meters Menu (see page 2–13).

### XW System Control Panel Features

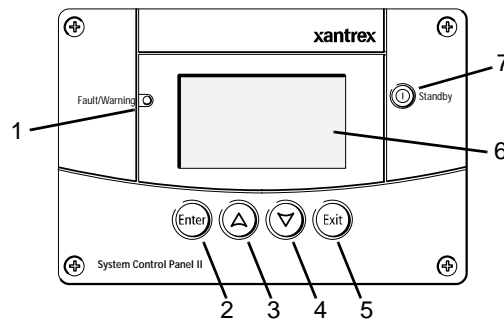

Feature	Description
1	<b>Fault/Warning light</b> indicates a device has a fault or warning condition and requires attention. The light flashes when a warning occurs, and turns on steadily when a fault occurs.
2	<b>Enter button</b> confirms selection of a menu item or displays the next screen.
3	<b>Up arrow button</b> scrolls upwards through screen text or increases a selected value.
4	<b>Down arrow button</b> scrolls downwards through screen text or decreases a selected value.
5	<b>Exit button</b> cancels selection of a menu item or displays the previous screen.
6	<b>Screen</b> shows menus, settings, and system information.
7	<b>Standby button</b> disables inverting and charging on all XW Inverter/Chargers in the system when pressed for one to two seconds. To enable inverting and charging, press the Standby button again.

## Using the Standby Button

The Standby button has two functions, depending on how it is pressed. The Standby button can disable inverting and charging for all XW Inverter/Chargers in the system, or, when pressed simultaneously with the Exit button, put the entire system into Standby mode.

Pressing the Standby button produces the same result as disabling “Invert” and “AC Charge” from the System Settings menu on the System Control Panel. Pressing the Standby button momentarily affects only XW Inverter/Chargers; it does not affect Charge Controller operation. After disabling inverting and charging with the Standby button, the system continues to pass AC input through to the loads, and “— —” is displayed on the Inverter Information Panel.

Pressing the Exit and Standby buttons at the same time puts the entire XW power system (including Charge Controllers) into Standby mode. In Standby mode, the XW Inverter/Chargers stop passing AC input through to the loads, and “Stb” is displayed on Inverter Information Panel.

After the keypress command to enter Standby mode, the XW-AGS (if installed) shuts down the generator (if it is running) after a cool-down cycle.

## System Control Panel Navigation

This section describes the different types of screens and menus on the System Control Panel. To monitor XW Inverter/Charger operation, it is helpful to know how to locate these screens and menus.

### Viewing the System Control Panel Home Screens

The top level screens on the System Control Panel are the Startup screen, the System Status screen and the Device Home screens. After power is applied and the Startup screen appears, the System Control Panel displays the System Status screen. You can view the Device Home screens for the XW Inverter/Charger and other devices in the system by pressing the up and down arrows, as shown in Figure 2-3.

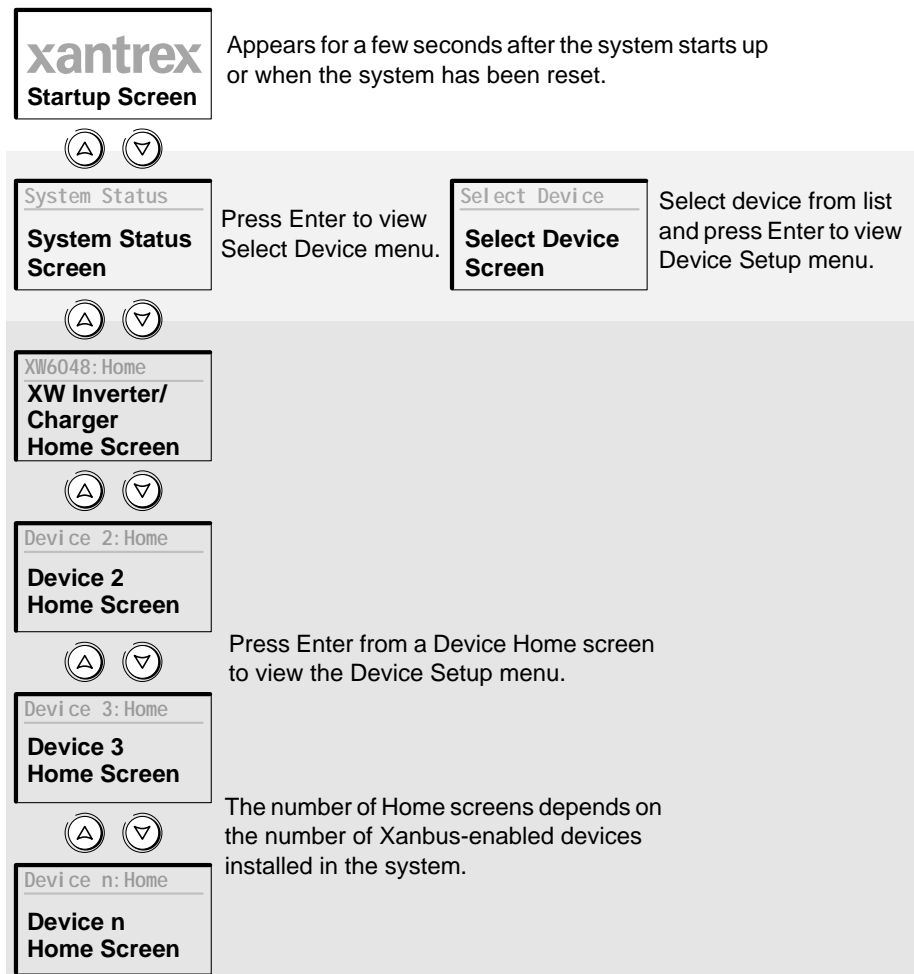

Figure 2-3 System Control Panel Top Level Screens

**System Status Screen** The System Status screen appears after the Startup screen. The System Status screen displays aggregated status information for the entire power system. For example, a single system may have three Xanbus™ network-connected XW Inverter/Chargers, two XW Solar Charge Controllers, one XW-Automatic Generator Start module and one XW System Control Panel all connected to a single battery bank, a single generator, and a common utility grid. The System Status screen always features a “Menu” arrow pointing to the Enter button. Pressing Enter takes you to the Select Device menu. For more information, see “Reading the System Status Screen” on page 2–11.

---

**Important:** If you are uncertain which System Control Panel screen or menu you are viewing, you can always return to the starting point—the System Status screen—by pressing Exit repeatedly until the screens stop changing.

---

**XW Inverter/Charger Home Screen** The XW Inverter/Charger Home screen is the first of the Device Home screens. Each XW Inverter/Charger installed in the system has its own Home screen.

The XW Inverter/Charger Home screen displays status information for the XW Inverter/Charger. The screen appearance varies with the status of the inverter/charger (Standby, Inverting, Charging, AC Bypass, Search, or Equalize). For more information, see “Reading the XW Inverter/Charger Home Screen” on page 2–11.

**To display the XW Inverter/Charger Home screen:**

- ◆ While viewing the System Status screen, press the down arrow key.

**Viewing Other Screens**

This section describes the next level of screens and menus on the System Control Panel.

**Select Device Menu** The Select Device menu displays a list of Xanbus-enabled devices in the system, including the XW Inverter/Charger and the System Control Panel. The Select Device menu is where you can access the Setup menus for each device in the system. The length of the Select Device menu depends on how many Xanbus-enabled devices are installed.

The Select Device menu also contains the Clock menu (where the time and date are set) and the System Settings menu (where system-level settings can be configured). The System Settings, SCP, and Clock menus are always available from the Select Device menu, regardless of the number of Xanbus-enabled devices installed.

**To display the Select Device menu:**

- ◆ While viewing the System Status screen, press Enter.

**Device Setup Menus** Device Setup menus display status information (on the Meters screen) and changeable settings. Changeable settings are identified by the square brackets [ ] around values in the right-hand column.

**To display the Setup menu for a device:**

- ◆ Highlight the device name on the Select Device menu and press Enter.

-Or-

From the Device Home screen, press Enter.

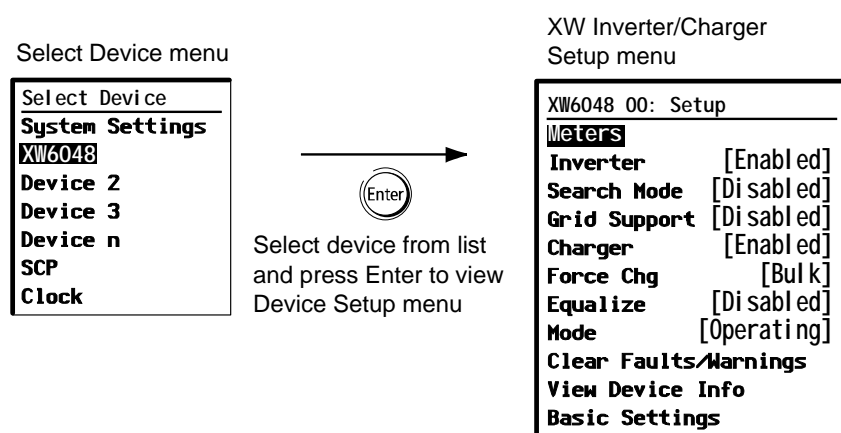

Figure 2-4 Selecting a Device Setup Menu

## Reading the System Status Screen

The System Status screen displays:

- Qualified AC source (if applicable) and total power to and from the source
- Battery voltage and capacity level
- Net battery input or output current
- Total inverter loading
- Time and date.

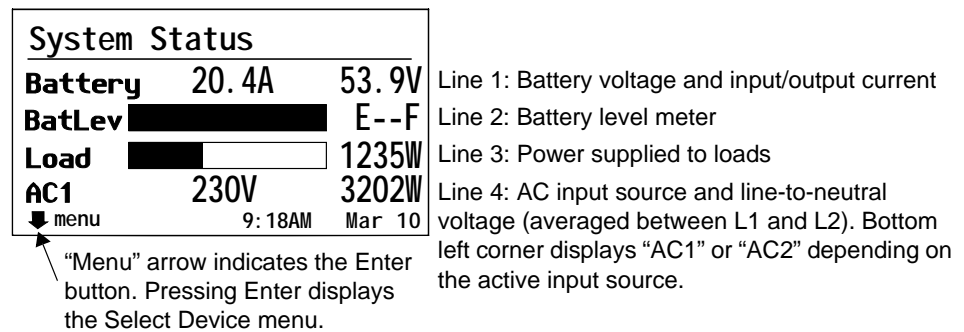

Figure 2-5 System Status Screen

## Reading the XW Inverter/Charger Home Screen

The XW Inverter/Charger Home screen displays real-time operating data specific to the XW Inverter/Charger. The XW Inverter/Charger status changes according to the states described in Table 2-1 on page 2–12.

**To view the XW Inverter/Charger Home screen:**

- ◆ On the System Home screen, press the down arrow button until the XW Inverter/Charger Home screen appears.

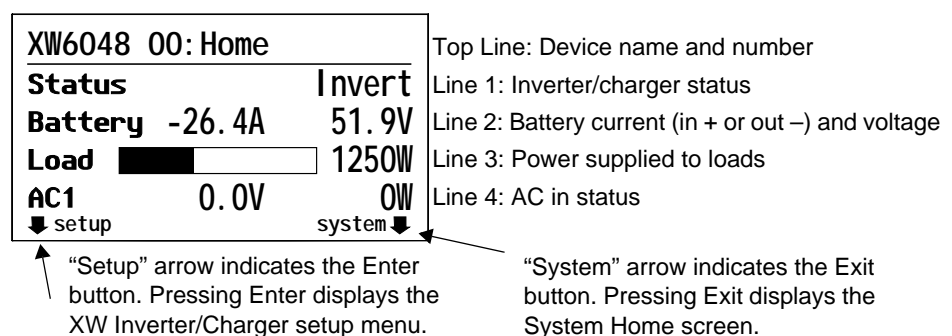

Figure 2-6 XW Inverter/Charger Home Screen

Pressing the down arrow button from the XW Inverter/Charger Home screen displays the Home screens for other XW Inverter/Chargers and other Xanbus-enabled devices in the system.

Table 2-1 XW Inverter/Charger Home Screen States

XW Inverter/Charger Status	Displayed When...
Invert	The XW Inverter/Charger is supplying power to loads by inverting power from the batteries. AC input from the utility or generator is absent or out of nominal range.
Qualifying AC	The XW Inverter/Charger is determining if AC input is within a usable voltage and frequency range. “Qualifying AC” is also displayed when the XW Inverter/Charger is awaiting application of AC power or a command to enable invert mode.
Charging	The XW Inverter/Charger is charging the batteries from qualified AC input from the utility grid or a generator. The charge state is in transition to either Bulk, Absorption, Float or Equalize. AC input is also passed through to the load while charging.
Bulk	The XW Inverter/Charger is bulk charging the batteries from qualified AC input from the utility grid or a generator. AC input is also passed through to the load while bulk charging.
Absorption	The XW Inverter/Charger is absorption charging the batteries from qualified AC input from the utility grid or a generator. AC input is also passed through to the load while absorption charging.
ABS Finish	The XW Inverter/Charger has completed the absorption stage and is waiting for other chargers in the system to complete absorption. This status can occur only when there is another device (an inverter/charger or charge controller) also charging the battery.
Float	The XW Inverter/Charger is float charging the batteries from qualified AC input from the utility grid or a generator. The XW Inverter/Charger is set for three-stage charging. AC input is also passed through to the load while float charging.
CHG Finish	The XW Inverter/Charger has completed charging or the charge cycle has been interrupted and is transitioning to the next state. This stage last about one minute, while the battery is allowed to settle. The delay keeps the inverter/charger from unnecessarily transitioning to Grid Support (if enabled) after a charge cycle.
Fault	The XW Inverter/Charger has an active fault. The Fault/Warning light on the System Control Panel is on.
Gen Support	<p>There is AC input from the generator, and the XW Inverter/Charger is supporting the generator by supplying additional power to the critical loads.</p> <p>The XW Inverter/Charger supports the generator (or other power source connected to the AC2 input) when the AC load current drawn from AC2 exceeds the GenSup Amps setting for 1 to 2 seconds.</p> <p>The XW Inverter/Charger uses stored DC capacity to load share with the generator until the total AC load current (generator plus inverter output) drops by 2 amps plus 10 per cent of the GenSup Amps setting for 6 seconds.</p> <p>For example, if GenSup Amps is set to 10 amps, the inverter starts to support when the load exceeds 10 amps for 2 seconds and stops when it drops more than 3 amps below the GenSup Amps setting, or 7 amps (2 amps plus 10 per cent of 10 amps = 3 amps).</p> <p>The system can enter this state if the battery voltage is above the Low Batt Cut Out setting and Gen Support is enabled. See “Generator Support Settings” on page 3–20.</p>



Table 2-1 XW Inverter/Charger Home Screen States

XW Inverter/ Charger Status	Displayed When...
Grid Support	<p>There is AC input from the utility and the XW Inverter/Charger is supporting the utility grid by supplying additional power to the critical loads.</p> <p>The XW Inverter/Charger supports the utility grid by limiting the power drawn from the utility to less than 10 per cent of the load demand. This mode is desirable for using excess energy from auxiliary DC sources like PV, while still maintaining a charged battery bank. No power is sold to the utility in this mode.</p> <p>The XW Inverter/Charger enters this state only when the Grid Support is set to “On” and battery voltage is above the Grid Supp Volts setting. See “Grid Support Settings” on page 3–16.</p>
Load Shaving	<p>There is AC input from the utility, and the XW Inverter/Charger is supporting the utility grid when the current required to power the loads rises above the Load Shave Amps setting between the Load Shave Start and Load Shave Stop times set on the Grid Support menu.</p> <p>Many utilities impose a surcharge on their customers based on the peak load used by a facility. When load shaving, the XW Inverter/Charger uses stored DC capacity to reduce the peak load on the utility grid and keep current draw from the grid equal to or under the Load Shave Amps setting. The XW Inverter/Charger enters this state only when Grid Support is enabled, the Load Shave time window is valid and the load draw exceeds the Load Shave Amps setting. See “Grid Support Settings” on page 3–16.</p>
Search	<p>Search Mode is enabled and the XW Inverter/Charger is standing by, waiting to begin inverting. See “Using Search Mode” on page 3–8.</p>
SellToGrid	<p>The XW Inverter/Charger is grid tied and selling power to the utility grid. Both Grid Support and Sell must be enabled in order to sell power back to the utility. See Table 3-1 on page 3–2 and “Grid Support Settings” on page 3–16. All configurations must comply with local and national electrical codes.</p>
Standby	<p>The unit has been placed in Standby mode using the “Mode” setting on the SCP Setup menu or the Standby button on the SCP or using the Standby key press (On/Off and Equalization) on the Inverter Information Panel.</p>
Passthru	<p>The AC connected to the AC1 or AC2 input is passing directly through the XW Inverter/Charger to the loads. The batteries are not being charged in this state.</p>
Equalize	<p>Equalization has been turned on and the XW Inverter/Charger is equalizing the batteries after completing a full charge cycle.</p>

## Reading the Meters Screen

The Meters screen displays total system power production, grid voltage and current status, and load voltage and current status.

### To view the Meters screen:

- ◆ On the XW Inverter/Charger setup menu, highlight “Meters” and press Enter.

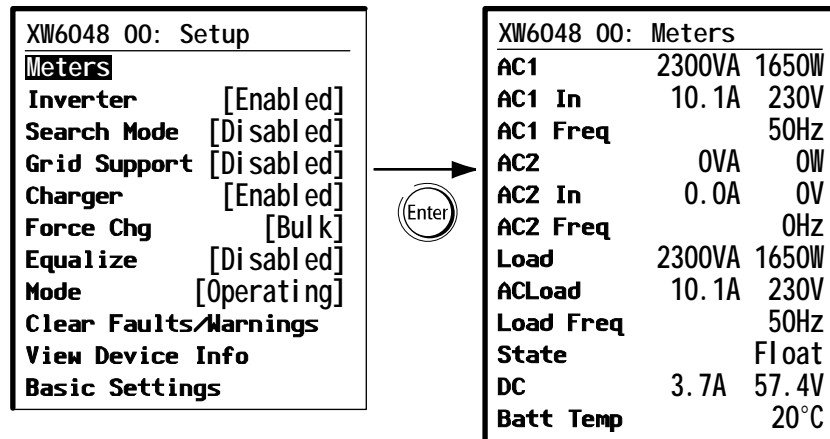

Figure 2-7 Viewing the Meters Screen

Table 2-2 Meters Screen

Screen Item	Description
AC1	AC input power connected to the XW Inverter/Charger AC1 terminals, in Volt-Amps and Watts. AC1 is assumed to be connected to the utility grid, but can be connected to any other AC source.
AC1 In	AC input voltage and current connected to the XW Inverter/Charger AC1 terminals. This input voltage display may drift slightly before the inverter has synchronized to the grid.
AC1 Freq	AC frequency connected to the XW Inverter/Charger AC1 terminals.
AC2	AC input power connected to the XW Inverter/Charger AC2 terminals, in Volt-Amps and Watts. AC2 is assumed to be connected to a generator, but can be connected to any other AC source.
AC2 In	AC input voltage and current supplied to the inverter/charger from the AC2 input. This meter indicates the inverter/charger is drawing power from the generator to charge the battery or power the AC loads.
AC2 Freq	AC frequency connected to the XW Inverter/Charger AC2 terminals.
Load	Power consumed by the AC loads, in Volt-Amps and Watts.
ACLoad	AC voltage and current supplied to the AC loads.
Load Freq	AC frequency supplied to the AC loads.
State	Operating state of the XW Inverter/Charger. For more information, see Table 2-1 on page 2–12.
DC	Charging current and battery voltage.
Batt Temp	Battery Temperature, as read by the BTS connected to this XW Inverter/Charger. If the BTS is not installed, Batt Temp reads “NotAvailable.”

# 3

## Configuration

Chapter 3, “Configuration” explains how to navigate through the XW System Control Panel menus and configure the XW Hybrid Inverter/Charger.

Topics in this chapter include:

- “Using the XW System Control Panel” on page 3–2
- “Using the Setup Menus” on page 3–4

## Using the XW System Control Panel

The XW Inverter/Charger is configured using the XW System Control Panel. The System Control Panel provides access to settings relating to AC input and output, battery charging, and grid-tie operation.

### XW Inverter/Charger Setup Menu

The XW Inverter/Charger Setup menu is accessible either from the System Home screen or from the XW Inverter/Charger Home screen.

**To navigate to the XW Inverter/Charger Setup menu:**

1. From the System Home screen, press Enter to view the Select Device menu. Go to step 2.

Or

From the XW Inverter/Charger Home screen, press Enter. The XW Inverter/Charger Setup menu appears.

2. Highlight the XW Inverter/Charger device name, and press Enter.

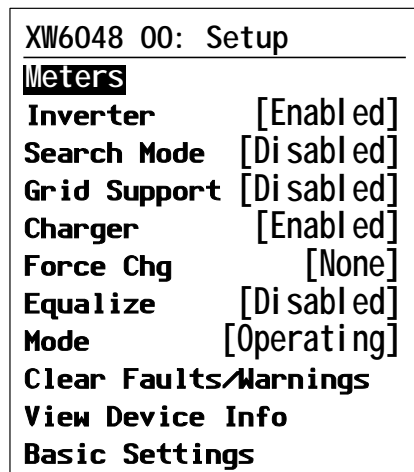

Note: The System Control Panel displays only four lines of the Setup menu at one time. To view additional settings, press the Down arrow button.

Figure 3-1 XW Inverter/Charger Setup menu

Table 3-1 XW Inverter/Charger Setup menu

Menu Item	Description
Meters	Displays the Meters screen.
Inverter	Enables or disables the inverter.
Search Mode	Turns Search Mode on and off. See “Using Search Mode” on page 3–8.
Grid Support	Enables or disables grid-interactive inverter/charger features, such as Grid Support and Grid Sell mode. See “Grid Support Settings” on page 3–16. To allow Grid Support to function after battery charging has completed, it is recommended to set the Charge Cycle to 2-Stage. See “Charger Settings Menu” on page 3–9.
Charger	Enables or disables the charger.

**Table 3-1** XW Inverter/Charger Setup menu

Menu Item	Description
Force Chg	Manually changes the charge stage to either Bulk or Float (when 3-Stage cycle is selected) or Bulk or NoFloat (when 2-Stage cycle is selected).
Equalize	Enables or disables battery equalization.
Mode	Selects the XW Inverter/Charger operating mode: Operating or Standby. The red Standby button on the System Control Panel has similar functionality (see “XW System Control Panel Features” on page 2–7).
Clear Faults/Warnings	Clears any active faults or warnings. If the fault or warning condition is still present, the fault or warning message may reappear.
View Device Info	Displays the Device Info screen. On the Device Info screen you can view the Warning Log, Fault Log and Event Log.
Basic Settings	Select to display and/or adjust the basic XW Inverter/Charger settings. See “Using the Setup Menus” on page 3–4.

## Setting the Time and Date

The system time and date are set using the System Control Panel. XW Inverter/Charger advanced features such as peak load shaving, Charger Block, and time-stamped events (faults and warnings and logged historical data) require that the system be set to the correct time.

The System Control Panel has an internal clock that controls the time for all Xanbus-enabled devices in the system. You can set the time, time format, and date on the Clock menu. The Clock menu is accessible on the Select Device menu.

For more information, see “Setting the Time” and “Setting the Date” in the *XW System Control Panel Owner’s Guide*.

If a Xantrex Communications Gateway is connected to the system, the Gateway controls the time and date for the entire system, including the XW Inverter/Charger. For more information, see the *Communications Gateway Installation Guide*.

---

## Using the Setup Menus

Basic menu	The XW Inverter/Charger configuration settings can be viewed in Basic and Advanced formats (see Figure 3-3, “Basic and Advanced Settings” on page 3–6). The Basic settings include configuration items you may have to adjust routinely, or as part of initial setup.
Advanced menu	The Advanced settings option gives you access to the full range of XW Inverter/Charger settings, including everything displayed on the Basic menu. As a safeguard against unintended Advanced configuration, the System Control Panel displays the Basic settings by default. To view the Advanced settings, you must perform a special keypress.



### **WARNING: Risk of fire and shock hazard**

The Advanced settings are intended for qualified installation/service personnel only. Before changing Advanced settings, you must be familiar with the settings and the system-wide impact of changing those settings. Setting parameters incorrectly could damage connected equipment (such as batteries) or could severely affect the performance of your system. Incorrect charging configuration can lead to battery damage and risk of fire. Consult the local utility before enabling sell mode or changing grid support settings. All configurations must comply with local and national electrical codes.

---

#### **To select the Advanced settings:**

1. On the Select Device menu, select an XW Inverter/Charger.
2. Press Enter + up arrow + down arrow at the same time.

---

#### **Notes:**

- This keypress enables the Advanced settings for every device in the system.
- After performing the keypress, “Advanced Settings” appears at the top of the Setup menu. When the keypress is performed again, the Setup menu displays “Basic Settings” as the last item on the menu.

---

The XW Inverter/Charger Advanced settings include menus for configuring:

- Inverter settings (see page 3–7)
- Charger settings (see page 3–9)
- AC transfer limit settings (see page 3–15)
- Grid Support and Peak Load Shaving settings (see page 3–16)
- Generator Support settings (see page 3–20)
- Auxiliary output settings (see page 3–21).
- Multi-Unit Operation, including customizing the default model name of the inverter/charger, and setting its network device number. Setting the device number is important when multiple XW Inverter/Chargers are on the Xanbus network and sharing connections such as AC loads, utility grid, and generator. The device number is also used when configuring paralleled XW Inverter/Chargers for master-slave operation (see page 3–7).

In the Advanced settings you can also copy another unit’s settings using the “Copy from” command.

**To view the Advanced or Basic settings:**

- ◆ From the Setup menu, with Basic Settings or Advanced Settings highlighted, press Enter. See Figure 3-2.

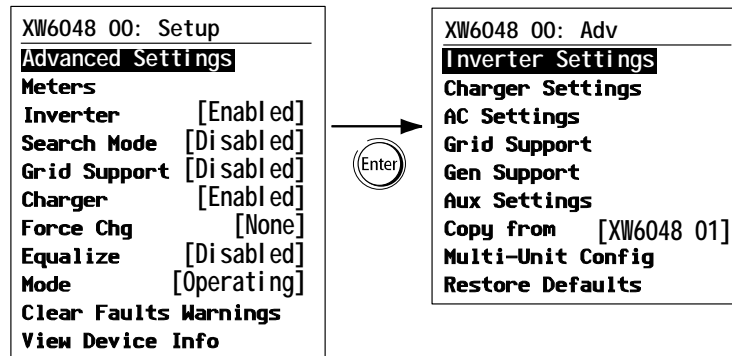

Figure 3-2 Selecting Advanced Settings

**To select and change a configurable setting:**

1. On the desired configuration menu, press the up arrow or down arrow button to highlight the setting you want to change.
2. Press Enter to highlight the current value of the setting.
3. Press the up arrow or the down arrow button to change the value. Hold down the button to scroll through a large range of values quickly.  
The previously set value appears with an asterisk (\*) beside it.
4. Press Enter to select the value.
5. If you have another setting to change, return to step 1.

Or

If you have no more settings to change, press Exit until the System Control Panel displays the desired screen or menu.

---

**Important:** If you have no more settings to change, it is recommended to leave the Setup menu in the Basic Settings format to help prevent unintended configuration. If the Setup menu displays “Advanced Settings,” press Enter + up arrow + down arrow at the same time. The Setup menu should then display “Basic Settings” as the last item on the menu.

---

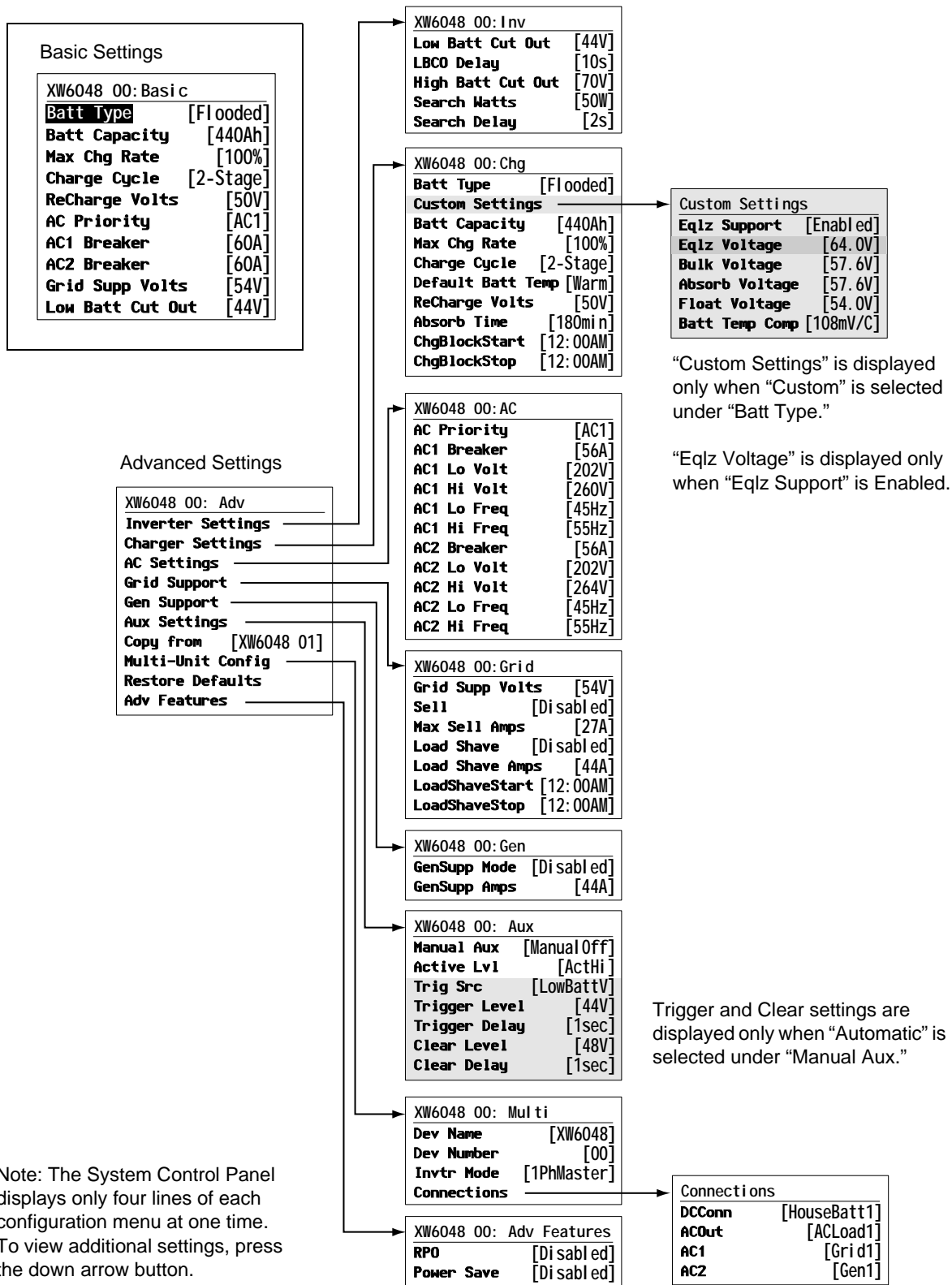

Figure 3-3 Basic and Advanced Settings



## Inverter Settings Menu

The Inverter Settings Menu contains settings that control when the XW Inverter/Charger turns on and off while inverting.

**Table 3-2** Inverter Settings menu

Item	Description
Low Batt Cut Out	This setting controls when the inverter turns off due to a low battery voltage condition. The inverter will turn off only after this level has been reached for the period of time set by the LBCO Delay. This setting is not temperature compensated.
LBCO Delay	LBCO Delay controls how long the inverter is allowed to operate at or below the Low Battery Cut Out level before turning off due to a low battery voltage condition. The inverter will turn off only after the Low Batt Cut Out level has been reached for this uninterrupted period of time. Once the inverter has shut off, the battery voltage must rise 2 volts above the Low Batt Cut Out setting (1 volt for 24 V systems) for inverter operation to resume.
High Batt Cut Out	High Batt Cut Out sets the maximum battery voltage at which the inverter will operate. If the battery voltage exceeds this limit for more than 1 minute, the inverter displays a fault message (F49) and shuts down. The inverter will not support AC loads when in this condition. If a qualified AC source is present, the unit passes AC through to the loads. The inverter automatically restarts when the voltage drops to 3 volts (24-volt system) or 6 volts (48-volt system) below the High Batt Cut Out setting. If battery voltage continues to rise after shutdown, an external charger may still be charging the batteries. The XW Inverter/Charger cannot control how external chargers operate.
Search Watts	Search Watts sets the inverter's search sensitivity when Search mode is enabled. When a load larger than this setting is present, the inverter turns on. Enabling Search mode from the Setup Menu (see page 3-2) can minimize power draw from the battery during periods of low demand from loads. Also see "Using Search Mode" on page 3-8.
Search Delay	Search Delay sets the time between search pulses. When searching for loads, the XW Inverter/Charger sends out search pulses to determine if a load is present. If the XW Inverter/Charger finds a load above the Search Watts setting, the inverter comes on. XW Inverter/Charger power draw while in Search mode decreases when Search Delay is increased, but the inverter's response time to active loads is reduced.

For default settings, see "Inverter Menu" on page B-3.

### Using the Low Battery Cut Out and LBCO Delay Settings

The Low Batt Cut Out setting is the lowest battery voltage level acceptable for use by the inverter. When the batteries discharge to the Low Batt Cut Out setting, and are held at or below this level for the LBCO Delay time, the inverter output shuts down and transfers any available AC source (generator or grid) to the charger to bring the battery level back above the Low Batt Cut Out setting. After shutdown, the inverter does not support any AC loads, and AC loads must be powered by either a generator or grid power.

If using an automatic generator starting system, it is recommended to set the AGS voltage trigger setting higher than the XW Inverter/Charger Low Batt Cut Out voltage. Otherwise, inverter output turns off before the generator automatically starts, causing the battery voltage to recover slightly. This may then stop the AGS from starting the generator or result in the inverter cycling on and off multiple times before the generator automatically starts.

If using an automatic generator starting system with the start trigger set to the same voltage as the LBCO voltage, do not set the LBCO Delay for less than the amount of time it takes the generator to start and connect. Otherwise, inverter output turns off before the generator automatically starts, causing the battery voltage to recover slightly. This may then stop the AGS from starting the generator or result in the inverter cycling on and off multiple times before the generator automatically starts.

## Using Search Mode

Why use Search mode?	<p>Search mode allows the inverter to selectively power only items that draw more than a certain amount of power, which can result in power savings.</p> <p>The XW Inverter/Charger has a no-load power draw of about 28 watts. Enabling Search mode reduces this power draw to less than 8 watts.</p> <p>Search mode operates differently in single-unit and multi-unit installations.</p>
Single units	<p>When a single XW Inverter/Charger has Search mode enabled, the inverter sends electrical search pulses through its AC output. These search pulses “look” for connected AC loads. The delay between search pulses is set using the Search Delay setting.</p> <p>After a load larger than the Search Watts setting is detected, the inverter turns on.</p>
Multiple units	<p>To use Search mode in multiple-unit installations with paralleled XW Inverter/Chargers, the master unit must have Search mode disabled. Slave units must have Search mode enabled.</p> <p>When Search mode is disabled on the master unit and Search mode is enabled on slave units, only the master XW Inverter/Charger operates, and the slave units come on-line only when the load exceeds approximately 60 per cent of the rated output of the master unit. In a three-unit system, the third slave unit turns on if the load on the master does not drop below 60 per cent about 3 to 5 seconds after a slave unit turns on to assist the master. When the load drops below 20 per cent of the master’s rated output, the slave units turn off in reverse order; that is, the last slave unit to turn on is the first to turn off.</p>
When to set up Search mode	<p>The Search mode feature is only valuable if the inverter can spend a fair amount of time “sleeping” each day. Therefore, if Search mode is to be utilized it must be adjusted properly. The initial adjustment should be made so that the inverter comes on only when needed.</p> <p>Certain types of loads can cause Search mode not to work as expected. These types of loads are described on page 4–3 of the Troubleshooting chapter. If these kinds of loads are in the system, follow the suggestions given to eliminate the problem.</p>

If the problem loads cannot be eliminated, there are two work-around solutions:

1. Disable Search Mode from the main XW Inverter/Charger Setup menu, causing the inverter to always remain at full output voltage.
2. Use a search-friendly “companion load” whose only purpose is to be switched on to “wake up” the inverter to power the load that is unable to bring the inverter out of Search mode.

---

**Notes:**

- Search mode, by function, cannot work with clocks and timers or devices that need power 24 hours a day. Examples of devices with timers include video recorders, coffee makers with brew timers, refrigerators, and freezers with defrost timers. Examples of devices that need power 24 hours a day include telephone answering machines, alarm systems, motion detection lights, and some thermostats.
  - When the inverter is searching the output for loads, lights that have a wattage lower than this setting may flash momentarily.
- 

## Charger Settings Menu

The Charger Settings menu gives you options for configuring the XW Inverter/Charger to operate from your battery bank.

**Table 3-3** Charger menu items

Item	Description
Batt Type	Batt Type selects the system battery chemistry and type: Flooded (default), AGM, Gel and Custom. Selecting Custom displays the Custom Settings item, which allows you to adjust the settings for each charging stage.
Custom Settings	Displays the Custom Battery Settings menu, where you can adjust settings specific to your battery type and installation. The Custom Settings item is displayed only after “Custom” is selected under Batt Type.
Batt Capacity	Selects the system battery capacity in amp-hours.
Max Chg Rate	Sets the percentage of the maximum DC output current that is available to the charger. The maximum DC output current for different models is: <ul style="list-style-type: none"> <li>• XW4024—150 Adc</li> <li>• XW4548—85 Adc</li> <li>• XW6048—100 Adc.</li> </ul>
Charge Cycle	Sets the charging method: 3-Stage (Bulk, Absorption, Float) and 2-Stage (Bulk, Absorption, NoFloat).
Default Batt Temp	Selects the battery temperature charging compensation if a battery temperature sensor is not installed. In the absence of a battery temperature sensor, the charger uses one of three settings: “Cool” (5 °C), “Warm” (25 °C), or “Hot” (40 °C).
ReCharge Volts	Sets the battery voltage level at which a new charge cycle begins.
Absorb Time	Sets the time spent in the Absorption stage, before transitioning to Float or NoFloat.

**Table 3-3** Charger menu items

Item	Description
Chg Block Start	Sets the time to halt charging on AC1 (Grid). The AC2 (Gen) port is unaffected by the Charger Block settings. The Charger Block Start and Stop settings allow you to select when the charger stops charging on AC1. To disable the Charger Block function, set Chg Block Start and Chg Block Stop to the same time. See “Using Charger Block” on page 3–13.
Chg Block Stop	Sets the time that charging on AC1 can resume. At the Chg Block Stop time, charging on AC1 is enabled again.

For default settings, see “Charger Menu” on page B–3.

## Battery Charger Functions

Whenever AC is present on the XW Inverter/Charger input, the unit can operate as a battery charger. Different battery types and chemistries require different charging voltage levels. Not charging batteries at the required levels can shorten battery life or damage the batteries. The XW Inverter/Charger is configured at the factory to work with the battery types recommended for inverter applications. If the default settings do not work for your specific installation, you can adjust the charge stage settings (as recommended by the battery manufacturer) on the Custom Battery Settings menu (see page 3–14).

**Note:** This information is provided for guidance only. Variations in battery chemistry and site-specific environmental considerations mean that you should consult your system designer or battery manufacturer for specific recommendations for appropriate battery voltage and current settings.

## Multi-Stage Charging Process

The charging cycle is a multi-stage process. Whenever qualified AC power is present at the inverter’s input, it passes power through to the connected load and begins charging the batteries.

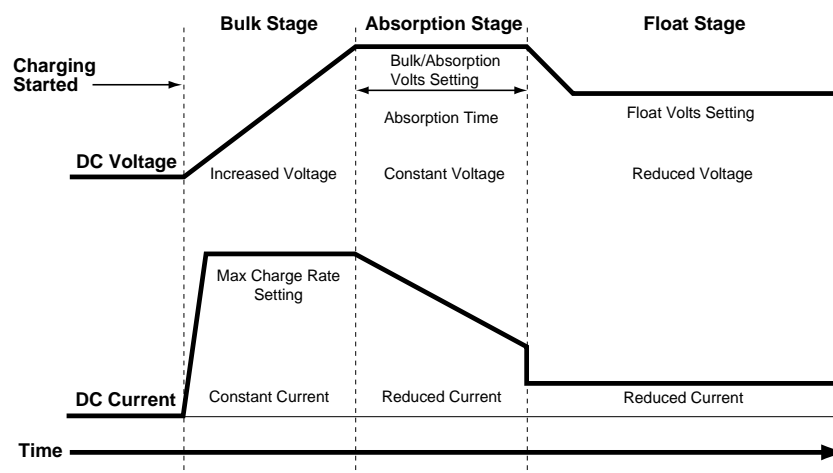

**Figure 3-4** Three-Stage Battery Charging Cycle

---

Bulk Stage	<p>Bulk charge is the first stage in the charging process and provides the batteries with a controlled, constant current. Once the battery voltage rises to the bulk voltage threshold, the charger switches to the Absorption stage.</p>
Absorption Stage	<p>Absorption charge is the second stage of battery charging and provides the batteries a controlled, constant voltage. During this stage, the current supplied to the batteries slowly decreases. When this current falls below 2 per cent of the battery capacity, or when the configurable Absorb Time expires, the charger switches to the Float or NoFloat stage, depending on the selected charge cycle.</p> <hr/> <p><b>Note:</b> If there are DC loads on the batteries, the charger's current may never decrease to a level to initiate the next stage of charging. In this case, the charger would stay in absorption until the Absorb Time setting is reached.</p> <p>To ensure the charger does not remain in absorption for too long, adjust Absorb Time on the Charger Settings menu. The timer begins at the start of the absorption stage and terminates absorption charging if the charge current does not decrease to below 2 per cent of the battery capacity before the Absorb Time setting expires. The Absorb Time setting may be increased if the charge cycle continually runs the full Absorb Time in the absence of DC loads. This is an indication of too large a battery bank for the selected Absorb Time setting.</p> <hr/>
Float Stage	<p>Float charge maintains a trickle charge on the batteries whenever AC is present on the XW Inverter/Charger input. Float charging reduces battery gassing, minimizes watering requirements (for flooded batteries), and ensures the batteries are in a constant state of readiness. When three-stage charging is selected, the charger automatically switches to the float stage after the batteries have received a bulk and absorption charge (see Figure 3-4 on page 3-10). The batteries will be maintained at the default float voltage level for the selected battery type or the voltage selected under Float Voltage on the Custom Battery Settings menu.</p> <hr/> <p><b>Note:</b> The battery voltage can increase above the float voltage when using an external charging device such as PV arrays, wind turbines, and micro-hydro generators. Be sure to include appropriate charge management equipment with all external DC sources.</p> <hr/>
Two-Stage	<p>Two-stage (or No Float) mode differs from an ordinary three-stage charge mode in that it does not continuously maintain the battery at float voltage. Instead, the XW Inverter/Charger begins charging the battery in bulk mode whenever the battery voltage drops below the recharge level. While the battery voltage is above the recharge level the inverter's AC transfer switch continues to pass power through from the utility grid to the loads, but does not actively charge the batteries. Two-stage mode increases efficiency of utility connected systems by reducing the amount of power consumed by the inverter and batteries compared to when the battery is continuously maintained at Float voltage. This feature can extend the life of most batteries.</p> <p>To allow Grid Support and Sell Mode to function after battery charging has completed, it is recommended to set the Charge Cycle to two-stage.</p>

---

**Note:** If the AC input fails or drops below the lower Vac limit (as set in “AC Settings”), the complete multi-stage charge cycle (Bulk, Absorption, Float/No Float) restarts once the source AC returns to an in-tolerance condition. If the batteries are already nearly full, the charge cycle will take little time to complete.

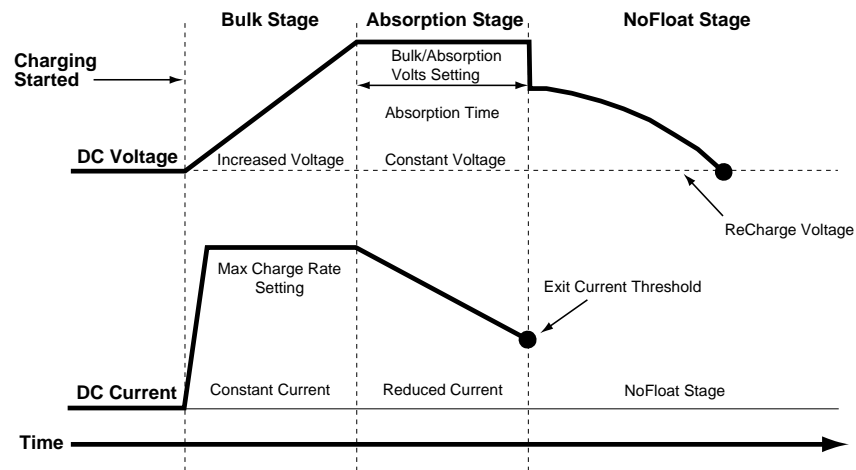

Figure 3-5 Two-Stage Charging Cycle

## Equalize Charging the Batteries

Many battery manufacturers recommend periodic equalize charging to level out the voltage between individual cells, improving battery performance and lifespan.

Over time, the battery’s electrolyte can become “stratified,” causing inactive areas in the plate material. If this condition is allowed to continue for extended periods, the battery plates can “sulfate” and become unusable. Equalizing the batteries is a controlled overcharging method that mixes up the electrolyte and reactivates the unused areas of the plate material, restoring batteries to a full state of charge.

Consult the battery manufacturer’s recommendation for equalize charging settings.

### To start equalizing the batteries:

- ◆ On the XW Setup menu, highlight Equalize and select Enable.

-Or-

Press the equalize button on the Inverter Information Panel for five seconds.



### **WARNING: Explosion hazard**

Only flooded or vented batteries should be equalize charged. Hydrogen and oxygen gases are produced when batteries are equalize charged. Provide adequate ventilation and remove all sources of ignition to prevent explosion.

**Important:** In a system where more than one device is capable of equalizing batteries (such as a system including multiple XW Inverter/Chargers and Solar Charge Controllers), there is no system-wide equalization command for all devices. To equalize with multiple devices, each would have to be enabled individually. Alternatively, equalization can be performed using only one device. During the equalization process, one device applies the equalization charge while the other devices continue to operate in synchronized charge mode, typically in float (three-stage charging) or no-float (two-stage charging).

---

## Using Charger Block

The Charger Block feature halts charging on AC1 (Grid) for a period of time each day. This period of time is defined by the Chg Block Start and Chg Block Stop settings. In areas where the utility charges variable rates for electricity, it is preferable to use utility power for charging only during non-peak hours. Charger Block can prevent utility power from being used for battery charging during peak billing periods.

During the time period set between Chg Block Start and Chg Block Stop, AC1 (Grid) input continues to be passed through to the loads. Inverter operation remains unaffected during the charger block period.

During the Charger Block period, no charging on AC1 occurs even if the batteries discharge below ReCharge Volts setting. However, a generator connected to AC2 (in the absence of utility/AC1 power) or an XW Solar Charge Controller may charge batteries during the Charger Block period. AC priority must be set to AC2 to charge batteries with a generator connected to AC2 during the Charger Block period.

If the charger is operating (that is, in Float, Absorption, Bulk or Equalize stage) at the Chg Block Start time, charging on AC1 stops immediately and the charger enters an idle state identical to No Float (see “Two-Stage” on page 3–11). When the Charger Block period is over, the charger does not resume the charge stage that Chg Block Start interrupted. Instead, if the batteries are above the ReCharge Volts setting, the charger remains idle.

If the battery voltage falls below the ReCharge Volts setting during the Charger Block period, the XW Inverter/Charger begins a new charge cycle with the Bulk stage after the Charger Block period has expired (at the Chg Block Stop time).

For example, Charger Block is set to start at 5:00 PM and end at 8:00 PM. If the XW Inverter/Charger is charging from AC1, charging stops at 5:00. When Charger Block ends at 8:00, the XW Inverter/Charger does not automatically resume charging. The unit first measures the battery voltage. If the voltage is below the ReCharge Volts setting, then the XW Inverter/Charger starts a new charge cycle from Bulk. If the battery voltage is above the ReCharge Volts setting, the XW Inverter/Charger remains idle and continues passing through AC to the loads. The XW Inverter/Charger also keeps measuring the battery voltage as before to determine whether to start a new charge cycle.

## Custom Battery Settings Menu



### CAUTION: Equipment damage

To avoid damaging your batteries during charging or equalization, consult your battery manufacturer and associated documentation before setting a custom battery type.

The Custom Settings menu can be selected after “Custom” is selected under Batt Type.

The Custom Settings menu allows you to adjust charging and equalization voltage for batteries with specifications that fall outside the default settings for the battery types the XW Inverter/Charger offers.

You can also adjust the temperature compensation constant for the Battery Temperature Sensor on the Custom Battery menu.

**Important:** All settings for configuring a custom battery type are based on the default settings for a Flooded battery type.

Table 3-4 describes the options available on the Custom Battery menu.

**Table 3-4** Custom Battery Settings menu items

Item	Description
Eqlz Support	Enables or disables the ability to enter an equalization cycle. Refer to the battery manufacturer’s specifications to determine whether equalization is recommended.
Eqlz Voltage <sup>a</sup>	Selects the equalization voltage. Consult your battery manufacturer for equalization voltage setting.
Bulk Voltage	Sets the bulk voltage for a custom battery type.
Absorb Voltage	Sets the absorption voltage for a custom battery type.
Float Voltage	Sets the float voltage for a custom battery type.
Batt Temp Comp	Battery temperature compensation for a custom battery type. This setting is the reference that the BTS uses to adjust the charging voltage when the temperature is above or below 25 °C (77 °F). The following voltage thresholds are not temperature compensated: <ul style="list-style-type: none"> <li>• Grid Support entry voltage</li> <li>• Grid Support exit voltage</li> <li>• Low Battery Cut-Out trigger voltage</li> <li>• Low Battery Cut-Out condition clear voltage</li> </ul> The following battery voltage setpoints are temperature compensated: <ul style="list-style-type: none"> <li>• Float exit voltage</li> <li>• Bulk exit voltage</li> <li>• Float and Gassing voltages used in Constant Voltage exit criteria</li> <li>• Recharge Volts</li> <li>• Charge Control target voltage</li> </ul>

a. The Eqlz Voltage setting is displayed when Eqlz Support is set to On.

For default settings, see “Custom Battery Menu” on page B-4.



## AC Settings

The AC Settings menu configures the voltage and frequency limits for AC line 1 (grid) and AC line 2 (generator). These are the limits at which the XW Inverter/Charger considers input voltage qualified—that is, suitable for charging batteries or powering loads. If the input voltage is not qualified according to these settings, the XW Inverter/Charger transfers from using AC input to inverting.

**Table 3-5** AC Settings menu

Item	Description
AC Priority	<p>Sets the priority for the AC source (AC1 or AC2) for qualification and transfer. For example, this setting allows the XW Inverter/Charger to use a renewable energy source (such as an AC hydro generator) connected to AC2 on a first-priority basis and use utility power only when renewable energy is insufficient or unavailable to power loads.</p> <p>In systems that use both utility grid (AC1) and generator (AC2) input, AC Priority is recommended to be set to AC2. Assuming the generator is intended for occasional use only, the XW Inverter/Charger will use utility power until the generator is started.</p>
AC1 Breaker	Sets the AC1 (Grid) breaker size, based on the size of the breaker installed on AC1. The installed breaker size must not exceed the capacity of the upstream distribution panel. The XW Inverter/Charger limits the maximum input current to this setting by derating its charging current. If the connected loads exceed the AC1 breaker setting, the AC breaker trips. The breaker may not trip if Grid Support is enabled and battery voltage is above the Grid Support Volts setting, or if Peak Load Shave is enabled and the Load Shave Time window is active.
AC1 Lo Volt	Minimum acceptable input voltage level from the utility grid.
AC1 Hi Volt	Maximum acceptable input voltage level from the utility grid.
AC1 Lo Freq	Minimum acceptable utility grid input frequency.
AC1 Hi Freq	Maximum acceptable utility grid input frequency.
AC2 Breaker	Sets the AC2 (Gen) breaker size, based on the size of the installed AC breaker. The breaker size must not exceed the capacity of the generator. The XW Inverter/Charger limits the maximum input current to this setting by derating its charging current. If the connected loads exceed the AC2 breaker setting, the AC breaker trips. The breaker may not trip if Gen Support is enabled and Gen Amps is configured not to exceed the generator's rated output current.
AC2 Lo Volt	Minimum acceptable input voltage level from the generator.
AC2 Hi Volt	Maximum acceptable input voltage level from the generator.
AC2 Lo Freq	Minimum acceptable generator input frequency.
AC2 Hi Freq	Maximum acceptable generator input frequency.

For default settings, see “AC Menu” on page B-4.

## Grid Support Settings

The Grid Support Settings menu contains configuration options for grid-tie operation. To enable all these settings, Grid Support must be enabled in the Setup menu (see “XW Inverter/Charger Setup Menu” on page 3–2).

**Important:** Grid support and Sell functions are modes of operation that are subject to local and/or national grid interconnection requirements in most jurisdictions. It is the responsibility of the installer and system operator to ensure that all applicable procedures and technical requirements are complied with before turning on either of these modes. The interconnect codes and standards with which the XW Inverter/Charger complies are listed in the Specifications section on page A–8.

**Note:** Upon startup, the XW Inverter/Charger does not enable Grid Support functions for five minutes (300 seconds). During this period the XW Inverter/Charger connects to AC input and determines whether the utility grid voltage and frequency are stable and within nominal range. If Grid Support is enabled, the Inverter Information Panel also displays a 300-second countdown during this period. For more information, see “Islanding Protection” on page 1–5.

**Table 3-6** Grid Support Settings menu

Item	Description
Grid Supp Volts	Sets the level to which the batteries will be discharged when the inverter is selling power to the grid or supporting the power grid by providing additional power to the loads. This setting is not adjusted for the battery temperature if the temperature sensor is installed.
Sell	Turns Sell mode on and off. When Sell is enabled, the XW Inverter/Charger AC output is divided between powering loads and delivering power to the utility grid. Sell mode requires the battery voltage to be above the Grid Supp Volts. All configurations must comply with local and national electrical codes.
Max Sell Amps	Sets the maximum AC amps allowed to be delivered to the utility grid from a solar array and/or the batteries during grid-tie operation. This setting is only used if Sell mode is enabled. The Max Sell Amps must be less than 80 per cent of the selected AC1 breaker setting. If set higher, the breaker setting will override the Max Sell Amps setting to avoid tripping the breaker.
Load Shave	Enables or disables the Load Shave feature. Load Shave allows the XW Inverter/Charger to support the grid in powering local loads during a defined window of time (set using Load Shave Start and Load Shave Stop). When in this mode, the XW Inverter/Charger operates until the batteries discharge to the LBCO threshold, after which the unit reverts to AC pass-through. The charger is automatically blocked during the Load Shave time window.

**Table 3-6** Grid Support Settings menu

Item	Description
Load Shave Amps	Sets the maximum amount of current that can be drawn from the AC1 (grid) input by the loads and battery charger combined. This setting determines the amperage level at which the inverter starts drawing power from the batteries to add to the utility power to meet the demand of the loads. Typically, this value is set to the size of the AC circuit breakers feeding the inverter's AC input.
Load Shave Start	Sets the time of day that the Load Shave feature operates. This feature is suited for regions where local utilities impose peak usage surcharges. The inverter provides load shaving power as long as battery voltage is above the Low Batt Cut Out setting.
Load Shave Stop	Sets the time of day that the Load Shave feature stops operating. If Load Shave is enabled and Load Shave Start and Load Shave Stop are set to the same time, the XW Inverter/Charger load shaves continuously.

For default settings, see “Grid Support Menu” on page B-5.

## Energy Management

The XW Inverter/Charger can be programmed to control how and when to use utility power. Advanced features allow management of peak loads and time-of-use billing.

### Charger Block

See “Using Charger Block” on page 3-13.

### Grid Support

---

**Important:** Grid support and Sell functions are modes of operation that are subject to local and/or national grid interconnection requirements in most jurisdictions. It is the responsibility of the installer and system operator to ensure that all applicable procedures and technical requirements are complied with before turning on either of these modes. The interconnect codes and standards with which the XW Inverter/Charger complies are listed in the Specifications section on page A-8.

---

The Grid Support feature allows the XW Inverter/Charger to support local loads by converting excess capacity from external DC sources connected to its battery bank. Examples of external DC sources are charge controllers, micro-hydro, and wind turbines.

For Grid Support to function, Grid Support must be enabled on the Setup menu and the battery voltage must be above the Grid Supp Volts setting.

There are two modes of operation within Grid Support.

**Grid Support enabled, Sell disabled** In this mode, available excess DC power is converted and used to power local loads. No power is exported to the utility. If the local load demand exceeds the available power from the external DC sources,

power is then drawn from the utility to support the load. However, if the local load demand is less than the power available from external DC sources, the net excess power from the external DC sources is not converted and hence not used.

**Grid Support enabled, Sell enabled** In this mode, all available excess DC power is first used to power local loads. Any remaining power is exported to the utility grid.

## Grid Support and Battery Charging

**Charge Cycle settings** With the charger enabled, the XW Inverter/Charger enters Grid Support mode only after completing a charge cycle when it is first powered up or reconnected to the grid. It is recommended to set the Charge Cycle to 2-stage (default) to allow Grid Support to function immediately after the Absorption charge stage. See “Charger Settings Menu” on page 3–9.

**Grid Support modes** Grid Support can be configured to operate in one of two modes.

**Fixed battery voltage** This mode is suitable for systems with DC sources that are not connected to the XW Inverter/Charger through Xanbus or mixed systems which have both Xanbus connected XW Solar Charge Controllers and other DC sources. In this mode, the Grid Supp Volts setting is set about 0.5 volts below the voltage provided by the DC source (typically the float voltage setting of the DC source or charge controller).

In fixed battery voltage mode the XW Inverter/Charger tries to regulate the battery voltage to the Grid Supp Volts setting by converting the available DC power to AC power to support the loads or export to the utility grid. Because the battery bank voltage may not reach Bulk/Absorption voltages in this mode, it is recommended to occasionally force a full charge cycle by either temporarily disabling Grid Support or forcing a Bulk charge cycle from the grid (see “Force Chg” on the “XW Inverter/Charger Setup Menu” on page 3–2).

**Enhanced interactive mode** This mode is suitable for XW Systems with only XW Solar Charge Controller(s) networked to XW Inverter/Charger(s) through Xanbus. In this mode, the Grid Supp Volts setting is set above the charge controller’s Bulk and Absorb voltages (for example, 32 volts on a 24-volt system and 64 volts on a 48-volt system).

In enhanced interactive mode the XW Inverter/Charger automatically tracks the XW Solar Charge Controller voltage as it transitions through all charge states (from Bulk to Absorb to Float). This allows the XW System to execute a full battery charge cycle while still converting excess DC power to AC power to support the loads or export to the utility grid. Since this mode allows the battery bank voltage to reach absorption levels (when PV harvest is adequate), the state of health of the battery is improved.

## Peak Load Shaving

Many utilities impose a surcharge on their customers based on the peak load used by a facility. To reduce utility peak demand charges, the inverter can be configured (using the Load Shave Amps setting) to limit the maximum draw the AC loads place on the utility. The inverter can be programmed to provide power

above a specified level, eliminating the surcharge. When the utility current draw reaches the maximum level, the inverter assists by providing power from the batteries to the loads.

For Peak Load Shaving to be effective, all loads must be connected to the inverter. For large loads, multiple (or stacked) inverters may be required.

To further ensure the batteries are able to supplement the power requirements of the connected load, an additional source of power (solar, wind or hydroelectric) is recommended.

Peak Load Shaving can also be used in addition to the time-of-use metering.

## Time-of-Use Metering

Utilities use time-of-use metering to determine utility charges during peak usage hours and to impose a surcharge. The XW Inverter/Charger can be configured (using the Load Shave Start, Load Shave Stop and Charger Block settings) to overcome these peak charges by using utility power to charge the battery bank during the inexpensive energy hours and consuming the battery energy during expensive energy hours.

For example, if Charger Block is set between 9:00 AM and 10:00 PM and Load Shave is set between 6:00 PM and 9:00 PM, charging on AC1 stops at 9:00 AM and continues to pass utility AC through to the loads. If charging is required during the charger block period, and AC Priority is set to AC2, the XW Inverter/Charger can use any AC source connected to AC2. Loads will transfer to the AC source on AC2 as well. The inverter connects to the utility grid at 6:00 PM and supports loads using the batteries. The inverter continues to run until 9:00 PM. The XW Inverter/Charger then stops supporting the utility grid and passes utility AC through to the loads. At 10:00 PM utility AC begins maintaining the batteries based on the battery charger settings.

The above example allows an external renewable energy source to be utilized as a primary charging source during a desired time window. The charger (using utility AC connected to AC1) can then be used to supplement the battery charging when the rates utility rates are low.

When using the system for time-of-use metering, the system should be designed with a battery capacity large enough to support loads during the entire peak rate period without reaching the Low Battery Cut Out setting.

To further ensure the batteries are able to support the loads, an additional source of power (solar, wind or hydroelectric) is recommended. Depending upon the capacity of the system, certain heavy loads should only be run during non-peak periods.

---

**Note:** If the batteries reach their Low Battery Cut Out voltage, the XW Inverter/Charger automatically reconnects to the utility grid to maintain the connected load.

---

---

## Generator Support Settings

Generator support allows power to be automatically drawn from the batteries to assist an AC generator to support heavy loads (loads that exceed the available current from the generator).

Generators have a limited output current and it is possible to reach this limit when operating heavy loads. The XW Inverter/Charger is designed to assist the generator when heavy current demands load down the generator by supplying additional power from the batteries.

In addition, the battery charger can back off its charging current to the batteries so the combined load of the charger and load support does not exceed the capacity of the generator or trip its output breakers or fuses.

---

**Note:** Running and Start-up (Peak) currents are limited to the maximum current limits of the inverter.

---

**Table 3-7** Gen Support Menu Values

Setting	Description
GenSupp Mode	Turns the Generator Support feature on and off.
GenSupp Amps	Sets the generator load level at which the XW Inverter/Charger supplies power from the batteries to support the generator.

For default settings, see “Gen Support Menu” on page B-5.

## Auxiliary Output Settings

The Aux menu allows you to enable and configure the auxiliary output. The auxiliary output provides 12 volts DC at 250 milliamps to power a relay, indicator light or alarm.

**Table 3-8** Aux Menu Values

Setting	Description
Manual Aux	Sets the state of the Auxiliary Output. ManualOn or ManualOff allow manual control of the Auxiliary Output. When set to Automatic, a trigger source can then be selected.
Active Lvl	Sets the mode (polarity) of the aux output. When triggered, the output can be active high (12 Vdc output turns on) or active low (output is high until the trigger turns it off).
Trigger Src	Selects the desired condition (Trigger Source) to activate the Aux Output. The Trigger Source options are LowBattV, HighBattV, LowBattTemp, HighBattTemp, and Fault.
Trigger Level	Sets the voltage or temperature level (depending on the selected trigger source) at which the aux output is activated. If the selected Trigger Source is a Battery Voltage, the range also varies according to the nominal battery voltage of your system.
Trigger Delay	Sets a delay period between when the trigger occurs and when the aux output is activated.
Clear Level	Sets the voltage or temperature level (depending on the selected trigger source) at which the aux output becomes inactive.
Clear Delay	Sets a delay period between when the Clear Level setting occurs and when the aux output becomes inactive.

For default settings, see “Aux Menu” on page B-6.

---

**Important:** Changing the Trigger Level resets the auxiliary output. If an auxiliary output trigger is active, changing the trigger level will clear the trigger.

---

Trigger Source  
Descriptions

**Low Batt Voltage** Activates the Auxiliary Output when the battery voltage falls below the Low Batt Voltage setting for the trigger delay time. The Auxiliary Output turns off when the battery voltage rises above the Clear setting for the Clear Delay time. Use this setting if you want the auxiliary output to control a relay to disconnect loads from a battery that is nearly discharged, or to activate a low-battery-voltage alarm such as a buzzer or light.

**High Batt Voltage** Activates the Auxiliary Output when the battery voltage rises above the Hi Batt Voltage setting for the trigger delay time. The Auxiliary Output turns off when the battery voltage falls below the Clear setting for the Clear Delay time. This setting is useful for:

- Installations that have another external charging source such as a wind generator or hydro generator connected directly to the batteries. The XW Inverter/Charger Auxiliary Output can control a relay to disconnect the external charging source from the battery when the battery is in danger of being overcharged, or control a relay to turn on a diversion load.
- Activating a high-battery-voltage alarm such as a buzzer or light.
- Activating a vent fan to disperse hydrogen from the battery compartment when the batteries reach their gassing voltage.

**Low Batt Temp** Activates the Auxiliary Output when the battery temperature falls below the Low Batt Temp setting for the trigger delay time. The Auxiliary Output turns off when the battery temperature rises above the Clear setting for the Clear Delay time. Battery temperature is measured with a battery temperature sensor. Do not use this setting if a battery temperature sensor is not installed. With this setting, the auxiliary output can turn on an indicator alarm if the batteries are too cold. A battery with frozen electrolyte will not accept a charge.

**High Batt Temp** Activates the Auxiliary Output when the battery temperature rises above the Hi Batt Temp setting for the trigger delay time. The Auxiliary Output turns off when the battery temperature falls below the Clear setting for the Clear Delay time. Battery temperature is measured with a battery temperature sensor. Do not use this setting if a battery temperature sensor is not installed. With this setting, the auxiliary output can turn on a fan to cool the battery compartment.

**Fault** Activates the Auxiliary Output when a fault occurs. The Auxiliary Output clears when the fault is cleared.



## Multi-Unit Config Menu

The Multi-Unit Config menu configures the XW Inverter/Charger to operate as a part of a multi-unit installation.

**Important:** Accessing this menu automatically places the XW Inverter/Charger in Standby mode. When entering the Multi-Unit Config menu, the unit also identifies itself by flashing all front panel lights. After exiting the Multi-Unit Config menu, the XW Inverter/Charger returns to Operating mode and the front panel lights stop flashing.

**Table 3-9** Multi-Unit Config menu

Item	Description	Default	Range
Dev Name	Allows customization of the default device name. This setting is optional and does not affect operation. See “Setting the Device Name” on page 3–23.	n/a	n/a
Dev Number	Allows setting of a unique unit number in a multiple-unit system. See “Setting the Device Number” on page 3–24.	00	00–31
Inverter Mode	For a multi-unit single-phase system to operate, one XW Inverter/Charger must be configured to “1Ph Master” and the rest as “1Ph Slave,” otherwise a system-wide fault is asserted. For three-phase systems, one unit must be configured as the master for each line: 3PhL1Master, 3PhL2Master, and 3PhL3Master. Additional units on each phase must be configured as “slave” units: 3PhL1Slave, for example.	1PhMaster	For single-phase, three-wire models: 1Ph Master, 1Ph Slave. For three-phase systems, see “Three-Phase Configuration” on page 3–25.
Connections	Select to display the Connections menu. See “Connections Menu” on page 3–27.	n/a	n/a

When installing a multi-unit system, each setting on the Multi-Unit Config menu (except for “Dev Name”) must be configured for each XW Inverter/Charger in the system. The Multi-Unit Config settings should be configured in the following order:

- Dev Number
- Inverter Mode
- Connections.

### Setting the Device Name

The “Dev Name” setting allows you to customize the name of the XW Inverter/Charger as it is displayed on other screens and menus.

The characters available are:

- A to Z
- a to z
- 0 to 9
- space.

**Note:** Increasing the number of characters in a device name may cause other text on the same line to run off the edge of the screen. Device names should be limited to 10 characters or less.

---

**To customize the XW Inverter/Charger name:**

1. On the device setup menu, select Advanced Settings.  
If “Basic Settings” appears instead of “Advanced Settings” on the device setup menu, display “Advanced Settings” by pressing Enter + Up arrow + Down arrow at the same time.
2. Select the Multi-Unit Config menu.
3. Select Dev Name.
4. Press Enter.  
The last letter of the XW Inverter/Charger name is highlighted.
5. Begin customizing the device name.
  - To change the character, press the up or down arrow button. Holding down the button causes the characters to scroll more quickly.
  - To delete the character, press Exit.
  - To add characters, press Enter.
6. When the correct character is shown, press Enter to select it.
7. After pressing Enter to select the last character of your customized device name, press Enter again to return to the menu.

## Setting the Device Number

Setting the device number gives a Xanbus-enabled device a unique identity when several devices of the same type are installed in the networked power system. When each identical device has a unique number, the System Control Panel can correctly identify and display status information for each device.

A device number consists of two digits ranging from 00 (default) to 31.

If only one of each device is installed in the networked power system, you do not need to set the device number. However, setting the device number to a value other than 00 is recommended in case you need to use the “Restore Defaults” command. After performing the command, checking that the device number has returned to 00 indicates that the command was successfully completed.

**To set the XW Inverter/Charger device number:**

1. On the XW Inverter/Charger Setup menu, select Advanced Settings.  
If “Basic Settings” appears instead of “Advanced Settings” on the Setup menu, display “Advanced Settings” by pressing Enter + Up arrow + Down arrow simultaneously.  
On the Advanced Settings menu, select Multi-Unit Config and press Enter.
2. On the Multi-Unit Config menu, select Dev Number. See Figure 3-6.
3. Press Enter to highlight the instance number.
4. Use the up and down arrow buttons to adjust the two-digit identifier number.

5. Press Enter.

XW6048 01:Multi	
Dev Name	[XW1]
Dev Number	[01]
Invtr Mode	[1PhSlave]
Connections	

Figure 3-6 Setting a Device Number

## Three-Phase Configuration

When installed in a three-phase system, the XW Inverter/Chargers check for the existence of a master on each phase. If there is not a master unit on each phase, a system wide fault (F66) is asserted. Each XW Inverter/Charger has to be associated with a phase or line. To associate an XW Inverter/Charger with a phase or line, select one of six available three-phase Inverter Modes. The three-phase Inverter Modes are shown in Table 3-10. See also Figure 3-7 on page 3-26.

Table 3-10 Three-phase Inverter Modes

Line or Phase	Inverter Mode	Role Assignment <sup>a</sup>	Suggested Device Number
Line-1 or Phase-A	3Ph L1 Master <sup>b</sup>	Phase-A or Line-1 Master	10
	3Ph L1 Slave	Phase-A or Line-1 Slave	11
Line-2 or Phase-B	3Ph L2 Master	Phase-B or Line-2 Master	20
	3Ph L2 Slave	Phase-B or Line-2 Slave	21
Line-3 or Phase-C	3Ph L3 Master	Phase-C or Line-3 Master	30
	3Ph L3 Slave	Phase-C or Line-3 Slave	31

a. Each phase can support one master unit and one slave unit.

b. The L1 Master is also the master inverter/charger for the entire system. The system master broadcasts phase synchronizing pulses through its sync port, and each phase master controls the other units on its respective phase.

**Note:** Device Numbers given here are only suggested to facilitate identifying devices on the system as well as phase association from a device's name and number. You can also customize the naming as desired. Conflicting Device names are allowed and will not cause faults in the system or devices.

**Six-Inverter Three-Phase Sample Configuration**  
 Two inverters per phase, with a common load, common grid and common generator.

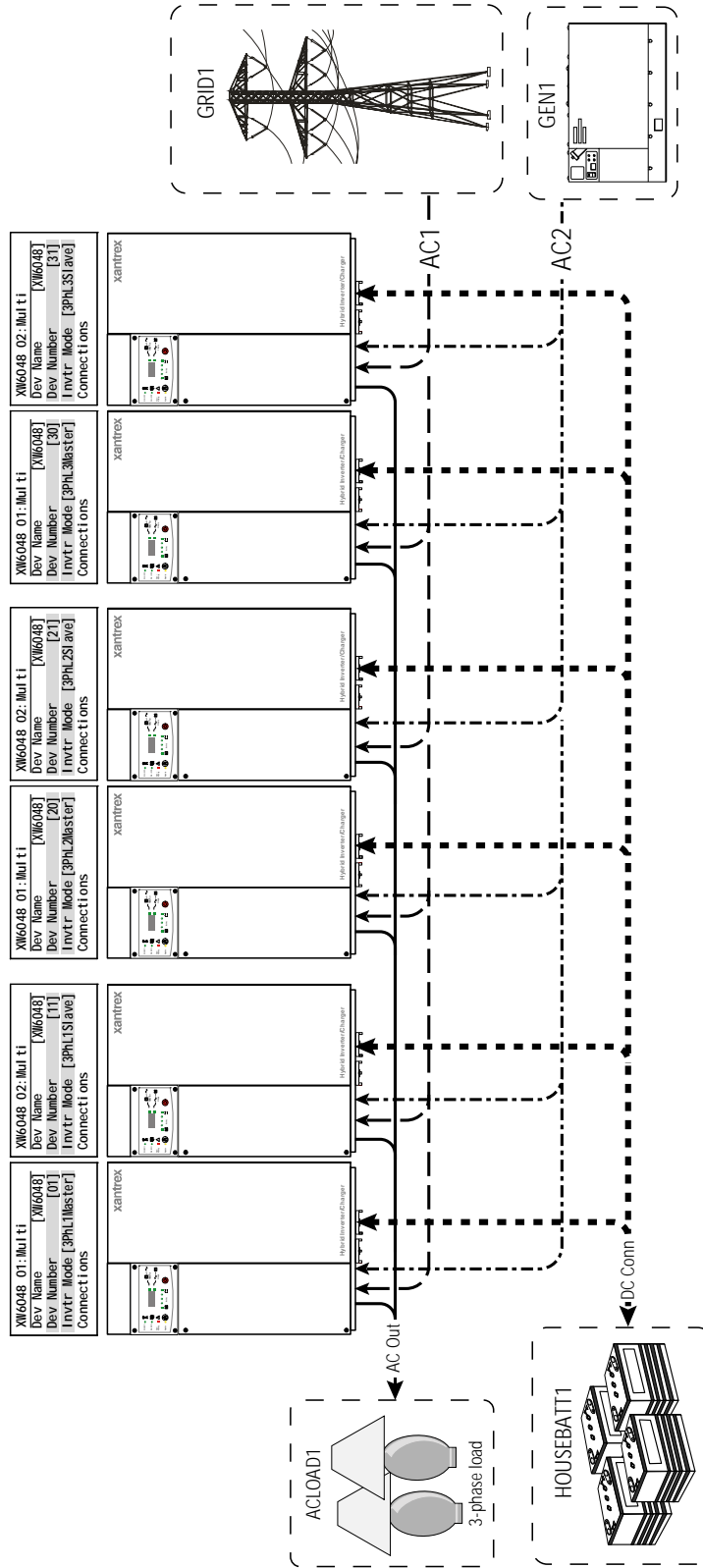

Figure 3-7 Three-Phase Configuration Example

## Connections Menu

The Connections menu contains additional settings to allow the XW Inverter/Charger to function as part of a multi-unit networked system.

Setting the connections for a Xanbus-enabled device provides a way of identifying non-network connections for Xanbus-enabled devices (see Figure 3-8) and enhancing networked power system management. When connections are set, devices of different types can detect that they share, for example, a common DC input source, or a common grid or generator source.

In multi-unit networked systems, inverter/chargers can be stacked to produce increased charge current. To achieve this functionality, the devices must be configured to the same DC connection, such as House Battery Bank 1. The inverter/chargers will collaborate on battery charging by listening to other units on this shared DC connection.

---

**Important:** When configuring multiple networked XW Inverter/Chargers with the System Control Panel, DC connections must be set to the same battery bank. If one of the units is set with a different DC connection, a system configuration fault (F66) occurs.

Although the XW Power System does support multiple XW Inverter/Chargers connected to multiple battery banks, such configurations cannot be set using the System Control Panel. A special configuration application provided by Xantrex is required. To configure such a system, contact your installer or Xantrex.

---

**Table 3-11** Connections menu

Item	Description
DConn	DC Input and Output connection. This is the common DC connection between inverter/chargers, charge controllers, and Automatic Generator Start.
ACOut	AC Output connection. This connection specifies a common AC output connection between inverter/chargers. The AC Out connection has to be configured so that the XW Inverter/Chargers know if they are connected to the same load or not. If connected to the same load, select the same name on all units; for example, "ACLoad1." If connected to separate load banks, use different names for the AC Out connection on each unit; for example, "ACLoad1" on one unit and "ACLoad2" on the other.
AC1	AC1 input connection. This connection specifies a common AC Line 1 input for multiple inverter/chargers.
AC2	AC2 input connection. This connection specifies a common AC Line 2 input for multiple inverter/chargers.

For default settings, see "Connections Menu" on page B-6.

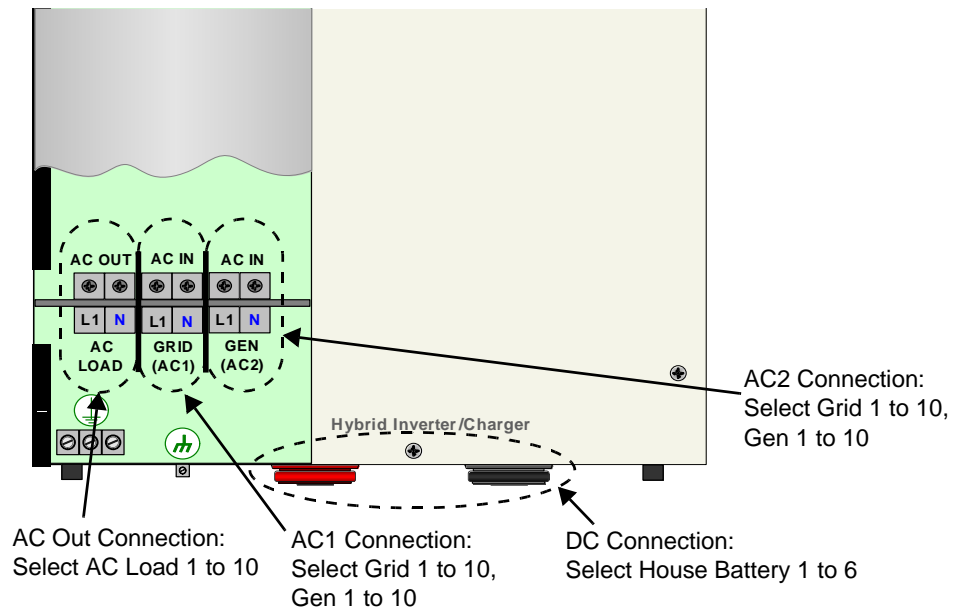

Figure 3-8 XW Inverter/Charger Connections Representation

Operating without connections

AC1 and AC2 connections can be set to “None” if operating without a connection to a specific power source. Only stand-alone devices (in a system that includes only the device and a System Control Panel) may be configured this way. Note that this is not a necessary configuration step as the system will still operate with the default settings. Using “None” where no AC source is used only serves as a label in this case and does not modify the behavior of a unit.

## Copying Settings From Another Unit

The “Copy from” command allows quick configuration of an XW Inverter/Charger. After selecting another XW Inverter/Charger in the system to copy settings from, common parameters are copied from the selected XW Inverter/Charger to the XW Inverter/Charger being configured.

The following settings are copied from the selected unit:

- Inverter Settings
- Charger Settings
- AC Settings
- Grid Support Settings (except the Sell setting)
- Gen Support Settings.

The following settings are not copied between units:

- Inverter Mode
- Device Number
- Device Name
- Auxiliary Output settings.

## Resetting the XW Inverter/Charger to Default Settings

The Restore Defaults command returns the XW Inverter/Charger to factory default settings. After using the Restore Defaults command, the XW Inverter/Charger is no longer configured for the power system.

### To restore XW Inverter/Charger default settings:

1. On the Advanced Setup menu, select Restore Defaults.  
Warning W252 appears, asking to confirm the Restore Defaults command.
2. To cancel the command, press Exit. To continue with the Restore Defaults command, press Enter.

---

**Important:** If a warning is already active in the system, selecting Restore Defaults brings up the Warning List, with warning W252 at the top. Press Enter to view W252 and continue with the Restore Defaults process.

---



### CAUTION: Equipment damage

Do not use the Restore Defaults command while the XW Inverter/Charger is operating. De-energize the power system and disconnect the XW Inverter/Charger AC input before using the Restore Defaults command. Reconfigure the XW Inverter/Charger before reconnecting the AC input and re-energizing the power system.

---

## Using the Advanced Features

Table 3-12 Advanced Features menu

Item	Description
RPO	Remote Power Off. RPO enables or disables the remote power off function. Enable this setting if an external shut-off switch has been connected to the XW Inverter/Charger Aux port. See the Installation Guide for more information about the Aux port.
Power Save	When enabled, Power Save mode can reduce tare loss from the battery by reducing output from 230 volts to 210 volts when the loads are less than 100 watts. When the XW Inverter/Charger detects loads higher than 100 watts, the inverter/charger produces the full 230 volts. Power Save mode is disabled by default.





# A

# Specifications

Appendix A, “Specifications” provides the electrical and mechanical specifications for the XW Hybrid Inverter/Charger.

## Electrical Specifications

**Table A-1** XW Hybrid Inverter/Charger Electrical Specifications

	XW6048	XW4548	XW4024
Continuous Output Power	6,000 W	4,500 W	4,000 W
Surge Rating	12,000 W (15 s)	9,000 W (20 s)	8,000 W (20 s)
Surge Current	53 A <sub>rms</sub> (15 s)	40 A <sub>rms</sub> (20 s)	35 A <sub>rms</sub> (20 s)
Peak Efficiency	95.4 %	95.6 %	94.0 %
Full Load Efficiency	92 %	93.0 %	89 %
Waveform	True Sine Wave		
Idle Consumption—invert mode, no load	28 W	26 W	24 W
Idle Consumption—search mode	< 7 W		
AC Output Voltage	230 Vac $\pm$ 3%		
AC Input Voltage Range (Bypass/Charge Mode)	165–280 Vac		
AC Input Breaker	60 A double-pole		
AC Input Frequency Range (Bypass/Charge Mode)	45–55 Hz (default) 40–68 Hz (allowable)		
AC Output Continuous Current	26.1 A	19.6 A	17.4 A
AC Output Frequency	50.0 $\pm$ 0.1 Hz		
Total Harmonic Distortion	< 5% at rated power		
Automatic Transfer Relay	56 A		
Auxiliary Relay Output	0–12 Vdc, maximum 250 mA DC		
DC Input Voltage (Nominal)	50.4 Vdc	50.4 Vdc	25.2 Vdc
DC Input Voltage Range	44–64 Vdc	44–64 Vdc	22–32 Vdc
DC Current at Nominal Power	131 A	96 A	178 A
Continuous Charge Rate at Nominal Voltage	100 A	85 A	150 A
Power Factor Corrected Charging	PF (0.99)		

## XW Inverter/Charger Overload Capability

Loads connected to the inverter are seldom constant, and large loads are often operated for short periods. To accommodate larger loads, the XW can temporarily exceed its continuous output power rating. The graphs below illustrate approximate operation time versus load.

Inverter operation time during overload is limited by both inverter internal temperature protection and by the product of AC output current and elapsed time.

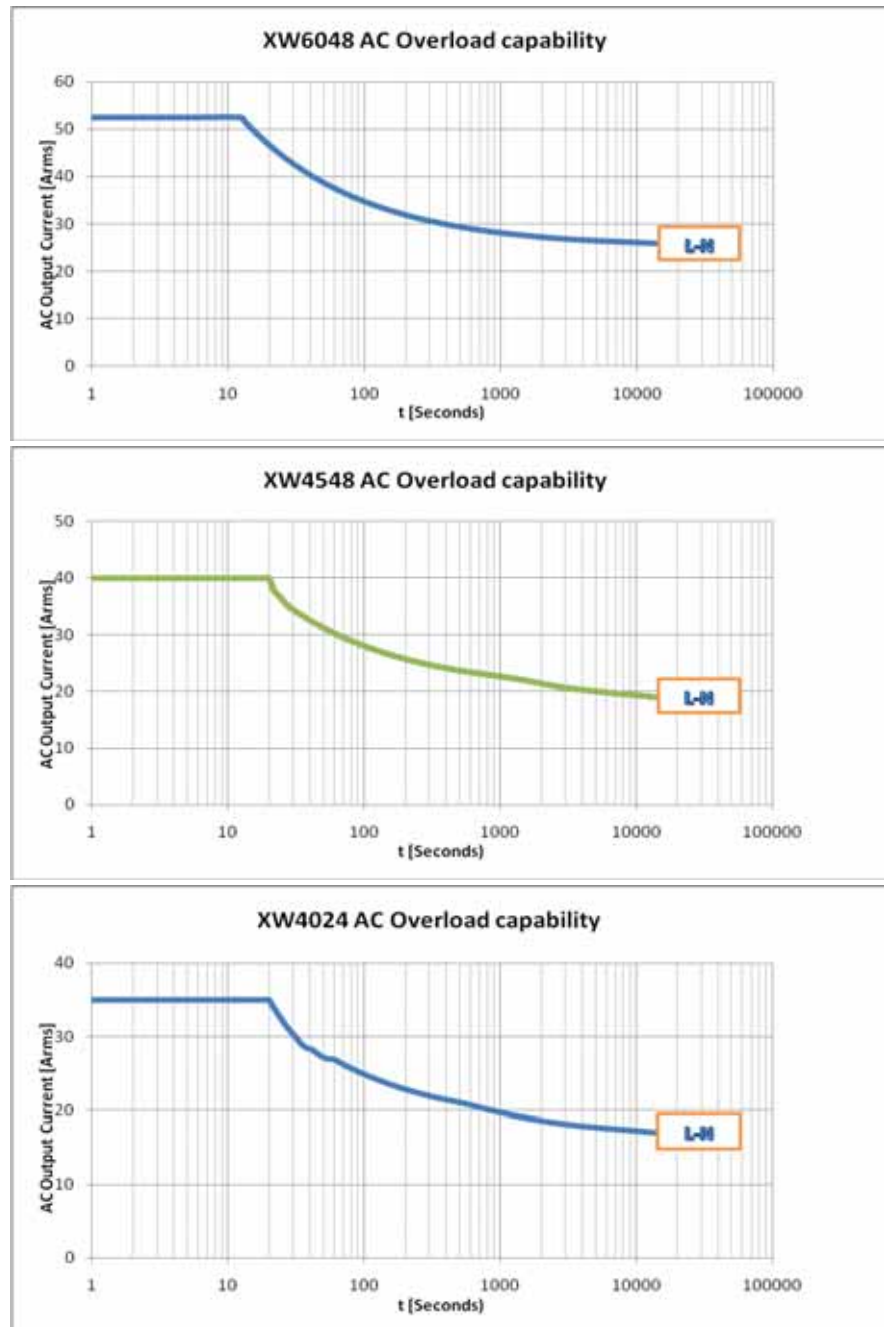

Figure A-1 XW Inverter/Charger AC Overload Capability

## Output Power Versus Ambient Temperature

When the internal temperature of the XW Inverter/Charger exceeds a preset limit, it begins to limit output power automatically to ensure maximum internal temperatures are not exceeded.

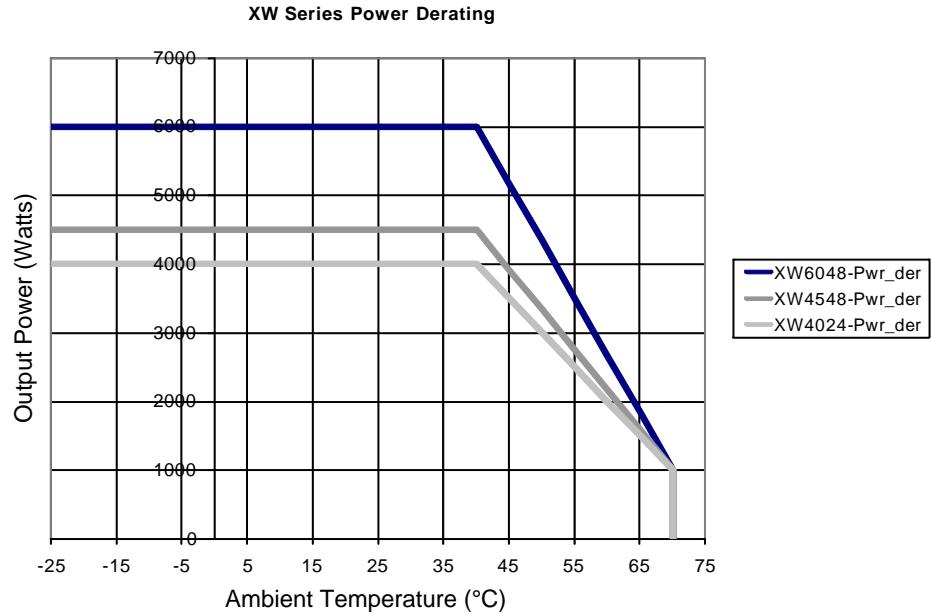
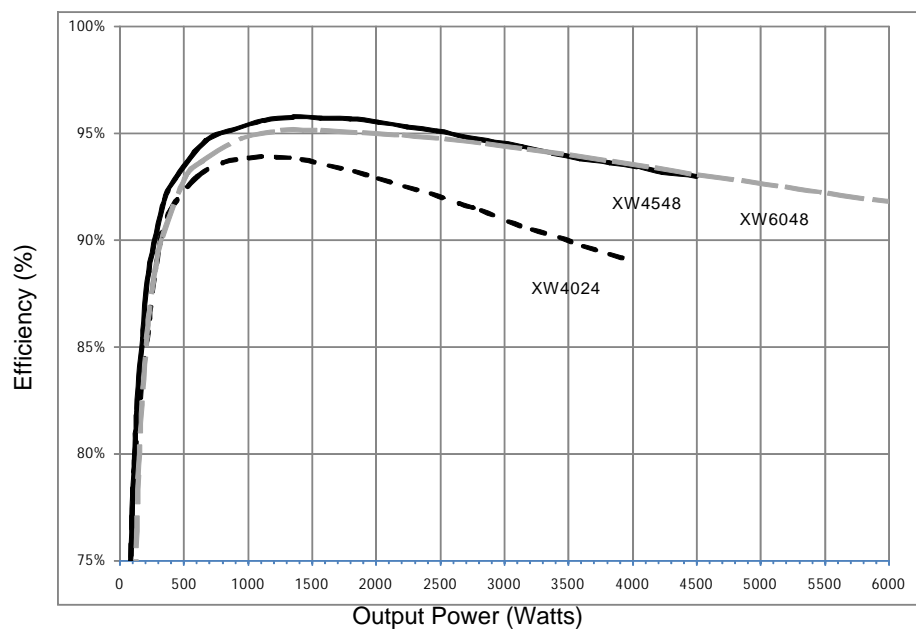

Figure A-2 Output Power Versus Ambient Temperature

## XW Inverter/Charger Efficiency

### Inverting Efficiency (Typical)



Charging Efficiency (Typical)

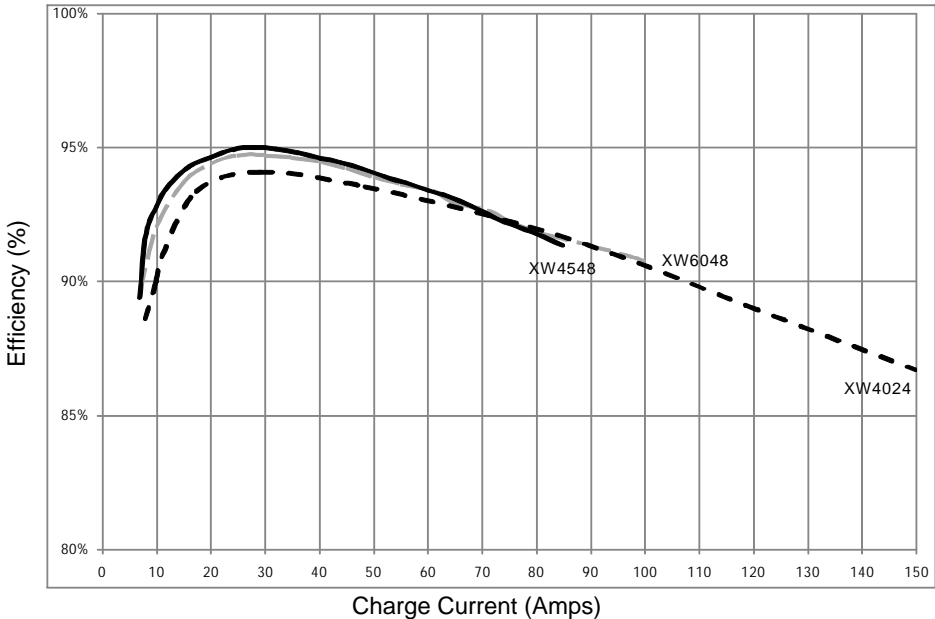

Charging Efficiency (Power Factor Corrected)

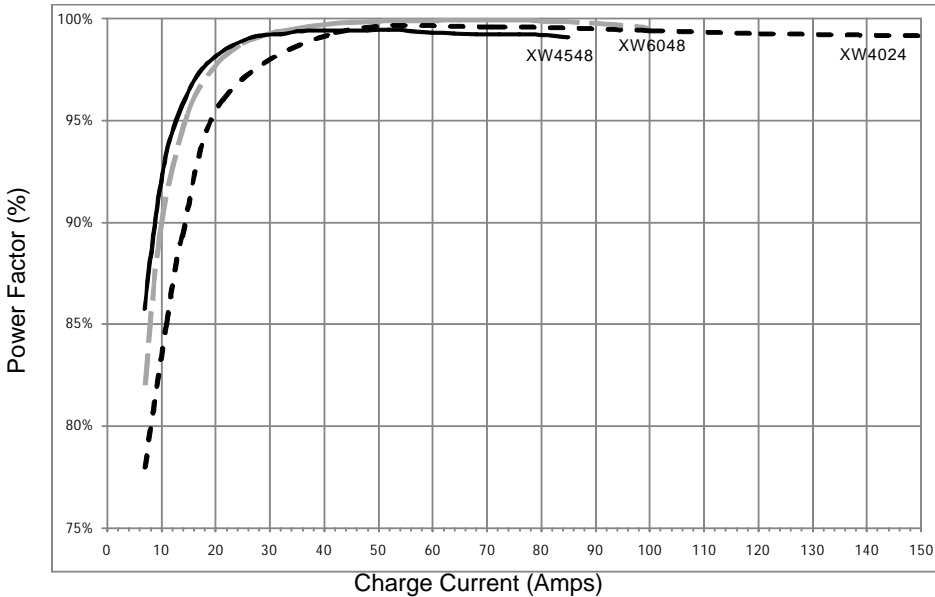

### Grid-Tie Sell Mode Efficiency (Typical)

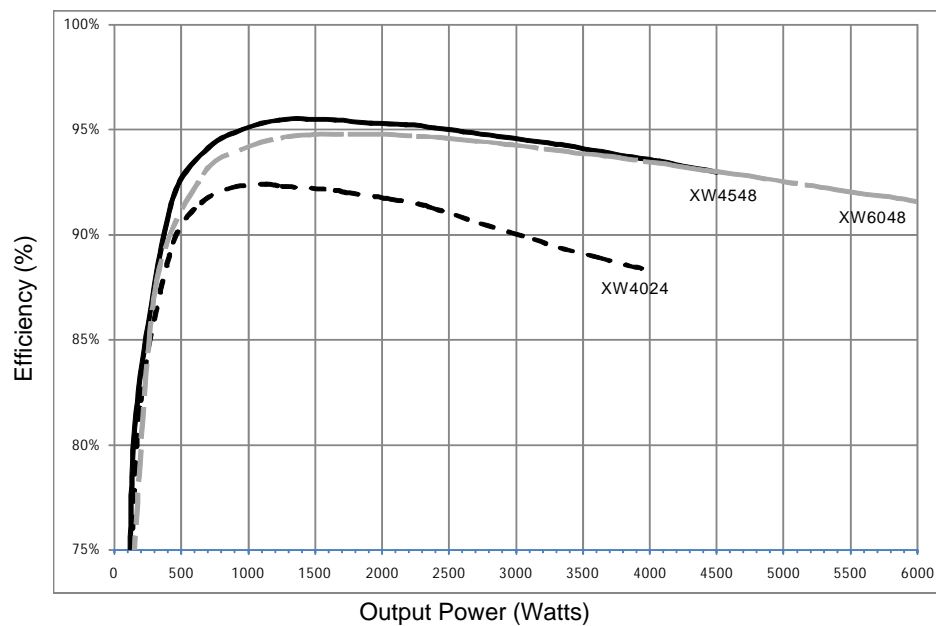

## Mechanical Specifications

**Table A-2** XW Hybrid Inverter/Charger Mechanical Specifications

Model	XW6048	XW4548	XW4024
Supported Battery Types	Flooded (default), Gel, AGM, Custom		
Battery bank size	100–2000 Ah		
Non Volatile Memory	Yes		
Display Panel	Status LEDs indicate AC In status, faults/warnings, equalize mode, battery level. Three-character display indicates output power or charge current, fault/warning codes. On/Off and equalize button		
System Network	Xanbus (publish-subscribe network, no need for hubs or special cards)		
Enclosure Type	IP 20, indoor, unheated		
Rated Temperature Range (meets all specifications)	0–40 °C		
Operational Temperature Range	-25–70 °C		
Storage Temperature Range	-40–85 °C		
Inverter Dimensions (H × W × D)	580 × 410 × 230 mm		
Shipping Dimensions (H × W × D)	711 × 572 × 394 mm		
Inverter Weight	57 kg	52 kg	52 kg
Shipping Weight	60 kg	55 kg	55 kg

## Accessories

Accessory	Part Number
Power Distribution Panel	865-1015
Conduit Box	865-1025
Inverter #2 Connection Kit	865-1020
XW-MPPT60-150 Solar Charge Controller	865-1030-1
XW System Control Panel	865-1050
XW Automatic Generator Start	865-1060
Network cables	3 ft (0.9 m): 809-0935 25 ft (7.6 m): 809-0940 50 ft (15.2 m): 809-0941 75 ft (22.9 m): 809-0942
Network terminators	Male (2 per pack): 809-0901

## Regulatory Approvals

CE Marked and complies with the following:

Low Voltage Directive 2006/95/EC, per:

- EN50178 “Electronic Equipment for Use in Power Installations”.

EMC Directive 2004/108/EC, per:

- EN61000-6-3 “Emission Standard for Residential, Commercial, and Light-Industrial Environments”
- EN61000-6-1 “Immunity for Residential, Commercial, and Light-Industrial Environments”

## Interconnect Codes and Standards



# B

## Default Settings

Appendix B contains the default configuration settings and ranges for the XW Hybrid Inverter/Charger. Configuration settings can be viewed and changed using the XW System Control Panel.

## Default Settings and Ranges

Figure B-1 shows how the XW Inverter/Charger configuration menus are organized in the XW System Control Panel.

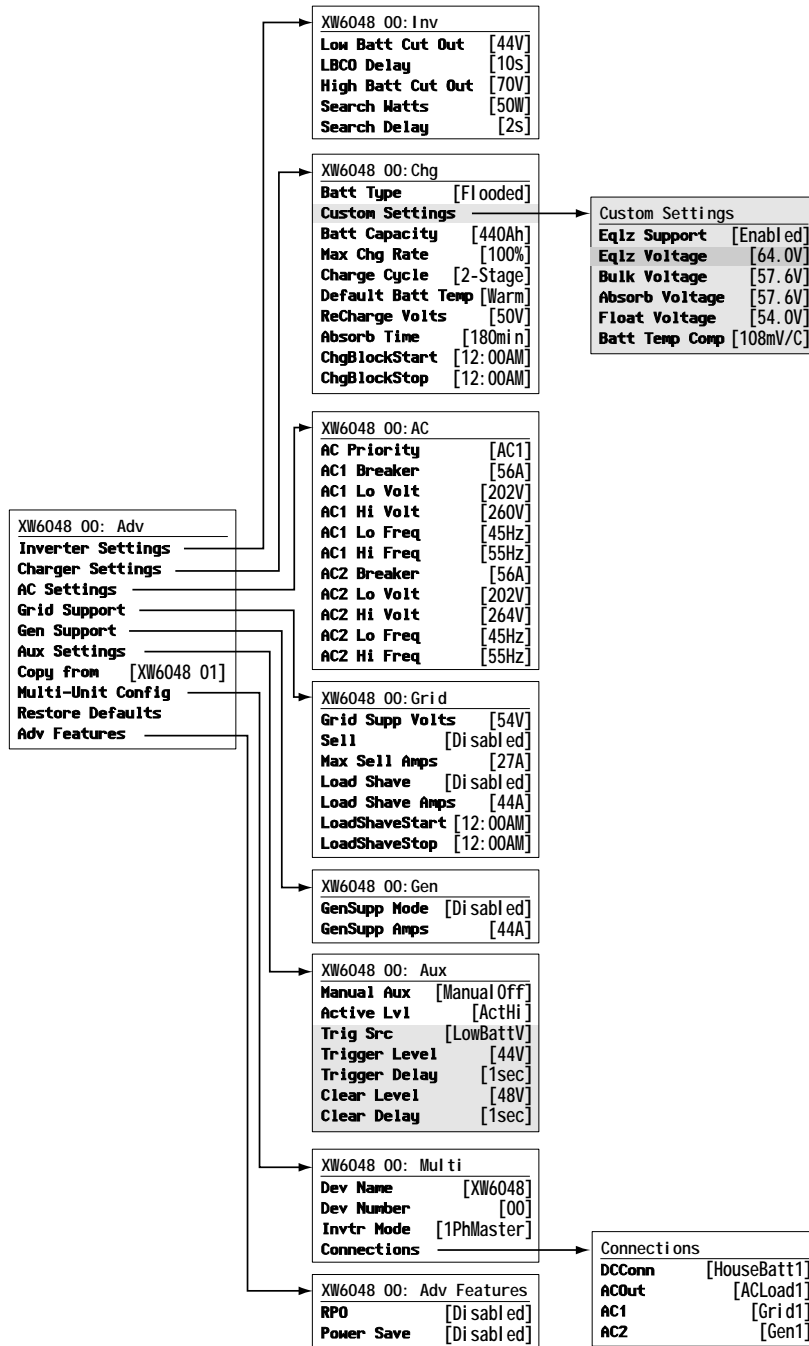

Figure B-1 Configuration Menu Map (Advanced)

## Inverter Menu

Item	Default Setting		Range		Step Size
	24 V	48 V	24 V	48 V	
Low Batt Cut Out	22V	44V	20–24V	40–48V	0.1
LBCO Delay	10s		0–600s		1
High Batt Cut Out	35.0V	70.0V	29.0–35.0V	58.0–70.0V	0.1
Search Watts	50W		25–255W		5
Search Delay	2s		1–25s		1

## Charger Menu

Item	Default Setting		Range		Step Size
	24 V	48 V	24 V	48 V	
Batt Type	Flooded		Flooded, Gel, AGM, Custom		n/a
Batt Capacity	440Ah		50–10000Ah		1
Max Chg Rate	100%		10–100%		1
Charge Cycle	2-Stage		2-Stage, 3-Stage		n/a
Default Batt Temp	Warm		Cold, Warm, Hot		n/a
ReCharge Volts	25.0V	50.0V	20.0–27.0V	40.0–54.0V	0.1
Absorb Time	180min		1–480min		1
Chg Block Start	12:00 AM		12:00 AM–11:59 PM, 00:00–23:59		1
Chg Block Stop	12:00 AM		12:00 AM–11:59 PM, 00:00–23:59		1

## Custom Battery Menu

Item	Default Setting <sup>a</sup>		Range		Step Size
	24 V	48 V	24 V	48 V	
Eqlz Support	Enabled	Enabled	Enabled, Disabled		n/a
Eqlz Voltage	32.0V	64.0V	27.0–32.0V	54.0–64.0V	0.1
Bulk Voltage	28.8V 28.4V (Gel) 28.6V (AGM)	57.6V 56.8V (Gel) 57.2V (AGM)	20.0–32.0V	40.0–64.0V	0.1
Absorb Voltage	28.8V 28.4V (Gel) 28.6V (AGM)	57.6V 56.8V (Gel) 57.2V (AGM)	20.0–32.0V	40.0–64.0V	0.1
Float Voltage	27V 27.6V (Gel) 26.8V (AGM)	54.0V 55.2V (Gel) 53.6V (AGM)	20.0–32.0V	40.0–64.0V	0.1
Batt Temp Comp	54mV/C (Flooded, Gel) 42mV/C (AGM)	108mV/C (Flooded, Gel) 84mV/C (AGM)	0–90mV/C	0–180mV/C	1

a. Custom battery default settings are based on the Flooded battery default settings. The Gel and AGM default settings are provided here for reference only.

## AC Menu

Item	Default Setting		Range		Step Size
	24 V	48 V	24 V	48 V	
AC Priority	AC1		AC1, AC2		n/a
AC1 Breaker	56A		3–60A		1
AC1 Lo Volt	202V		156–220V		1
AC1 Hi Volt	260V		240–280V		1
AC1 Lo Freq	45Hz		40–49Hz	40–48Hz	1
AC1 Hi Freq	55Hz		52–68Hz		1
AC2 Breaker	56A		3–60A		1
AC2 Lo Volt	160V	202V	156–220V		1
AC2 Hi Volt	264V		240–280V		1
AC2 Lo Freq	45Hz		40–49Hz	40–48Hz	1
AC2 Hi Freq	55Hz		52–68Hz		1

## Grid Support Menu

Item	Default		Range		Step Size
	24 V	48 V	24 V	48 V	
Grid Supp Volts	27.0V	54.0V	23.0–35.0V	46.0–70.0V	0.1
Max Sell Amps	18A	27A (6048), 20A (4548)	0–18A <sup>a</sup>	0–27A (6048), 0–20A (4548)	1
Load Shave Amps	44A		5–48A		1
Load Shave Start <sup>b</sup>	12:00 AM		12:00 AM–11:59 PM, 00:00–23:59		n/a
Load Shave Stop	12:00 AM		12:00 AM–11:59 PM, 00:00–23:59		n/a

a. This setting is restricted to the selected AC1 breaker size.

b. When Load Shaving is enabled, if Load Shave Start and Load Shave Stop are set to the same time, the XW Inverter/Charger load shaves continuously.

## Gen Support Menu

Setting	Default	Range	Step Size
GenSupp Mode	Disabled	Enabled, Disabled	n/a
GenSupp Amps	44A	3–48A	1

## Aux Menu

Item	Default		Range		Step Size
	24 V	48 V	24 V	48 V	
Manual Aux	ManualOff		ManualOn, ManualOff, Automatic		n/a
Active Lvl	ActiveHigh		ActiveHigh, ActiveLow		n/a
Trigger Src <sup>a</sup>	LowBattV		LowBattV, HighBattV, LowBattTemp, HighBattTemp, Fault		n/a
Trigger Level—LowBattV <sup>b</sup>	22.0V	44.0V	10.0–26.0V	20.0–52.0V	0.1
Clear Level—LowBattV	24.0V	48.0V	10.0–26.0V	20.0–52.0V	0.1
Trigger Level—HighBattV	28.0V	56.0V	24.0–32.0V	48.0–64.0V	0.1
Clear Level—HighBattV	26.0V	52.0V	24.0–32.0V	48.0–64.0V	0.1
Trigger Level—HighBattTemp	45.0°C		30.0–60.0°C		1
Clear Level—HighBattTemp	35.0°C		30.0–60.0°C		1
Trigger Level—LowBattTemp	0.0°C		-30.0–10.0°C		1
Clear Level—LowBattTemp	5.0°C		-30.0–10.0°C		1
Trigger Delay	1s		0–600s		1
Clear Delay	1s		0–600s		1

a. The Trigger Src setting (and the settings below Trigger Src) appear only if Manual Aux setting has been set to Automatic.

b. Trigger Level, Trigger Delay, Clear Level and Clear Delay do not appear if Trigger Src is set to Fault.

## Connections Menu

Item	Default	Range
DCConn	HouseBatt1	HouseBatt1–6, StartBatt1–6
ACOut	ACLoad1	ACLoad1–10
AC1	Grid 1	None, Grid1–10, Gen1–10
AC2	Gen 1	None, Grid1–10, Gen1–10

# Warranty and Return Information

## Warranty

**What does this warranty cover and how long does it last?** This Limited Warranty is provided by Xantrex Technology Inc. ("Xantrex") and covers defects in workmanship and materials in your XW Hybrid Inverter/Charger. This Warranty Period lasts for five years from the date of purchase at the point of sale to you, the original end user customer, unless otherwise agreed in writing. You will be required to demonstrate proof of purchase to make warranty claims.

This Limited Warranty is transferable to subsequent owners but only for the unexpired portion of the Warranty Period. Subsequent owners also require original proof of purchase as described in "What proof of purchase is required?"

**What will Xantrex do?** During the Warranty Period Xantrex will, at its option, repair the product (if economically feasible) or replace the defective product free of charge, provided that you notify Xantrex of the product defect within the Warranty Period, and provided that Xantrex through inspection establishes the existence of such a defect and that it is covered by this Limited Warranty.

Xantrex will, at its option, use new and/or reconditioned parts in performing warranty repair and building replacement products. Xantrex reserves the right to use parts or products of original or improved design in the repair or replacement. If Xantrex repairs or replaces a product, its warranty continues for the remaining portion of the original Warranty Period or 90 days from the date of the return shipment to the customer, whichever is greater. All replaced products and all parts removed from repaired products become the property of Xantrex.

Xantrex covers both parts and labor necessary to repair the product, and return shipment to the customer via a Xantrex-selected non-expedited surface freight within the contiguous United States and Canada. Alaska, Hawaii and outside of the United States and Canada are excluded. Contact Xantrex Customer Service for details on freight policy for return shipments from excluded areas.

**How do you get service?** If your product requires troubleshooting or warranty service, contact your merchant. If you are unable to contact your merchant, or the merchant is unable to provide service, contact Xantrex directly at:

Telephone: +34 93 470 5330  
Fax: +34 93 473 6093  
Email: support.europe@xantrex.com  
Website: www.xantrex.com

Direct returns may be performed according to the Xantrex Return Material Authorization Policy described in your product manual. For some products, Xantrex maintains a network of regional Authorized Service Centers. Call Xantrex or check our website to see if your product can be repaired at one of these facilities.

**What proof of purchase is required?** In any warranty claim, dated proof of purchase must accompany the product and the product must not have been disassembled or modified without prior written authorization by Xantrex.

Proof of purchase may be in any one of the following forms:

- The dated purchase receipt from the original purchase of the product at point of sale to the end user; or
- The dated dealer invoice or purchase receipt showing original equipment manufacturer (OEM) status; or
- The dated invoice or purchase receipt showing the product exchanged under warranty.

**What does this warranty not cover?** Claims are limited to repair and replacement, or if in Xantrex's discretion that is not possible, reimbursement up to the purchase price paid for the product. Xantrex will be liable to you only for direct damages suffered by you and only up to a maximum amount equal to the purchase price of the product.

This Limited Warranty does not warrant uninterrupted or error-free operation of the product or cover normal wear and tear of the product or costs related to the removal, installation, or troubleshooting of the customer's electrical systems. This warranty does not apply to and Xantrex will not be responsible for any defect in or damage to:

- a) the product if it has been misused, neglected, improperly installed, physically damaged or altered, either internally or externally, or damaged from improper use or use in an unsuitable environment;
- b) the product if it has been subjected to fire, water, generalized corrosion, biological infestations, or input voltage that creates operating conditions beyond the maximum or minimum limits listed in the Xantrex product specifications including high input voltage from generators and lightning strikes;
- c) the product if repairs have been done to it other than by Xantrex or its authorized service centers (hereafter "ASCs");
- d) the product if it is used as a component part of a product expressly warranted by another manufacturer;
- e) the product if its original identification (trade-mark, serial number) markings have been defaced, altered, or removed;
- f) the product if it is located outside of the country where it was purchased; and
- g) any consequential losses that are attributable to the product losing power whether by product malfunction, installation error or misuse.

## Disclaimer

### Product

THIS LIMITED WARRANTY IS THE SOLE AND EXCLUSIVE WARRANTY PROVIDED BY XANTREX IN CONNECTION WITH YOUR XANTREX PRODUCT AND IS, WHERE PERMITTED BY LAW, IN LIEU OF ALL OTHER WARRANTIES, CONDITIONS, GUARANTEES, REPRESENTATIONS, OBLIGATIONS AND LIABILITIES, EXPRESS OR IMPLIED, STATUTORY OR OTHERWISE IN CONNECTION WITH THE PRODUCT, HOWEVER ARISING (WHETHER BY CONTRACT, TORT, NEGLIGENCE, PRINCIPLES OF MANUFACTURER'S LIABILITY, OPERATION OF LAW, CONDUCT, STATEMENT OR OTHERWISE), INCLUDING WITHOUT RESTRICTION ANY IMPLIED WARRANTY OR CONDITION OF QUALITY, MERCHANTABILITY OR FITNESS FOR A PARTICULAR PURPOSE. ANY IMPLIED WARRANTY OF MERCHANTABILITY OR FITNESS FOR A PARTICULAR PURPOSE TO THE EXTENT REQUIRED UNDER APPLICABLE LAW TO APPLY TO THE PRODUCT SHALL BE LIMITED IN DURATION TO THE PERIOD STIPULATED UNDER THIS LIMITED WARRANTY.

IN NO EVENT WILL XANTREX BE LIABLE FOR: (A) ANY SPECIAL, INDIRECT, INCIDENTAL OR CONSEQUENTIAL DAMAGES, INCLUDING LOST PROFITS, LOST REVENUES, FAILURE TO REALIZE EXPECTED SAVINGS, OR OTHER COMMERCIAL OR ECONOMIC LOSSES OF ANY KIND, EVEN IF XANTREX HAS BEEN ADVISED, OR HAD REASON TO KNOW, OF THE POSSIBILITY OF SUCH DAMAGE, (B) ANY LIABILITY ARISING IN TORT, WHETHER OR NOT ARISING OUT OF XANTREX'S NEGLIGENCE, AND ALL LOSSES OR DAMAGES TO ANY PROPERTY OR FOR ANY PERSONAL INJURY OR ECONOMIC LOSS OR DAMAGE CAUSED BY THE CONNECTION OF A PRODUCT TO ANY OTHER DEVICE OR SYSTEM, AND (C) ANY DAMAGE OR INJURY ARISING FROM OR AS A RESULT OF MISUSE OR ABUSE, OR THE INCORRECT INSTALLATION, INTEGRATION OR OPERATION OF THE PRODUCT.

IF YOU ARE A CONSUMER (RATHER THAN A PURCHASER OF THE PRODUCT IN THE COURSE OF A BUSINESS) AND PURCHASED THE PRODUCT IN A MEMBER STATE OF THE EUROPEAN UNION, THIS LIMITED WARRANTY SHALL BE SUBJECT TO YOUR STATUTORY RIGHTS AS A CONSUMER UNDER THE EUROPEAN UNION PRODUCT WARRANTY DIRECTIVE 1999/44/EC AND AS SUCH DIRECTIVE HAS BEEN IMPLEMENTED IN THE EUROPEAN UNION MEMBER STATE WHERE YOU PURCHASED THE PRODUCT. FURTHER, WHILE THIS LIMITED WARRANTY GIVES YOU SPECIFIC LEGAL RIGHTS, YOU MAY HAVE OTHER RIGHTS WHICH MAY VARY FROM EU MEMBER STATE TO EU MEMBER STATE OR, IF YOU DID NOT PURCHASE THE PRODUCT IN AN EU MEMBER STATE, IN THE COUNTRY YOU PURCHASED THE PRODUCT WHICH MAY VARY FROM COUNTRY TO COUNTRY AND JURISDICTION TO JURISDICTION.



---

## Return Material Authorization Policy

Before returning a product directly to Xantrex you must obtain a Return Material Authorization (RMA) number and the correct factory "Ship To" address. Products must also be shipped prepaid. Product shipments will be refused and returned at your expense if they are unauthorized, returned without an RMA number clearly marked on the outside of the shipping box, if they are shipped collect, or if they are shipped to the wrong location.

When you contact Xantrex to obtain service, please have your instruction manual ready for reference and be prepared to supply:

- The serial number of your product
- Information about the installation and use of the unit
- Information about the failure and/or reason for the return
- A copy of your dated proof of purchase

Record these details on page WA-4.

## Return Procedure

Package the unit safely, preferably using the original box and packing materials. Please ensure that your product is shipped fully insured in the original packaging or equivalent. This warranty will not apply where the product is damaged due to improper packaging.

Include the following:

- The RMA number supplied by Xantrex Technology Inc. clearly marked on the outside of the box.
- A return address where the unit can be shipped. Post office boxes are not acceptable.
- A contact telephone number where you can be reached during work hours.
- A brief description of the problem.

Ship the unit prepaid to the address provided by your Xantrex customer service representative.

**If you are returning a product from outside of the USA or Canada** In addition to the above, you **MUST** include return freight funds and are fully responsible for all documents, duties, tariffs, and deposits.

**If you are returning a product to a Xantrex Authorized Service Center (ASC)** A Xantrex return material authorization (RMA) number is not required. However, you must contact the ASC prior to returning the product or presenting the unit to verify any return procedures that may apply to that particular facility and that the ASC repairs this particular Xantrex product.

## Out of Warranty Service

If the warranty period for your product has expired, if the unit was damaged by misuse or incorrect installation, if other conditions of the warranty have not been met, or if no dated proof of purchase is available, your unit may be serviced or replaced for a flat fee.

To return your product for out of warranty service, contact Xantrex Customer Service for a Return Material Authorization (RMA) number and follow the other steps outlined in "Return Procedure" on page WA-3.

Payment options such as credit card or money order will be explained by the Customer Service Representative. In cases where the minimum flat fee does not apply, as with incomplete units or units with excessive damage, an additional fee will be charged. If applicable, you will be contacted by Customer Service once your unit has been received.

## Information About Your System

As soon as you open your XW Hybrid Inverter/Charger package, record the following information and be sure to keep your proof of purchase.

- Serial Number \_\_\_\_\_
- Product Number 865-1035, 865-1040, 865-1045
- Purchased From \_\_\_\_\_
- Purchase Date \_\_\_\_\_

If you need to contact Customer Service, please record the following details before calling. This information will help our representatives give you better service.

- Length of time inverter has been installed \_\_\_\_\_
- Battery/battery bank size \_\_\_\_\_
- Battery type (e.g. flooded, sealed gel cell, AGM) \_\_\_\_\_
- DC wiring size and length \_\_\_\_\_
- Alarm sounding? \_\_\_\_\_
- Description of indicators on front panel \_\_\_\_\_
- Appliances operating when problem occurred \_\_\_\_\_
- Description of problem \_\_\_\_\_

---

---

# Index

## Numerics

- 2-stage charge mode 3–11
- 3-stage charge mode 3–10

## A

- absorption charging stage 3–11
- AC settings menu
  - default settings B–4
  - description 3–15
- accessories A–7
- advanced features menu 3–29
- Advanced menu 3–4
- automatic faults 4–16
- automatic generator start 3–8
- auxiliary output menu
  - default settings B–6
  - description 3–21

## B

- basic features 1–2
- basic operation 1–3
- battery equalization 3–12
- battery level LEDs 2–6
- battery type 3–9
- bulk charging stage 3–11

## C

- charger block 3–10, 3–13
- charger settings menu
  - default settings B–3
  - description 3–9
- charger status LED 2–3
- charging cycle diagram 3–10
- connections menu
  - default settings B–6
  - description 3–27
- custom battery menu 3–14
  - default settings B–4
- Customer Service
  - preparing to call WA–4

## D

- default settings, restoring 3–29
- device home screen 2–11
- Down arrow button 2–7

## E

- electrical specifications A–2
- energy management features 3–17
- Enter button 2–7
- equalize button and LED 2–4
- equalize charging 3–12
- equalize mode 2–13
- escalating automatic faults 4–16
- Exit button 2–7

## F

- fault types 4–16
- fault/warning LED (Inverter Information Panel) 2–4
- fault/warning LED (System Control Panel) 2–7
- faults and warnings 4–10
- float charging stage 3–11

## G

- Gen (AC2) LED 2–2
- generator support 2–12
- generator support menu
  - default settings B–5
  - description 3–20
- Grid (AC1) LED 2–2
- grid support 2–13, 3–17
- grid support settings menu
  - default settings B–5
  - description 3–16

## H

- home screen 2–11

## I

- Information about Your System form WA–4
- inverter
  - purchase date WA–4
  - serial number WA–4
- Inverter Information Panel 1–6, 2–2
- inverter settings menu
  - default settings B–3
  - description 3–7
- inverter status LED 2–3
- islanding protection 1–5

## K

- keypress for system standby mode 2–8

## L

load shave 2–13, 3–16, 3–18

## M

manual faults 4–16  
mechanical specifications A–7  
menu map 3–6, B–2  
meters screen 2–13  
multi-stage charging process 3–10

## N

no float charging stage 3–11

## O

on/off button 2–5

## P

passthru 2–13  
peak load shaving 3–18  
Power Save 3–29  
proof of purchase WA–4  
purchase date WA–4

## Q

qualifying AC 2–12

## R

recharge volts 3–9  
restore default settings 3–29  
RPO 3–29

## S

SCP  
    device setup menus 2–10  
    features 1–7, 2–7  
    select device menu 2–10  
    system status screen 2–11  
search mode 2–13, 3–2, 3–7, 3–8  
sell mode 2–13, 3–16  
serial number WA–4  
specifications  
    electrical A–2  
    mechanical A–7  
standby 2–13  
standby button 2–7, 2–8  
state of charge LEDs 2–6  
surge performance 1–4  
System Control Panel. See SCP  
system home screen 2–9

system standby mode 2–8  
system status screen 2–11

## T

Three-Phase Configuration 3–25  
three-phase configuration 3–25  
three-stage charge mode 3–10  
Time-of-Use (TOU) metering 3–19  
troubleshooting  
    fault messages 4–15  
    general guidelines 4–2  
    motor loads 4–3  
    problem loads 4–3  
    resistive loads 4–3  
    warning messages 4–10  
two-stage charge mode 3–11

## U

Up arrow button 2–7

## W

warning  
    automatic 4–11  
    manual 4–11  
warranty  
    terms and conditions WA–1

## X

Xanbus 1–2  
Xantrex  
    web site iv  
XW Inverter/Charger home screen 2–11



**Xantrex Technology Inc.**

+34 93 470 5330 Tel direct  
+34 93 473 6093 Fax direct  
support.europe@xantrex.com  
www.xantrex.com