



SolrenView™

Web-Based Monitoring

SolrenView Indoor (residential)
SolrenView LCD (external)

INSTALLATION AND OPERATION GUIDE

Revision A

© 2010, Solectria Renewables LLC

TABLE OF CONTENTS

1.0	Data Monitoring System Overview	3
2.0	Monitoring Options.....	4
2.1	Revenue Grade Monitoring.....	4
2.2	Inverter Direct Monitoring.....	4
2.3	Weather Station	4
2.4	Kiosk View	4
3.0	Ordering Information	6
4.0	System Requirements	7
4.1	Wire/Cable Lengths.....	7
4.2	Site Preparation.....	7
5.0	Installing SolrenView.....	8
5.1	Inverter Direct Connections.....	8
5.2	Connecting multiple inverters.....	9
5.3	Revenue Grade Monitoring.....	9
5.4	Ethernet Connection	9
6.0	SolrenView Operation	10
6.1	Device Sensing.....	10
6.2	Internet connection.....	10
7.0	Web View	11
7.1	Web page information	11
7.2	Inverter Direct and Revenue Grade Displays	12
7.3	Inverter and Revenue Grade history data.....	12
8.0	Alarm/Event Notifications	13
9.0	Troubleshooting.....	14
9.1	Server Light not Flashing.....	14
9.2	Find the LAN IP address of the SolrenView Data Monitor.....	15
9.3	Setting a Static LAN IP Address	15
10.0	Warranty – Hardware Limited Warranty Policy.....	18
10.1	Warranty Start Date	18
10.2	Warranty Period	18
10.3	Scope of Warranty.....	18
10.4	Restrictions	19
10.5	Hardware Return Procedure	19
10.6	Service Information	20
10.7	Disclaimer	21
11.0	Appendices	23
	Appendix A – SolrenView Data Sheet.....	23
	Appendix B – Contact Information	23
	Appendix C – SolrenView™ Site Survey.....	23

For more help and inquiries, please contact Solectria Renewables (see [Appendix B – Contact Information](#)).

1.0 DATA MONITORING SYSTEM OVERVIEW

SolrenView™ monitoring is a state-of-the-art data acquisition system (DAS) and is designed to interpret the signals from Solectria Renewables inverters and/or revenue grade metering system and send the information to the Solectria Renewables server for display on the internet (<http://www.solrenview.com/>). This is a subscription service for a period of 3 or 5 years, renewable at prevailing rates. Data is saved to Solectria Renewable servers for the life of the subscription plan, and the inverters history may be viewed or downloaded in CSV format to export to excel for the site owner to chart. The SolrenView DAS collects real-time data samples from inverters and pulse meters at 1-minute intervals. The data is then sent over the Internet to the SolrenView server when a connection can be established. Data samples received by the server are retrieved by the web server whenever a user queries the information with a browser.

This manual is written for external mounted SolrenView DAS units only; for commercial inverters 10kW and larger with built in display panels. Please review the inverter manual for installation and connection details.

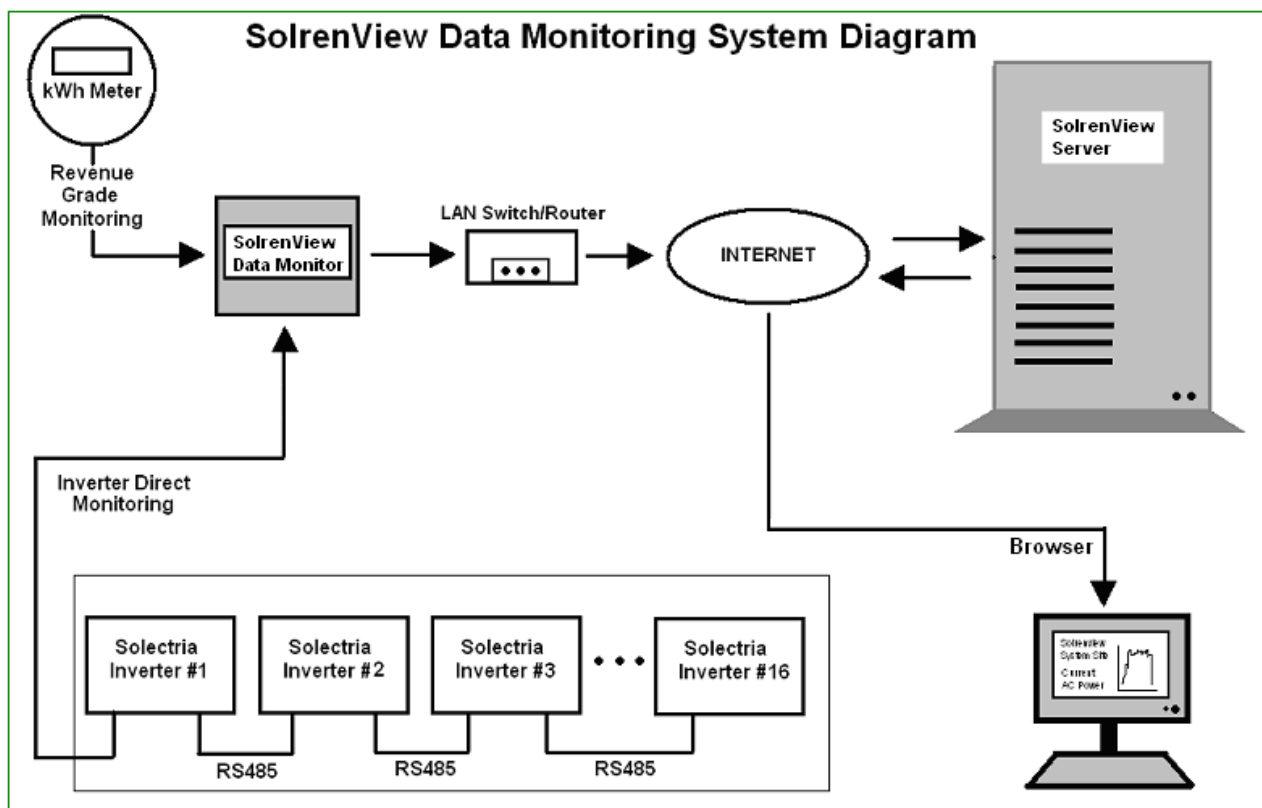

Figure 1.1 SolrenView over view

2.0 MONITORING OPTIONS

2.1 Revenue Grade Monitoring

The SolrenView DAS is connected to the pulse output of a KYZ meter or RS485 from a Veris meter (CT). The DAS keeps count of the meter-triggered pulses to provide the cumulative kWh value. Solectria Renewables may also report the revenue grade totals to certain agencies for net metering reimbursement; this is an additional *option* if a customer chooses. Any brand of inverter can provide revenue grade metering.

2.2 Inverter Direct Monitoring

The SolrenView DAS is directly connected to the RS485 line of one Solectria Renewables inverter. 15 additional Solectria Renewables inverters can be connected to the line with 'daisy-chain' cables. Each device connected must have a unique ID number between 1 and 16. In the example on the next page, inverter PV#1 is directly connected to the monitor, while subsequent inverters (PV#2 onwards) are connected in series to each other. Inverters 10kW and larger with built-in display units cannot be daisy-chained. Please refer to the inverter manual for instructions.

2.3 Weather Station

The real-time weather package allows a customer to use an internet connection to retrieve information about the operation of their PV system via www.solrenview.com. The crucial environmental information provided with this *option* is: irradiance, ambient temperature, module temperature, wind speed and wind direction. Please refer to the weather station manual for details about this product.

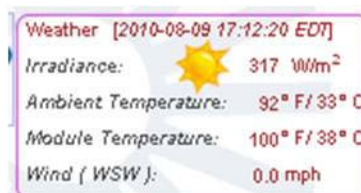

2.4 Kiosk View

The web view is enabled with flash to be shown on a local monitor, usually in a lobby or classroom. This will scroll through several different photos and site information (provided by the customer) and includes a short tutorial about solar. This *option* is available with either revenue grade or Inverter Direct monitoring package.

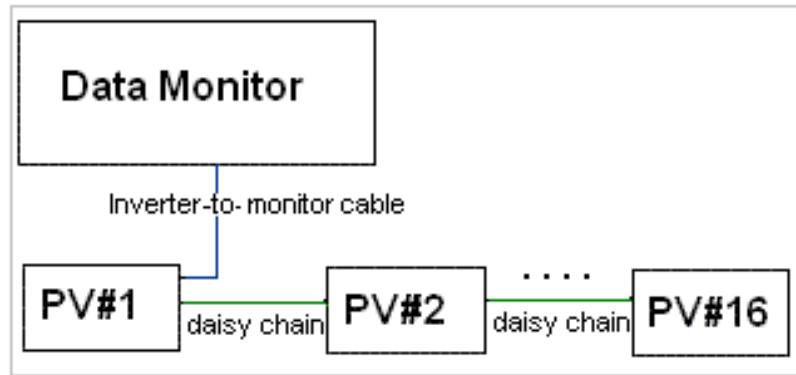

Figure 1.2 Inverter connections

A 6-foot inverter to SolrenView cable will be provided, as well as the inverter to inverter 'daisy-chain' cables to link two neighboring inverters together.

3.0 ORDERING INFORMATION

The SolrenView monitoring DAS is normally ordered through the solar system installer or distribution agent. Please contact one of our distributors for current pricing structure (please see: <http://www.solren.com/distributors.html> for a list of distributors). Monitoring contract renewals can be purchased directly from Solectria Renewables.

Solectria Renewables must program the SolrenView DAS for each installation. A site survey form must be completed and returned to Solectria Renewables prior to the shipment of the equipment (see [Appendix C – SolrenView™ Site Survey](#)).

The SolrenView DAS will ship with the electronic receiving and sending unit, power cable, cable from the unit to 1 inverter and if multiple inverters are monitoring daisy-chain cables for interconnections. For outdoor installations, weatherproof housing is required (this is optional if indoor installation).

4.0 SYSTEM REQUIREMENTS

To send the information to Solectria Renewables server, the SolrenView DAS requires a high speed internet connection. A CAT5 Ethernet cable connects the DAS to a router or other LAN device capable of providing an IP address. The WAN connects to an internet equipped device.

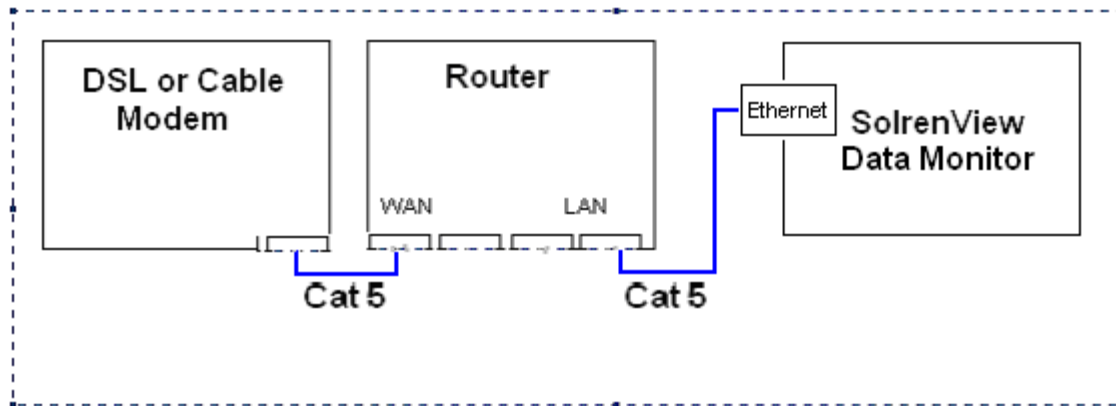

Figure 2.1 LAN configuration

4.1 Wire/Cable Lengths

The total wiring distance between two final endpoints of a network must not exceed 100 meters (328 ft). This rule applies to both the Ethernet (wire length from DAS to router/switch/modem) and RS485 (wire length from DAS to the last inverter of a daisy-chain) networks. The wires from the KYZ meter pulse outputs to the data monitor must not exceed 100 ft.

4.2 Site Preparation

The SolrenView DAS is designed for wall mounting and should be installed in an indoor location close to the inverter(s). A standard 120VAC outlet for the DAS power supply is required the power supply cable is 6 feet. For outdoor installations, weatherproof housing is required (this is optional if indoor installation).

5.0 INSTALLING SOLREVIEW

It is recommended to install the SolrenView DAS module and attach all wiring prior to applying the power to the DAS.

5.1 Inverter Direct Connections

For one inverter, connect the RJ45 connector to the appropriate port inverter and the bare wire connections labeled A and B to the RS485A and RS485B connections on the SolrenView DAS.

For Inverter Models PVI1800 and PVI2500, the brown wire is to the RS485A and the Brown/white wire is to RS485B. For the PVI3000, PVI4000, PVI5000 and PVI 5300, the brown wire is the RS485A and the green wire is the RS485B.

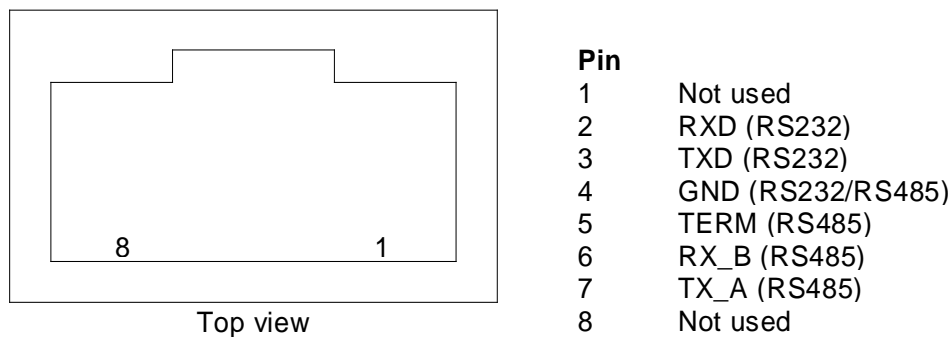

Figure 4.1 PVI1800 and PVI2500 RS485 connections

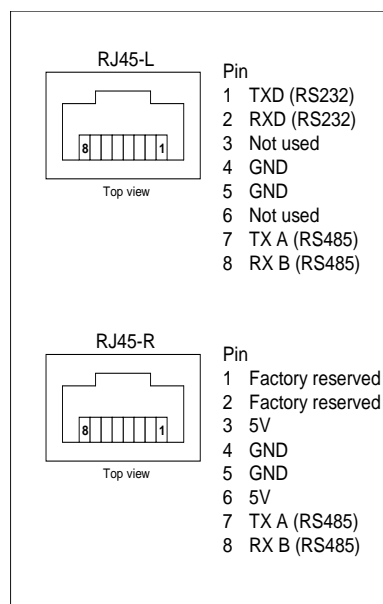

Figure 4.2 PVI3000 through PVI5300 RS485 connections

5.2 Connecting multiple inverters

Multiple inverters are connected from one to another using the cables supplied. If the distances between the inverters are greater than the standard cables, CAT5 cables may be used. If mixing PVI1800 or PVI2500 with any PVI3000-PVI5300, a hybrid cable must be used as the pin configurations are different. Up to 16 inverters may be connected to one SolrenView DAS. Each inverter must have a unique ID number between 1 and 16. If you received inverters with the same ID numbers, please contact Solectria Renewables for assistance (see [Appendix B – Contact Information](#)).

5.3 Revenue Grade Monitoring

A pulse type revenue grade meter is installed into the AC wiring between the inverter and the grid (please follow applicable codes). The following meters have been configured for use with the SolrenView DAS:

- For 3 phase AC service GE KV2c meter
- For single phase AC service the ABB FM2S

When installing the pulse meter, verify the inverter(s) AC line is wired to the top lugs (line) of the meter base and the building/utility is wired to the bottom lugs (load) of the meter base to enable correct forward counting. Connect pulse output of KYZ meter to the DAS. The Red wire to 'K', Yellow wire to 'Y1', in some instance the Black to 'Z1' to the terminal blocks on the SolrenView DAS. Extend pulse wires up to 100' as needed.

The Veris meter "current transducer" (CT's) is installed on 3-phase AC service. Connect to the DAS using the RS485 connections with the + from the meter to the RS485A and the – from the meter to the RS485B.

5.4 Ethernet Connection

With the SolrenView DAS installed and the inverter and/or revenue grade meter attached, the Ethernet cable can be attached to the Ethernet port. The SolrenView DAS can now have the power applied using the supplied AC adapter. The SolrenView DAS will perform a self test and can be verified by the power light, server light and device light all turn on and off twice. Once there is network activity, the LED's near the Ethernet port on the data monitor will blink.

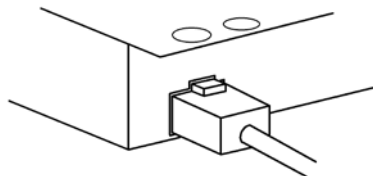

****Note: Blinking of the LEDs on the Ethernet port (green, orange) only indicates the existence of a physical connection. This does not guarantee that a successful outbound network connection if the logical IP configuration (DHCP or LAN gateway, etc) has not been configured properly.**

6.0 SOLREVIEW OPERATION

6.1 Device Sensing

When power is applied to the SolrenView DAS, the unit will poll the connected devices for information once per minute. This can be verified as the device light will blink once per device every 60 seconds. For example, if there are 2 inverters, the device light will blink twice each minute. If there are 3 inverters and one revenue grade meter, the device light will blink 4 times. While the inverters are off they will not be recognized by the SolrenView DAS.

6.2 Internet connection

Following the device light blink indicating collecting the information from the devices, the server light will blink once to indicate the information has been sent to the internet for transmission to the Solectria Renewables server. If the server light does not blink, this is an indication the DAS does not have access to the internet (see troubleshooting).

7.0 WEB VIEW

Using any web enabled device the SolrenView site can be viewed via a direct a browser to: <http://www.solrenview.com>. Click on 'Live Sites' at the top of the page and a list of public system sites will be displayed sorted by installer. If your site isn't listed yet, please call to check Solectria Renewables (see Appendix B) on the status of your site's availability.

7.1 Web page information

Solectria Renewables designates several status indications as a quick visual for the site:

Status Indications

- Active** System is active (inverter/meter communicating)
- Asleep** System is not currently active, ie at night or during low sunlight levels
- Inactive** System has been asleep for almost a day
- Offline** System is not currently connected to the SolrenView server

During normal daylight hours the status indication should be green and "active" The top line indicates the DAS is online and the last update time stamp. The server will update the view every 15 minutes. For kiosk view, the server will update at each full cycle.

Example of system status'

Online [last update: 2008-09-10 00:28:15 EDT]		Online [last update: 2008-09-10 00:28:15 EDT]	
System Status, <u>Inverter-Direct</u> :	Active	System Status, <u>Inverter-Direct</u> :	Inactive
Energy generated today:	0.0 kWh	Energy generated today:	0.0 kWh
Lifetime energy generated:	0.0 kWh	Lifetime energy generated:	0.0 kWh
Lifetime CO ₂ emission offset:	0.0 lbs	Lifetime CO ₂ emission offset:	0.0 lbs
System AC power now:	0.0 W	System AC power now:	0.0 W
View Inverter Direct		View Inverter-Direct	

An inactive status indication is the result of the inverter(s) not communicating or the revenue grade meter not communicating.

7.2 Inverter Direct and Revenue Grade Displays

On the summary page, if Revenue Grade monitoring is selected as an option, the data shown under 'Current System Status' is calculated from the Revenue Grade meter.

System Status Now [2009-03-12 14:13:46 EDT]

Online [last update: **2009-03-12 14:13:19 EDT**]

System Status, Revenue-Grade : Active

Energy generated today: **30.4** kWh

Lifetime energy generated: **5407.8** kWh

Lifetime CO₂ emission offset: **6760** lbs

System AC power now: **7740.0** W

[View Revenue-Grade](#)

If Revenue Grade monitoring is not selected, the system summary data is calculated from Inverter Direct data instead.

System Status Now [2009-03-12 14:14:29 EDT]

Online [last update: **2009-03-12 14:12:35 EDT**]

System Status, Inverter-Direct : Active

Energy generated today: **10.3** kWh

Lifetime energy generated: **535.3** kWh

Lifetime CO₂ emission offset: **669** lbs

System AC power now: **2717.0** W

[View Inverter-Direct](#)

7.3 Inverter and Revenue Grade history data

To view logged data history, click on 'View Inverter Direct' or 'View Revenue Grade' link. The data log navigator is on the top left of the page.

[Day](#) [Week](#) [Month](#)

<< < > >>

The day mode (default) will show the current day view. To move back one day select the single back arrow < to go back to the first day select the double back arrow <<. To return to the current day, select the forward arrow > or double forward arrow >>. By selecting week or month, the view will change accordingly. The back and forward arrows will step back either one week at each selection or one month.

On the top right, a list of data values can be selected for viewing.

[AC Energy](#) [AC Power](#) [AC Voltage](#) [AC Current](#) [DC Voltage](#)

8.0 ALARM/EVENT NOTIFICATIONS

To be notified of system-related events, be sure to specify an e-mail address under the site survey/PO checklist. To get notification through SMS, the 10-digit phone number and service provider must be provided. For example: 978-123-1234 (T-Mobile)

Table of Supported Events:

Alarm/Event	DAS Unit	PV11800-2500	PV13000-5300	PV113/15kW	PV160/82/95kW	Description	Clears when	Severity Levels	Action Recommended
System- Offline	x					Data monitor not communicating to server	Network communication resumes	Informative	Check ethernet connection to DAS, power supply, router. Reboot the DAS
System- Inactive	x					Inverters, meters not communicating to Data Monitor	Devices communicate again	Informative	The inverter(s) may be off, check wiring to DAS
Inverter- Inactive		x	x	x	x	Inverter not communicating, triggered if 'System-Inactive' isn't	Inverter communicates	Informative	The inverter(s) may be off, check wiring to DAS
Inverter- Fan Life reached				x	x	Fan hours>40000; Trigger bit set by inverter	Inverter trigger bit clears	Warning	Replace fan
Inverter- MOV Fault			x	x	x	MOV Fault; Trigger bit set by inverter	Inverter trigger bit clears	Warning	The inverter may have had a high voltage event. MOV may need replacement
Inverter- AC Voltage Too High		x	x	x	x	AC Voltage Too High; Trigger bit set by inverter	Inverter trigger bit clears	Informative	Verify the grid conditions
Inverter- AC Voltage Too Low		x	x	x	x	AC Voltage Too Low; Trigger bit set by inverter	Inverter trigger bit clears	Informative	Verify the grid conditions
Inverter- AC Frequency Too High		x	x	x	x	AC Frequency Too High; Trigger bit set by inverter	Inverter trigger bit clears	Informative	Verify the grid conditions
Inverter- AC Frequency Too Low		x	x	x	x	AC Frequency Too Low; Trigger bit set by inverter	Inverter trigger bit clears	Informative	Verify the grid conditions
Inverter- Ground Fault		x	x	x	x	Ground Fault; Trigger bit set by inverter	Inverter trigger bit clears	Critical	Check the array for ground fault
Inverter- DC Voltage Too High		x	x	x	x	DC Voltage Too High; Trigger bit set by inverter	Inverter trigger bit clears	Critical	Remove DC voltage from inverter
Inverter- Hardware Error		x	x	x	x	Hardware Error; Trigger bit set by inverter	Inverter trigger bit clears	Critical	Contact Solectria Renewables

9.0 TROUBLESHOOTING

<u>Fault Condition</u>	<u>Possible Cause</u>	<u>Possible Solutions</u>
No power light	No power to the DAS	<ol style="list-style-type: none"> 1. Verify power cable is plugged in to an outlet. 2. Verify the outlet has proper voltage. 3. Check VDC voltage at the DAS, If not present replace the power cable. 4. Replace the DAS. 5. Contact Solectria Renewables.
Device light not flashing	The DAS is not detecting any devices	<ol style="list-style-type: none"> 1. If Inverter Direct, verify inverter connections to RS485 A and B. 2. Verify the inverter ID number is between 1 and 16. 3. If multiple inverters installed, verify the ID numbers are not duplicated. Check daisy-chain cables. 4. If revenue grade option, verify the pulse meter is connected to Y1 and K, CT meter to RS485 A and B.
Server light not flashing	The DAS is not sending to the internet	<ol style="list-style-type: none"> 1. The DAS is not receiving an IP address from the router. 2. The CAT5 Ethernet cable is not attached or defective. 3. The router is not allowing the DAS traffic through. 4. A firewall is blocking the outgoing port. 5. There is an IP address conflict.

9.1 Server Light not Flashing

If the SolrenView DAS is not connecting to the internet, verify the “server” light is flashing at least once per minute. If not flashing and the SolrenView is configured with DHCP “dynamic host configuration protocol”, it may have temporarily lost the connection and has selected the “fall back” IP address of 192.168.1.11, and this IP address is not compatible with your LAN. Using a browser window, enter the LAN IP address to see if the router can communicate with the DAS. The Ethernet cable must be attached prior to powering up the DAS.

If available, use a DHCP-enabled router or temporarily enable DHCP on an existing router to find the IP address of the data monitor by following these steps:

9.2 Find the LAN IP address of the SolrenView Data Monitor

Access and view the DHCP client list of your local DHCP server. Refer to your network admin and/or router manual for help. If the DHCP server is your router, open a web page to the router, usually <http://192.168.1.1> to find the DHCP client list. The serial number of the SolrenView DAS is the MAC address. Locate this number to compare with the DHCP client list. The MAC address format is 00:90:c2:XX-XX-XX.

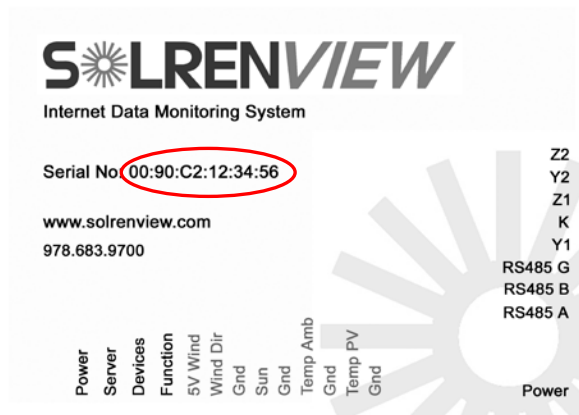

The IP address of the data monitor should be displayed in the client entry.

Example DHCP client list

DHCP Active IP Table					Refresh
DHCP Server IP Address: 192.168.1.1					
Client Hostname	IP Address	MAC Address	Interface	Delete	
00:90:c2:12:34:56	192.168.1.100	00-90-c2-12-34-56	Ethernet	<input type="checkbox"/>	
computer1	192.168.1.101	xx-xx-xx-xx-xx-xx	Ethernet	<input type="checkbox"/>	

If the DHCP router drops the SolrenView DAS, or if there are address conflicts, it is recommended to set the DAS to a Static or fixed IP address. This can only be accomplished if you have the current LAN IP address and have a computer connected to the same network.

9.3 Setting a Static LAN IP Address

SolrenView DAS units shipping DHCP enabled have a "fall back" IP address of **192.168.1.11** and a subnet mask of **255.255.255.0**, the default gateway is **0.0.0.0** in the event that DHCP fails during start-up. Use a switch, hub, router, and/or crossover cable to connect to this IP address via a web browser in order to reconfigure its IP settings. After entering the IP address, click on the settings tab.

00:90:c2:d8:09:f9
 C20090817.bin
 [Aug 17 2009:14:33:46]

current time: 2009-08-17 15:27:07 DST
 start time: 2009-08-17 17:54:38

COMMERCIAL

[Main](#) [Settings](#)

Data Polling Interval: 10 secs

Meter Count: 1234 * 0/1000=0 kWh

Device(s) found: 1 RS485#2:[2009-08-17 15:27:03] PV System Power: 0.0 W PV Total Energy: 1000.0 kWh

ID	Baud Rate	Sn#	Class	DC Volt (V)	VAB (V)	VBC (V)	VCA (V)	AC Current (A)	AC Power (W)	AC Energy (kWh)	RT (hrs)	Phase Seq	GF Alarm/Code1 msb	DC Stat/Code1 lsb	DC Limit/Code2 msb	DC HW Fail/Code2 lsb	AC Status/Code3 msb	AC Limit/Code3 lsb	AC HW Fail/Code4 msb	Error/Code4 lsb
1	19200	080000-00	PVI 60-95kW	265.0	0.0	0.0	0.0	0.0	0.0	1000.0	0	0	00h	44h	00h	00h	00h	00h	00h	01h

Token	WAC	VAC	Volt High	Volt Very High	Volt Low	Volt Very Low	Freq High	Freq Low	Freq Very Low	Clear Volt High	Clear Volt Low	Clear Freq Low
A88	95000	480	514.88	528.07	421.85	479.02	60.50	57.81	56.98	1000	2000	2000

Eac: 1000 kWh
 Pac: 0 W

Browser window DAS view

1. Click the settings tab to open the page for setting the static IP address.

00:90:c2:d8:09:f9
 C20090817.bin
 [Aug 17 2009:14:33:46]

current time: 2009-08-17 15:29:07 DST
 start time: 2009-08-17 17:54:38

COMMERCIAL

[Main](#) [Settings](#)

Reboot

Time Synchronization	Network Configuration
Last NIST Update [N/A] <input type="button" value="Update"/> Disable DST <input type="checkbox"/> NIST Server:Port <input type="text" value="129.6.15.29"/> : <input type="text" value="13"/> Standard UTC Offset <input type="text" value="-5"/>	Currently Configured MAC 00:90:c2:d8:09:f9 DHCP On IP 192.168.44.50 Netmask: 255.255.255.0 Router/Gateway 192.168.44.1 Last Update N/A
Miscellaneous Baud Rate <input checked="" type="radio"/> Default <input type="radio"/> 19200 only <input type="radio"/> 9600 only Pulse Weight (WH) <input type="text" value="0"/> Inverter ID <input type="text" value="1"/> Baud Rate <input checked="" type="radio"/> 19200 <input type="radio"/> 9600 Inverter Low Voltage Tap <input checked="" type="radio"/> 0% <input type="radio"/> -5% <input type="radio"/> -10%	Use DHCP <input checked="" type="checkbox"/> IP (Non-DHCP) <input type="text" value="192.168.1.11"/> Router/Gateway <input type="text" value="192.168.44.1"/> Netmask <input type="text" value="255.255.255.0"/> Data Server:Port <input type="text" value="74.208.71.243"/> : <input type="text" value="1236"/>
<input type="button" value="Submit"/> <input type="button" value="Cancel"/>	<input type="button" value="Submit"/> <input type="button" value="Cancel"/>

2. Un-check the Use DHCP box.

current time: 2009-08-17 15:22:07 DST
start time: 2009-08-17 17:54:38

Reboot

Network Configuration

Currently Configured	
MAC	00:90:c2:d8:09:f9
DHCP	On
IP	192.168.44.50
Netmask	255.255.255.0
Router/Gateway	192.168.44.1
Last Update	N/A

Use DHCP

IP (Non-DHCP)

Router/Gateway

Netmask

Data Server:Port :

3. Enter the LAN IP address, router gateway and netmask. Make sure these numbers match the exact numbers for the server or router LAN. If they are not correct the DAS will not connect to the internet.
4. Press submit at the bottom of the page. If the IP address is different from the address typed into the browser window, it will not reopen. To verify the settings, please type the new static IP address into the browser window.
5. Verify the server light flashes at least once per minute.

10.0 WARRANTY – HARDWARE LIMITED WARRANTY POLICY

10.1 Warranty Start Date

“Start Date” shall mean the earlier of (a) the date that data is first reported by end user to <http://www.solrenview.com> or (b) 30 days after Solectria Renewables’ invoice for product.

10.2 Warranty Period

10.2.1 External SolrenView gateways

SolrenView gateways, (except weather monitoring gateways), shall have a warranty of three (3) years from the Start Date if the customer has purchased a three (3) year monitoring package, or five (5) years from the Start Date if the customer has purchased a five (5) year monitoring package. Similarly, if extended year monitoring has been purchased, Solectria Renewables will warrant gateway hardware for the appropriate monitoring period.

10.2.2 SolrenView Weather & Weather with Wind gateways

Solectria Renewables warranties gateways with SolrenView Weather monitoring for a period of one (1) year from Start Date.

10.2.3 SolrenView 3rd Party Hardware

All 3rd party hardware, including meters, light sensor, wind direction sensor, temp sensors shall have a 1 year pass-through warranty as provided by the original equipment manufacturer

10.3 Scope of Warranty

During the warranty period, Solectria Renewables warrants that the product shall be free from defects in materials and workmanship under normal authorized use consistent with product installation and use guides. If Solectria Renewables repairs or replaces a product, its warranty continues for the remaining portion of the original Warranty Period or 90 days from the date of the return shipment to the customer, whichever is greater. All warranties are null and void if full payment for products and associated shipping are not received in full and in a timely manner by Solectria Renewables.

Solectria Renewables will, at its option, repair or replace the defective product free of charge, provided that Solectria Renewables is notified of the product defect within the product’s Warranty Period, and provided that Solectria Renewables, through inspection, establishes the existence of such a defect and that it is covered by the Limited Warranty. Solectria Renewables will, at its option, use new and/or reconditioned parts in performing warranty repair and building replacement products. Solectria Renewables reserves the right to use parts or products of original or improved design in the repair or replacement. All replaced products and all parts removed from repaired products become the property of Solectria Renewables. Solectria Renewables will attempt to repair the unit within a reasonable time period - typically within a 20-business day

turnaround from date of receipt of the product by Solectria Renewables. Actual delivery times may vary depending on location. Solectria Renewables does not reimburse for lost energy production.

Solectria Renewables covers both parts and labor necessary to repair the product, and return shipment to the customer via a Solectria Renewables-selected non-expedited surface freight within the contiguous United States and Canada. Alaska, Hawaii and the Rest of The World are excluded. Contact Solectria Renewables customer service for details on freight policy for return shipments outside of the contiguous United States and Canada.

10.4 Restrictions

Solectria Renewables Limited Warranties do not cover normal wear and tear of the product or costs related to the labor, installation, removal, temporary power or any other expenses in connection with repair or replacement. These warranties do not apply to and Solectria Renewables will not be responsible for any defect in or damage to:

- a) The product if it has been misused, neglected, improperly installed, physically damaged or altered either internally or externally, or damage from improper use or use in an unsuitable environment;
- b) The product if it has been subjected to fire, water, generalized corrosion, biological infestations, acts of God or input voltage that creates operating conditions beyond the maximum or minimum limits listed in the Solectria Renewables product specifications including high input voltage from generators and lightning strikes;
- c) The product, if repairs have been performed by Solectria Renewables; unless authorized in writing by Solectria Renewables.
- d) The product, if it is used as a component part of a product expressly warranted by another manufacturer;
- e) The product if its original identification (trademark, serial number) markings have been defaced, altered, or removed;
- f) The product if it has been damaged in shipping;
- g) Any installation and operation beyond the scope covered by relevant safety regulations.

10.5 Hardware Return Procedure

If your product requires troubleshooting or warranty service, contact Solectria Renewables customer service (continued on next page).

Before returning any product directly to Solectria Renewables, you must obtain a Return Material Authorization (RMA) number and the correct factory "Ship To" address. Products must also be shipped prepaid. Product shipments will be refused and returned at your expense if they are not authorized, returned without an RMA number clearly marked on the outside of the shipping box, if they are shipped collect, or if they are shipped to the wrong location.

10.6 Service Information

10.6.1 Service Request

When you *request service*, Solectria Renewables will require the following information:

- 1) The model name and serial number of your product;
- 2) Information about the installation and use of the unit;
- 3) Information about the failure and/or reason for the return;
- 4) A copy of your dated proof of purchase.

10.6.2 Warranty Claim

In any *warranty claim*, dated proof of purchase must accompany the product and the product must not have been disassembled or modified without prior written authorization by Solectria Renewables.

Proof of purchase may be in any one of the following forms:

- 1) The dated purchase receipt from the original purchase of the product at point of sale to the end user, or
- 2) The dated merchant invoice or purchase receipt showing original equipment manufacturer (OEM) status, or
- 3) The dated invoice or purchase receipt showing the product exchanged under warranty.

10.6.3 Replacement Unit

Solectria Renewables will send a replacement unit if it is determined that the customer needs a replacement unit in advance of a repair of defective product (shipping cost covered by Solectria Renewables). The defective unit must be returned in the same packaging that the replacement unit was sent in.

10.6.4 Returning the Failed Unit

The failed unit **MUST** be returned to Solectria Renewables; it should **NOT** be opened or altered. The failed unit must be shipped back to Solectria Renewables via prepaid freight. If the failed unit is not received by Solectria Renewables within 30 days of customer's receipt of a replacement unit, the customer will be required to pay for the replacement unit.

10.6.5 Shipping

Solectria Renewables will ship replacement products prepaid to customer.

Preparing the Product for Shipping:

- 1) Package the unit safely, preferably using the original box and packing materials. Ensure that your product is shipped fully insured in the original packaging or equivalent. This warranty will not apply where the product is damaged due to improper packaging. See section above regarding obtaining service for procedure when Solectria Renewables sends a replacement unit in advance of defective material return.
- 2) Include the following:
 - a. The RMA number supplied by Solectria Renewables, LLC clearly marked on the outside of the box;
 - b. A return address to which the unit can be shipped. Post office boxes are not acceptable;
 - c. A contact telephone number where you can be reached during work;
 - d. A brief description of the problem;Ship the unit prepaid to the address provided by your Solectria Renewables customer service representative.

Returning a product from outside of the USA or Canada:

In addition to the above, you **MUST** include return freight funds and are fully responsible for all documents, duties, tariffs, and deposits.

10.7 Disclaimer

SOLECTRIA RENEWABLES LIMITED WARRANTIES ARE THE SOLE AND EXCLUSIVE WARRANTY PROVIDED BY SOLECTRIA RENEWABLES IN CONNECTION WITH YOUR SOLECTRIA RENEWABLES PRODUCT AND ARE, WHERE PERMITTED BY LAW, IN LIEU OF ALL OTHER WARRANTIES, CONDITIONS, GUARANTEES, REPRESENTATIONS, OBLIGATIONS AND LIABILITIES, EXPRESS OR IMPLIED, STATUTORY OR OTHERWISE IN CONNECTION WITH THE PRODUCT, HOWEVER ARISING (WHETHER BY CONTRACT, TORT, NEGLIGENCE, PRINCIPLES OF MANUFACTURER'S LIABILITY, OPERATION OF LAW, CONDUCT, STATEMENT OR OTHERWISE), INCLUDING WITHOUT RESTRICTION ANY IMPLIED WARRANTY OR CONDITION OF QUALITY, MERCHANTABILITY OR FITNESS FOR A PARTICULAR PURPOSE. ANY IMPLIED WARRANTY OF MERCHANTABILITY OR FITNESS FOR A PARTICULAR PURPOSE TO THE EXTENT REQUIRED UNDER APPLICABLE LAW TO APPLY TO THE PRODUCT SHALL BE LIMITED IN DURATION TO THE PERIOD STIPULATED UNDER THIS LIMITED WARRANTY.

IN NO EVENT WILL SOLECTRIA RENEWABLES, LLC, INCLUDING ITS SUPPLIERS, MANUFACTURERS, VENDORS, SUBCONTRACTORS, DISTRIBUTORS, DEALERS AND ANY OTHER AFFILIATES BE LIABLE FOR ANY SPECIAL, DIRECT, INDIRECT, INCIDENTAL OR CONSEQUENTIAL DAMAGES, LOSSES, COSTS OR EXPENSES HOWEVER ARISING WHETHER IN CONTRACT OR TORT INCLUDING WITHOUT RESTRICTION ANY ECONOMIC LOSSES OF ANY KIND, ANY LOSS OR DAMAGE TO PROPERTY, ANY PERSONAL INJURY, ANY DAMAGE OR INJURY ARISING FROM OR AS A RESULT OF ANY USE, MISUSE OR ABUSE, OR THE (IN-) CORRECT INSTALLATION, INTEGRATION OR OPERATION OF THE PRODUCT.

SOLECTRIA RENEWABLES NEITHER ASSUMES NOR AUTHORIZES ANY OTHER PERSON TO ASSUME FOR IT ANY OTHER LIABILITY IN CONNECTION WITH THE REPAIR OR REPLACEMENT OR THE PRODUCT.

10.8 Limitation of Liability

If your product is a consumer product, federal law does not allow an exclusion of implied warranties. To the extent you are entitled to implied warranties under federal law, to the extent permitted by applicable law they are limited to the duration of this Limited Warranty. Some states and provinces do not allow limitations or exclusions on implied warranties or on the duration of an implied warranty or on the limitation or exclusion of incidental or consequential damages, so the above limitation(s) or exclusion(s) may not apply to you. This Limited Warranty gives you specific legal rights. You may have other rights, which may vary from state to state or province to province.

WITHOUT LIMITING THE GENERALITY OF THE FOREGOING, UNLESS SPECIFICALLY AGREED TO BY IT IN WRITING, SOLECTRIA RENEWABLES

- 1) MAKES NO WARRANTY AS TO THE ACCURACY, SUFFICIENCY OR SUITABILITY OF ANY TECHNICAL OR OTHER INFORMATION PROVIDED IN MANUALS OR OTHER DOCUMENTATION PROVIDED BY IT IN CONNECTION WITH THE PRODUCT; AND
- 2) ASSUMES NO RESPONSIBILITY OR LIABILITY FOR LOSSES, DAMAGES, COSTS OR EXPENSES, WHETHER SPECIAL, DIRECT, INDIRECT, CONSEQUENTIAL OR INCIDENTAL, WHICH MIGHT ARISE OUT OF THE USE OF SUCH INFORMATION.

THE USE OF ANY SUCH INFORMATION WILL BE ENTIRELY AT THE USER'S RISK.

10.9 WARNING: LIMITATIONS ON USE

Please refer to your product user manual for limitations on uses of the product. Specifically, please note that Solectria Renewables products are not intended for use in connection with life support systems and Solectria Renewables makes no warranty or representation in connection with any use of the product for such purposes.

11.0 APPENDICES

Appendix A – SolrenView Data Sheet

http://solren.com/downloads/SolrenView_Datasheet.pdf

Appendix B – Contact Information

Solectria Renewables LLC
360 Merrimack Street
Building 9, 2nd floor
Lawrence, Massachusetts 01843
USA

Tel: 978.683.9700
Fax: 978.683.9702
Sales/ general info: inverters@solren.com
Customer Support: service@solren.com
Website: www.solren.com

Appendix C – SolrenView™ Site Survey

In order to have enough information to customize a web site and enable data monitoring, the site survey must be filled and turned in *before the data monitor is shipped*. The site survey may be downloaded here: [SolrenView Site Survey](#) Please submit the survey with the purchase order for the SolrenView monitoring or email to inverters@solren.com.

Contact information

Please provide contact information in the event we have questions about the site. We will also need the site name and address. For residential installations the street address can be omitted.

Email for Event Notifications

Provide email address for notifications.

Inverter Direct, Revenue Grade and Agency Reporting

Please select options here and on the purchase order. If revenue grade please let us know the agency for the reporting.

SolrenView LAN Configuration

DHCP mode Yes or No, if NO you must provide the LAN IP address, router gateway and subnet mask.

Hardware Details

If inverters have not yet arrived, you can leave this blank. If the inverters are on site please add serial number(s).

sales@solren.com www.solren.com www.solrenview.com
Boston (HQ): 978-683-9700 Fax: 978-683-9702
Los Angeles: 562-608-8913



Solectria Renewables Solreview Order Form

Installer Contact Info	
Company:	Contact Person:
Website:	Phone #:
	Email:
Email for Event Notifications:	

Installation Site Details	
Site Title:	Time Zone:
Street Address:	Expected Install Date:
City, State, Zip Code:	

Inverter Direct Monitoring:
Revenue Grade Monitoring:
Revenue Grade Agency Reporting:

SolrenView LAN Configuration (please consult with local IT personnel, do not leave blank!)
Use DHCP:
Static IP (Non-DHCP):
Default Gateway/Router IP:
Netmask:
IT/Network Administrator Contact:

Hardware Details	
VAC:	
Inverter model:	# of Inverters:
Serial Numbers:	
Module Type:	
# of modules:	
SolrenView MAC address:	