

KANEKA Thin Film PV
Installation Manual

MODULE TYPE: G-SA060

KANEKA CORPORATION





3-2-4, NAKANOSHIMA, KITA-KU







OSAKA 530-8288, JAPAN

reference No. G-SA060.002

Warning

Meaning of signs

	Not Allowed		No Disassembly		No Touching
	Procedures Must be Followed.			Beware of Electric Shock	

<p>Do not disassemble Kaneka thin-film silicon photovoltaic module(s) (hereinafter referred to as the MODULE(S)), as this may cause fire, electric shock, and injury.</p> 	<p>Do not shock the MODULES (e.g. by stepping on it), as this may break the glass part and cause malfunction, electric shock and injury.</p> 
<p>Follow the procedure in this manual when installing the MODULE and its platform.</p> 	<p>Beware of electric shock and short-circuit, as the MODULE generates high-tension current when exposed to light.</p> 
<p>Wear a safety belt, protection footwear, and protection gloves when installing the MODULE to prevent falling and electric shock. (Install safety fence and scaffolding to prevent falling.)</p> 	<p>The platform, connection box, and the inverter (power conditioner) must be grounded based on the regulation about grounding method.</p> 
<p>Do not expose the MODULE to the artificially concentrated sunlight.</p> 	

1. Dimensions

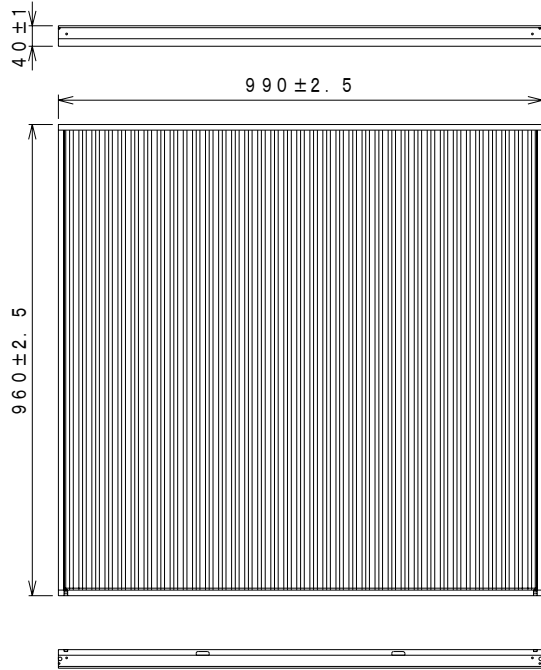

Front View

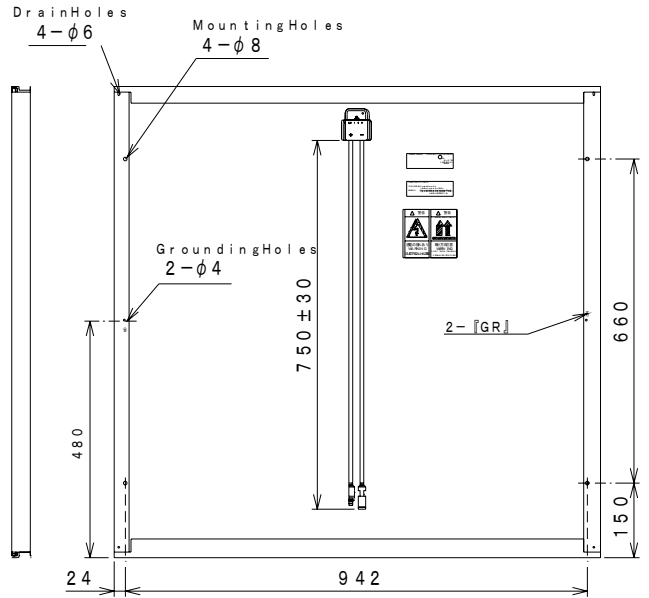

Back View

Weight : 13.7KG/pcs.

△				3RD ANGLE PROJECTION	SCALE	UNITS	USER
△				DATE	2004.06.11	1:10	mm
△				DRW		CHK	
△	05.03.24+LABEL					NAKAJIMA	DS-GSA
△	DATE	REVISION	DRW				

2. Electrical Characteristics of MODULES

PRODUCT : THIN-FILM SILICON PV MODULE			
MODEL: G-SA060	DATE: April 01, 2006		
SPECIFICATION LISTS	UNIT	VALUE	REMARK
Performance at STC (stabilized)			Tolerance: ±10%
Nominal Power (Pmax)	W	60.0	
Open Circuit Voltage (Voc)	V	92.0	
Open circuit Voltage (Voc) at -10°C and 1250W/m ²	V	101.2	
Short Circuit Current (Isc)	A	1.19	
Short Circuit Current (Isc) at 70°C and 1250W/m ²	A	1.53	
Voltage at Pmax (Vpm)	V	67.0	
Current at Pmax (Ipm)	A	0.90	
Max. System Voltage	V	530	
Fire Rating		Class C	
Dimension	mm	990 ± 2.5 x 960 ± 2.5	
Depth	mm	40 ± 1.0	
Weight	kg	13.7	

(REMARK)

1. During initial 6 weeks of operation, the MODULE has higher electrical output than rated output (See Performance at STC (stabilized)). The Pmax may be higher by 38% and Imp may be higher by 19%.
2. The Electrical characteristics are within ±10% of the indicated values of Isc, Voc, and Pmax under standard test conditions (irradiance of 100mW/cm², AM1.5 spectrum, and a cell temperature of 25°C (77°F)).

3. Specifications subject to change without notice.

4. Under normal conditions, the MODULES may experience conditions that produce more current and/or voltage than reported at Standard Test Conditions. Accordingly, the values of I_{sc} and V_{oc} marked on UL Listed MODULES should be multiplied by a factor of 125% when determining component voltage ratings, conductor capacities, fuse sizes and size of controls connected to the MODULE output. Refer to Article 690-8 of the National Electrical Code for an additional multiply factor of 125% (80% derating), which may be applicable.

5. The type of over current protection is described as Series Fuse 7.0A, Bypass Diode 2.0A.

3.Installation of the MODULES

The assembly is to be mounted over a fire resistant roof covering rated for the application.

5 in/ft (127mm/305mm) required to maintain UL fire class rating.

Artificially concentrated sunlight shall not be directed on the MODULE.

See the Attachment A: Instruction for using G-type (UL grade).

(Remark for C-UL)

Installation shall be in accordance with CSA 22.1, Safety Standard for Electrical Installations, Canadian Electrical Code, Part 1.

All mounting hardware shall be stainless steel

Method (1)

Fix the MODULES to rails with M6 bolts and nuts (4 pairs per module). The platform of the MODULES should have sufficient strength.

[the MODULE mounting diagram]

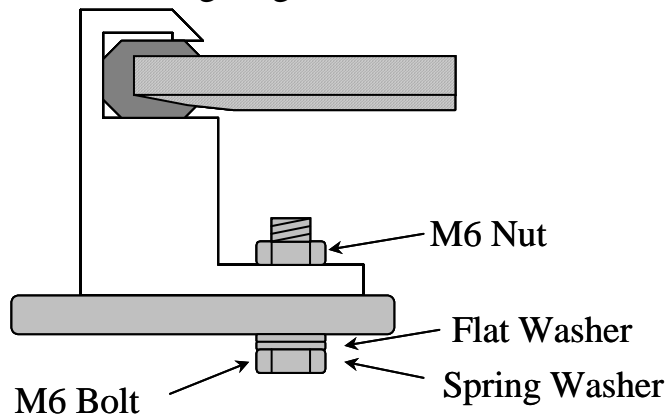

Method (2)

Fix the MODULES to rails with clamps as shown in the picture below.



Recommended mounting system for installation method 2 is “Solar Mount /S-5! PV Clamp Sets” made by UniRac, Inc. Install the mounting system as instructed by a installation manual of the mounting system. (Refer to installation manual provided by UniRac.) Then, fix the MODULES with the cramps (4 pairs or more per module). The cramps should be fixed to the side frames of MODULES. Cramps A - B and C - D in the diagram below must be located symmetrically. The distance between the center of the 2 cramps must be 660 – 950mm.

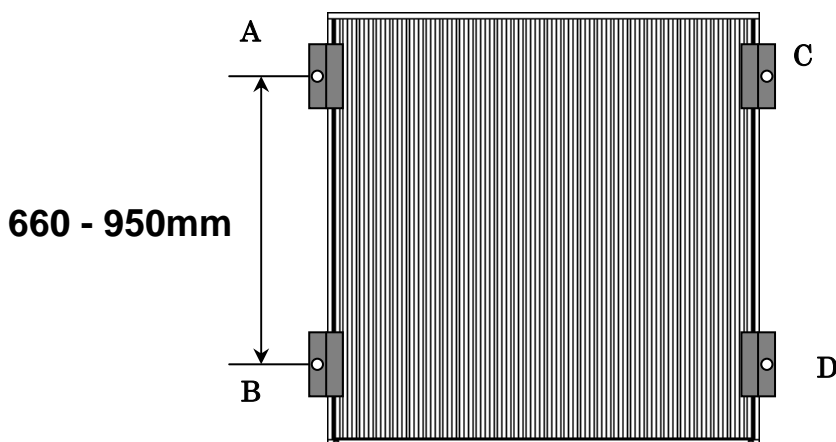

Optimize the tightness of the cramps with greatest care so that the MODULES will not come off and so that the cramps will not break the frames of the MODULES and/or glasses.

Handling Instruction to install a mounting system

- *Do not shock the MODULES (e.g. by stepping on it), as this may break the glass part and cause malfunction, electric shock and injury.
- *Wear a safety belt, protection footwear, and protection gloves when installing the MODULE to prevent falling and electric shock.
- *Beware of electric shock and short-circuit, as the MODULE generates high-tension current when exposed to light.

4.Connecting cables

Use 14 AWG minimum, insulated for 90°C minimum cables.

Stranded Copper only.

When connecting cables, push the plus and minus connectors against each other while twisting them until they are fully engaged.

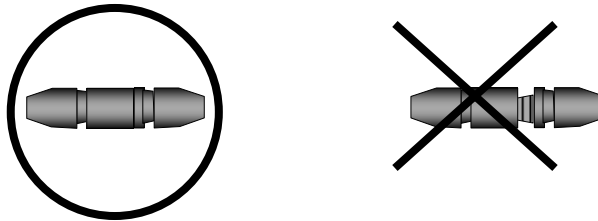

Plus cable connector: PV-KST3II UR (Multi-Contact USA)

Minus cable connector: PV-KBT3II UR (Multi-Contact USA)

Each PV has MC Connector system for photovoltaic, which is supplied from Multi-Contact USA. You should use the same UL recognized connector as written above.

The MODULES employ factory assembled Multi-Contact connectors for interconnection between the MODULES during array assembly in the field. As these connectors can only be assembled in the factory, we recommend the use of commercially available output wiring products, such as (USE-MCUL-50 made by O&S California, Inc.) so that the final array output wiring can be made to a permanent wiring system in accordance with Article 690-31 of the National Electrical Code.

More than five (5) MODULES should not be connected in series. And each string should have a blocking diode or a fuse, which is a 3A of capacity.

See the Attachment A: Instruction for using G-type (UL grade).

5.Ground-connecting

All the MODULES should be ground-connected with the ground holes (marked 'GR') of the MODULES.

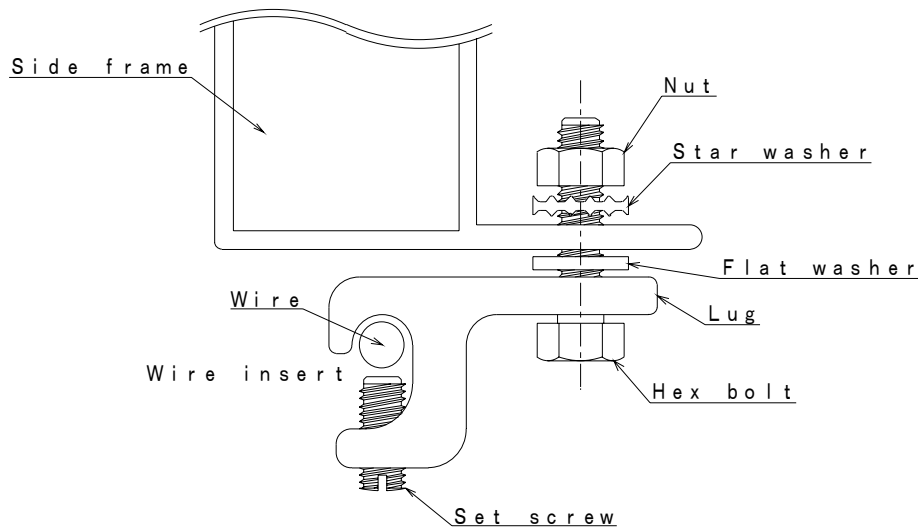

1. Press a stainless steel nut with a star washer and a 10-32 thread into the ground holes (marked 'GR') on the back of frame.
2. Install a ground lug such as the shown ILSCO GBL-4DBT which is UL listed. (User-Provided)
3. A screw shall be used to secure a ground lug as described in the illustration. In this case, the screw threads are not providing the electrical ground contact. However, the screw needs to provide sufficient torque to ensure that the lug is mechanically secure.
4. Connect a minimum #10AWG solid conductor, copper, ground wire to the ground lug.

You will use stainless steel hardware such as bolt, star washer, flat washer and nut to complete the assembly.

Their specifications are as follows:

#10-32 × 1' stainless steel screw, star washer and nut (User-provided)

#10 to 1/4' DIA stainless steel bolt (User-provided)

6.Maintenance

Under the normal use maintenance is not necessary. The dirt on the surface of the MODULES will be washed away by rain.

7.Limitation

See the Attachment A: Instruction for using G-type (UL grade).