



# ME-BMK/ME-BMK-NS

Battery Monitor Kit

Owner's Manual

Thank you from all of us at Sensata Technologies for purchasing the ME-BMK/ME-BMK-NS battery monitor kit. The BMK/BMK-NS is a product under the Magnum-Dimensions brand from Sensata Technologies. We understand there are many purchasing options in the marketplace, and are pleased that you have decided on a Magnum-Dimensions product. This product was proudly assembled and tested in the United States.

We are committed to providing quality products and services. We hope your experience with us is pleasant and professional.

### **Disclaimer of Liability**

The use of this manual and the conditions or methods of installation, operation, use, and maintenance of the battery monitor kit are beyond the control of Sensata Technologies. Therefore, this company does not assume responsibility and expressly disclaims liability for loss, damage, or expense whether direct, indirect, consequential or incidental that may arise out of or be in any way connected with such installation, operation, use, or maintenance.

Due to continuous improvements and product updates, the images shown in this manual may not exactly match the unit purchased.

### **Restrictions on Use**

The ME-BMK/ME-BMK-NS battery monitor may only be used in life support devices and systems with the express written approval of Sensata Technologies. Failure of this product can reasonably be expected to cause failure of that life support device or system, or to affect the safety or effectiveness of that device or system.

### **Copyright Notice**

Copyright 2016 by Sensata Technologies. All rights reserved. Permission to copy, distribute, and/or modify this document is prohibited without written permission from Sensata.

### **Document Information**

Description – ME-BMK/ME-BMK-NS Owner’s Manual

Part Number and Revision – 64-0013 Rev B

Date Published – February 2016

This entire manual is available for download—with many of the installation diagrams available in color—on our website at: [www.Magnum-Dimensions.com/](http://www.Magnum-Dimensions.com/).

### **Contact Information (for Magnum-branded products)**

Sensata Technologies

2211 West Casino Rd.

Everett, WA 98204

Phone: (425) 353-8833 / Fax: (425) 353-8390

Web: [www.Magnum-Dimensions.com/](http://www.Magnum-Dimensions.com/)

### Conventions used in this Manual

#### Safety Symbols

To reduce the risk of electrical shock, fire, or other safety hazard, the following safety symbols have been placed throughout this manual to identify dangerous situations and important safety instructions.



**WARNING:** This symbol indicates failure to take a specified action could result in physical harm to the user.



**CAUTION:** This symbol indicates failure to take a specified action could result in damage to the equipment.



**Info:** This symbol indicates information that emphasizes or supplements important points of the main text.

### IMPORTANT PRODUCT SAFETY INSTRUCTIONS

This manual contains important safety instructions that must be followed during the installation and operation of this product. Read all instructions and safety information contained in this manual before installing or using this product.

- All electrical work must be performed in accordance with local, state, and federal electrical codes.
- This product is designed for indoor/compartment installation. DO NOT expose to rain, snow, moisture, or liquids of any type.
- Use insulated tools to reduce the chance of electrical shock or accidental short circuits.
- Remove all jewelry (such as rings, watches, bracelets, etc.) when installing or performing maintenance on your batteries and the inverter system.
- Always disconnect the batteries or energy source prior to installing or performing maintenance on your batteries and inverter system. Live power may be present at more than one point since an inverter utilizes both batteries and AC. Turning off the inverter may not reduce this risk. As long as AC power is connected, it will pass through the inverter regardless of the power switch on the inverter or the ON/OFF INVERTER pushbutton on the remote/router.
- Wear eye protection such as safety glasses when working with batteries.
- Never work alone. Always have someone near you when working around batteries.
- Never use old or untested batteries. Check each battery's label for age, type, and date code to ensure all batteries are identical.
- Batteries are sensitive to changes in temperature. Always install batteries in a stable environment.
- Install batteries in a well-ventilated area. Batteries can produce explosive gasses. For compartment or enclosure installations, always vent batteries to the outside.

## Table of Contents

<b>1.0</b>	<b>Introduction</b> .....	<b>1</b>
1.1	Product Features .....	1
1.2	Remote Identification and Compatibility .....	1
1.3	Advantages of using a Battery Monitor .....	2
<b>2.0</b>	<b>Installation</b> .....	<b>3</b>
2.1	Required Components and Tools .....	3
2.1.1	Supplied Components .....	3
2.1.2	Other Required Equipment and Materials .....	3
2.2	Installation Procedure .....	5
2.2.1	DC Cable Connections .....	5
2.2.2	ME-BMK Sense Module Connections .....	7
2.2.3	Connecting Multiple Network Devices .....	8
2.2.4	Network Connections using the ME-RTR Router.....	10
<b>3.0</b>	<b>Using the BMK</b> .....	<b>11</b>
3.1	How the BMK Battery Monitor Operates .....	11
3.2	Monitoring the Battery Bank using the ME-BMK .....	12
<b>4.0</b>	<b>Using LED Indicator to Determine BMK Status</b> .....	<b>14</b>
<b>5.0</b>	<b>Specifications</b> .....	<b>15</b>
<b>6.0</b>	<b>Limited Warranty</b> .....	<b>16</b>
6.1	How to Receive Repair Service .....	17

## List of Figures

Figure 2-1,	ME-BMK Basic Installation Diagram.....	4
Figure 2-2,	DC Shunt Connections .....	6
Figure 2-3,	Sense Module Connections .....	6
Figure 2-4,	Multiple Network Devices – Star .....	8
Figure 2-5,	Multiple Network Devices – Daisy Chain .....	9
Figure 2-6,	BMK Directly Connected to Router .....	10
Figure 2-7,	BMK & Router w/ Separate Connections to Inverter...	10
Figure 3-1,	Ending Battery Voltage Verses Time.....	12
Figure 5-1,	Product Dimensions.....	15

## Tables

Table 4-1,	LED Indicator Guide .....	14
Table 5-1,	Product Specifications .....	15

### 1.0 Introduction

The ME-BMK/ME-BMK-NS is a single, battery bank amp-hour meter that monitors your battery and provides important information about the operation of your charging system. This information enables you to determine how much energy is available, and helps you plan electrical usage to ensure the battery is not over-discharged.

The ME-BMK is easy to install and is designed to be networked with a Magnum inverter/charger using a Magnum remote or router to display information about your battery bank.



**Info:** The ME-BMK-NS is identical to the ME-BMK except the NS version does **not** have the DC shunt.



**Info:** The ME-BMK-NS requires a shunt with a 10:1 ratio, so this means the shunt (1000A/100mv) that is included with Magnum's MPSH and MPDH enclosures also works.

### 1.1 Product Features

- Compatible with 12, 24, or 48-volt systems
- Adjustable settings – very easy to set up
- All battery meter, inverter/charger setup and monitoring features in a single convenient display
- Displays reliable and pertinent information, such as: battery state of charge (SOC), battery voltage, and battery current
- Auto-detecting input voltage
- Temperature and battery bank capacity automatically compensated/coordinated between inverter & battery monitor
- Precision 500A/50mv DC shunt (**not** included w/ ME-BMK-NS)
- Automatic efficiency calculation

### 1.2 Remote Identification and Compatibility

The ME-BMK is compatible with all Magnum inverters/chargers that have a Mag Net, Accessory, or Network port. To access the BMK's available settings/features, you need either an ME-RC50 (rev.  $\geq 2.0$ ) or ME-ARC50 remote, or an ME-RTR router.

*If you have a ME-RC50 remote:*



**Info:** You can view the revision level of your ME-RC50 when you first power-up the remote—or by pushing the remote's TECH button and accessing the *02 Revisions* menu.



**Info:** If the ME-BMK is being added to a previously installed Magnum inverter and a ME-RC50 remote with a software Rev.  $< 2.0$ , contact Sensata Technologies/Magnum about ME-RC50 upgrade options.

### 1.3 Advantages of using a Battery Monitor

**Why use a Magnum Battery Monitor?** To ensure your batteries perform satisfactorily and have a long life, they need to be properly maintained and charged. There are several devices that help to determine if the batteries are being fully charged:

- **DC Voltmeter:** An accurate DC voltmeter can be used to measure the Open Circuit Voltage (OCV) across the battery terminals—you can then compare the readings with the OCV values from the battery manufacturer. A DC voltmeter is the least costly, but is also the least accurate and requires the batteries to be “at rest”. This rest requirement means the voltage measurement should only be done when there is no current moving through the battery for a period of time (one hour minimum). Using a DC voltmeter when the batteries are at rest is generally impractical, because the batteries are usually always powering loads or being charged.
- **Hydrometer:** A good hydrometer can be used to measure the concentration of battery electrolyte in each individual cell—you can then compare these readings with the specific gravity values from the battery manufacturer. A hydrometer is very accurate but can be time consuming, and working with sulfuric acid may be unpleasant. A hydrometer won’t work with sealed batteries.
- **Amp-Hour (AH) Meter:** An amp-hour meter is an electronic measuring device that uses a precision shunt to calculate the amp-hours going into (charging) and coming out of (discharging) a battery. This meter tracks the AH usage and compares it against the AH capacity of the battery to determine its charge condition. Calculating *AH In* versus *AH Out* is fairly accurate and is easily displayed, but it doesn’t provide an accurate State Of Charge (SOC) under all discharge and charge conditions.

These devices have both advantages and disadvantages based on accuracy and ease of use. Magnum’s ME-BMK battery monitor combines the advantages of these devices with additional functionality (i.e., monitoring battery temperature and calculating battery efficiencies) to provide an easy and more accurate means to determine the battery’s SOC condition. This helps keep the batteries properly charged.

**What is the difference between Amps and Amp-Hrs?** “Amps” indicate the flow of current going in or out of the battery. “Amp-Hrs” (AH) indicate the amount of current returned to or removed from the battery. Amp-Hrs are a common rating used to calculate the battery’s available capacity. To understand the difference, imagine the battery bank is equivalent to a water tank. Viewing the amps display is like watching a water gauge. You can see the rate of water flow, but you do not know how much water is left in the tank. Counting ‘amp/hrs in/out’ (i.e., SOC) is like viewing the water tank’s level indicator—which tells you how much water is left in the tank.

### 2.0 Installation

Before installing, read this entire section to thoroughly plan the details to ensure your overall system requirements are accomplished.

To assist in planning and designing the installation, review the basic diagram in Figure 2-1. If installing another network device besides the ME-BMK, refer to Sections 2.2.3 and 2.2.4 for options.



**WARNING:** Installations should be performed by qualified personnel—licensed/certified electricians (they must ensure all safety codes and all applicable installation requirements are followed). Review all safety information on page ii.

The ME-BMK sense module is connected to the inverter using the 10' communications cable, and is connected to the DC shunt using the 5' twisted-pair signal wire. Before installing and connecting any wires, determine the communications cable's route to the inverter and the twisted-pair signal wire's route to the shunt.



**Info:** The communications cable may be extended beyond 10', but to ensure voltage accuracy do not extend the 5' blue and orange twisted-pair wire (it can be shorter than 5').



**Info:** For information on the sizes of the battery cable and overcurrent protection device to be used in the installation, refer to your inverter owner's manual.

#### 2.1 Required Components and Tools

##### 2.1.1 Supplied Components

- ME-BMK/ME-BMK-NS Owner's Manual
- Sense module (w/ two #8 x 3/4" Phillips screws)
- 500A/50mv DC shunt (w/ two #8 x 3/4" Phillips screws)\*\*
- 10' Communications cable (w/ 6P-4C RJ14 connectors)
- 5' Twisted-pair 18 AWG (.82 mm<sup>2</sup>) blue & orange signal wires
- 4-Wire phone-splitter\* (if using two network devices)

##### 2.1.2 Other Required Equipment and Materials

- Magnum inverter with a network connection
- ME-RC50 or ME-ARC50 remote, or a ME-RTR router
- Batteries (with appropriately sized cables)
- Short (~18") battery cable (connects shunt to battery neg.)
- In-line fuse holder (with 2-amp DC fuse)
- 4-Wire phone-splitter\* (if more than two network devices)
- Minimum 200AH battery bank capacity

##### 2.1.3 Tools Required to Install the ME-BMK:

- Flat-blade screwdrivers (1/4" and 1/8" blades)
- #2 Phillips screwdriver
- 9/16" open-end wrench or adjustable crescent wrench

\* Phone splitter must be a 4-conductor (or 6) duplex (straight) type.

\*\* The ME-BMK includes the shunt, the ME-BMK-NS does not.



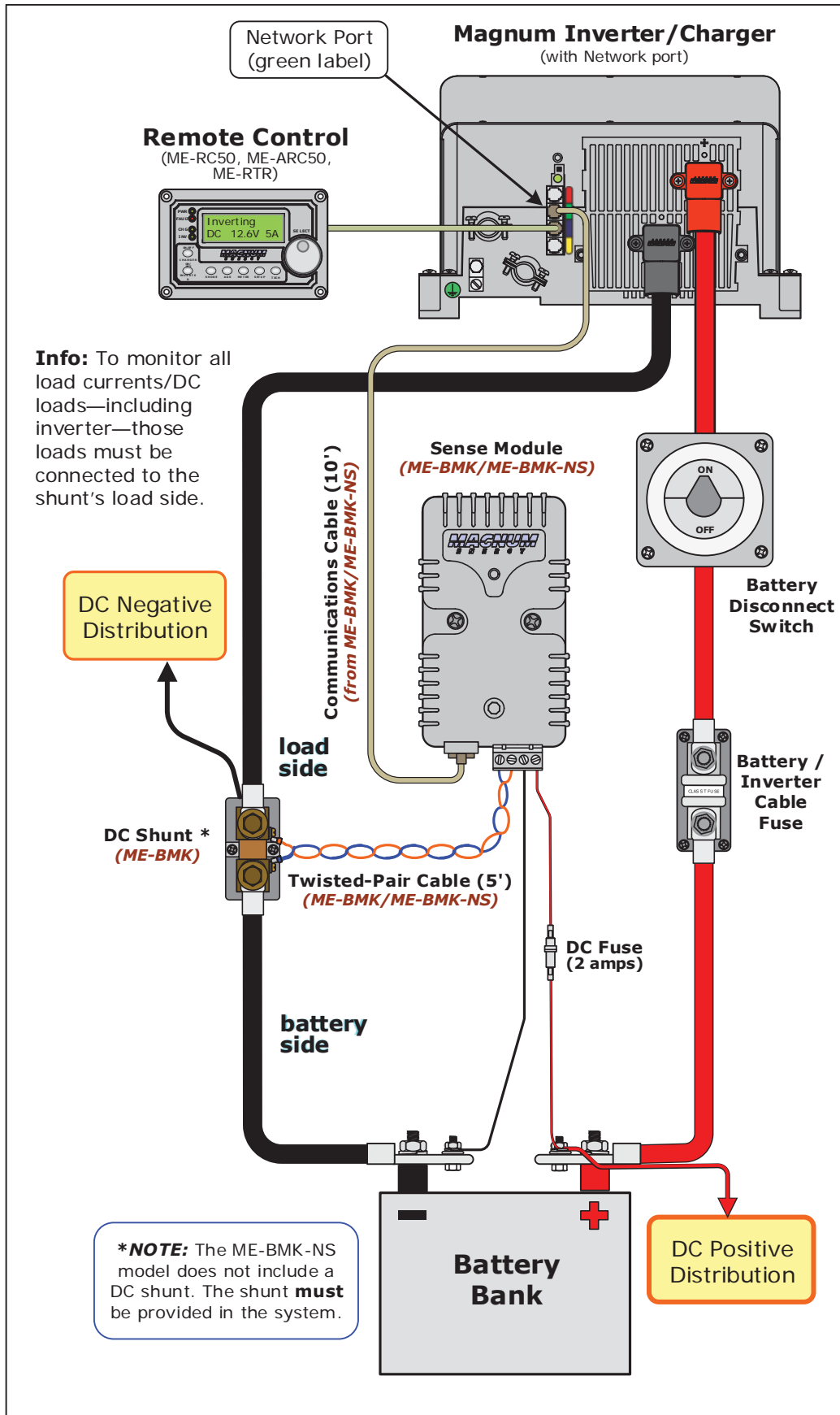

Figure 2-1, ME-BMK Basic Installation Diagram



### 2.2 Installation Procedure

Select a location that is dry and away from extreme temperatures to mount the ME-BMK sense module and DC shunt. Ensure that you can access the shunt's screws and bolts, view the sense module's LED, and have access to the 4-port terminal block and the RJ14 communication port.

**Note:** Refer to Figure 5-1 for sense module and shunt dimensions.



**CAUTION:** Do not mount the ME-BMK in a closed battery compartment, or in an area where water or any other liquid can enter the module and cause shorting or corrosion—this failure is not covered by the warranty.



**CAUTION:** Before installing, ensure all AC power is disconnected from the inverter, and all negative and positive battery cables are disconnected from the battery bank.



**CAUTION:** Ensure all battery negative circuits are always connected before connecting or disconnecting battery positive. This prevents any communication chips/lines from becoming the DC return path to the battery—causing permanent damage to all connected accessories.



**Info:** Shunts require freely circulating air. For continuous operation, do not use at more than 2/3 of its rated current. If not possible, provide adequate forced ventilation to keep the shunt operating at a temperature below 60°C (140°F).



**Info:** Install the shunt as close to the battery bank as practical. This helps prevent voltage drop and mistakenly placing a load between the shunt and the battery.

#### 2.2.1 DC Cable Connections

Once the shunt is mounted, make the following DC connections.



**CAUTION:** The shunt must be installed in the negative DC line. If installed on the positive side, damage may occur.

1. Using an appropriate sized cable, connect the inverter's DC negative terminal to the DC shunt's load side (per Figure 2-1).



**Info:** To monitor all of your system's load currents/ DC loads—including the inverter—those loads must be connected to the shunt's load side.

2. Connect the battery side of the DC shunt to the battery's negative terminal. Secure both DC cables to the shunt using the supplied hardware (per Figure 2-2). Torque from 16 to 20 ft-lbs.
3. Using an appropriate sized cable, connect the inverter's DC positive terminal to the load side of an appropriate DC disconnect/overcurrent protection device (i.e., DC circuit breaker).
4. Open the DC circuit breaker (or remove the fuse) and connect its other side to the positive terminal of the battery bank.

## Installation

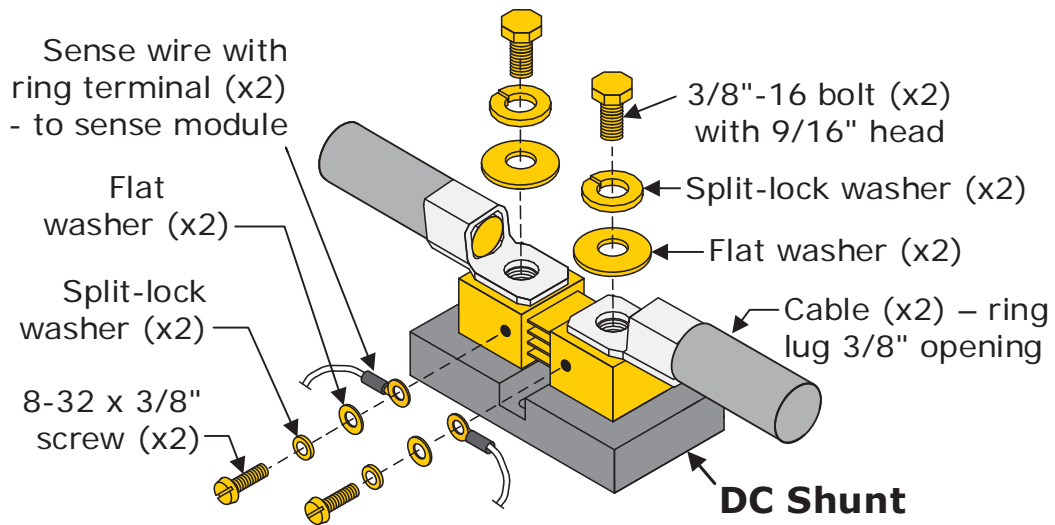

**Figure 2-2, DC Shunt Connections**

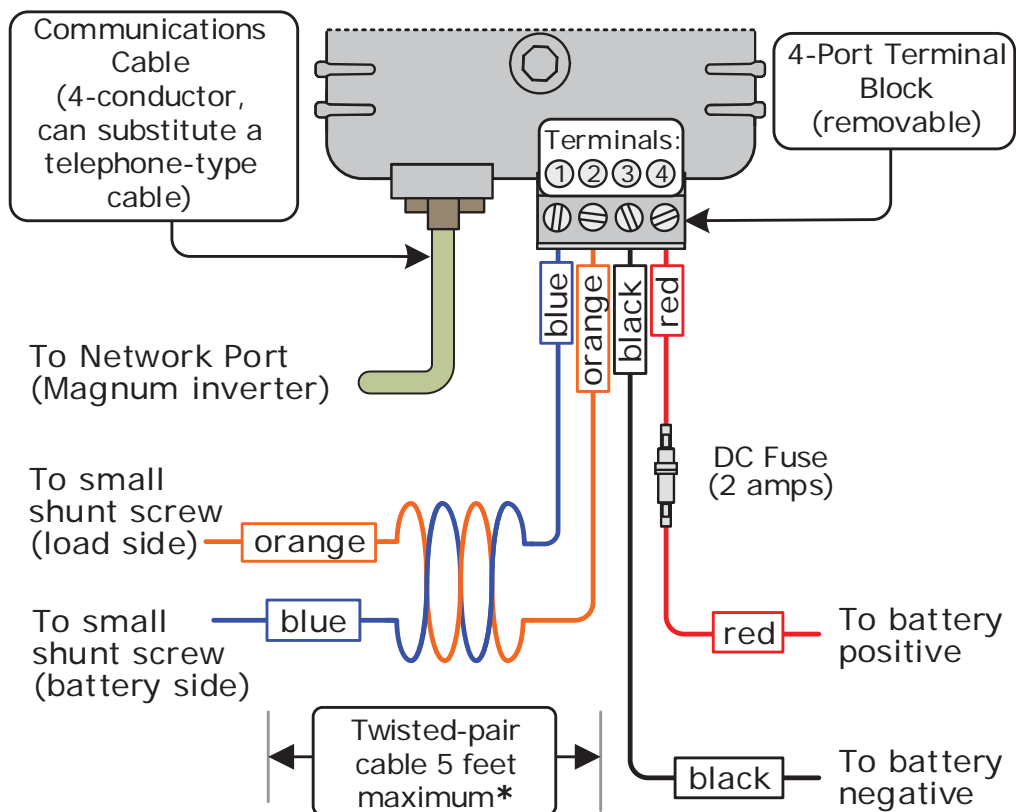

\* Wires can be less than 5 feet, but not longer than 5 feet.

**Figure 2-3, Sense Module Connections**

## Installation

### 2.2.2 ME-BMK Sense Module Connections

Once the ME-BMK is mounted, connect as follows (see Figure 2-3):

1. Connect one end of the communication cable to the inverter's network port, and then connect the other end to the network port on the BMK sense module. See Figure 2-1.
2. Unplug the ME-BMK's 4-port terminal block, and then connect a (black) wire from Terminal #3 on the 4-port terminal block to the negative terminal of the battery.



**CAUTION:** The black power wire must be secured to the negative battery terminal or the BMK could be damaged.



**CAUTION:** A fuse rated at 2 amps must be used to protect all power circuits (except for ground connections) connected to Terminals #3 and #4 on the BMK sense module. Ensure the fuse is correctly rated for the wire size used. Refer to national and local codes for rating and type. Normally, a minimum #16 AWG (1.31 mm<sup>2</sup>) wire is required to use a 2-amp fuse.



**Info:** The black 4-port terminal block accepts conductors from #30 to #12 AWG (0.05 to 3.3 mm<sup>2</sup>).

3. Route and connect a (red) wire with a 2-amp in-line fuse from Terminal #4 on the 4-port terminal block to the positive terminal of the battery.



**CAUTION:** The black and red power wires from the BMK to the battery must not be connected to the input sense terminals (i.e., Terminals #1 & #2).

4. Using the supplied 5' twisted-pair wire: a) Connect the ring terminal end of the blue wire to the small screw on the **battery side** of the shunt; then, b) Connect the ring terminal end of orange wire to the small screw on the **load side** of the shunt. Use Figures 2-1 & 2-2 as guides before connecting.



**Info:** Torque the supplied 8-32 x 3/8" screws to 18 in-lbs (securing the blue/orange twisted pair wires to shunt).



**Info:** Ensure the blue/orange wires stay twisted together up to the shunt to maintain accuracy. These wires can be shorter than 5', but should not be longer than 5'—both wires must be exactly the same length and size.

5. After all connections are made/checked, plug the 4-port terminal block into the ME-BMK (close the DC circuit breaker or DC disconnect, if applicable) to supply power to the inverter and sense module.
6. Once DC power is applied, the sense module's LED should light as the unit goes through a power-up self-test. After the initial self-test completes, the LED should be green. If so, your battery monitor system is now ready for setup; if not, see Section 4.0.

### 2.2.3 Connecting Multiple Network Devices

If you are using more than one Magnum networked device, use the supplied 4-wire phone-splitter to connect the devices to the inverter. There are two interconnection options: Star or Daisy Chain.



**Info:** Before deciding on which configuration to use, review the differences in installation and ease of troubleshooting.

- Star Configuration** – In this arrangement, all network devices connect to the inverter’s network port\* via a phone-splitter, using individual cable runs (Figure 2-4). As each device is independently connected to the inverter’s network port, problems in a cable or in a device can be easily isolated—if there is a cable failure to one device it does not bring down all the other devices.

\* **Note** – The MM/MMS Series use the Remote (blue) port as the network port. Do not plug a network device in to the Accessory (yellow) port.

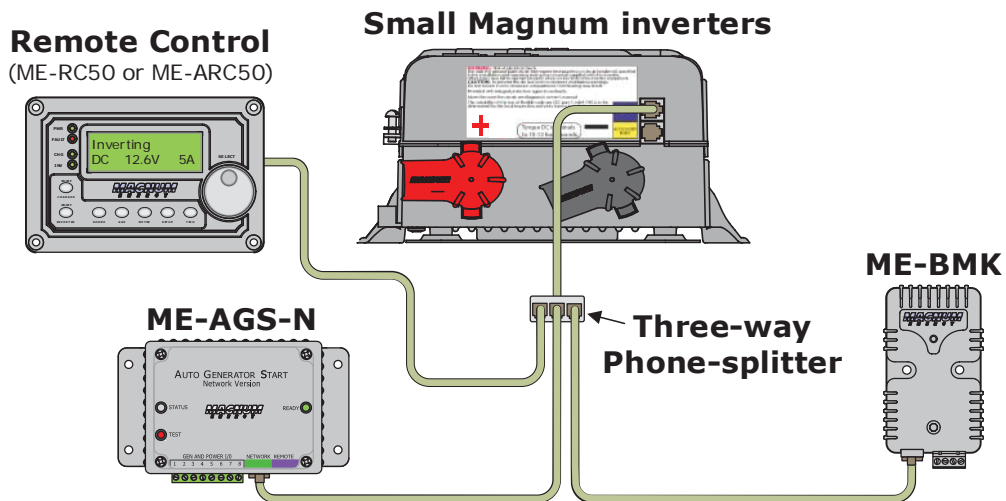
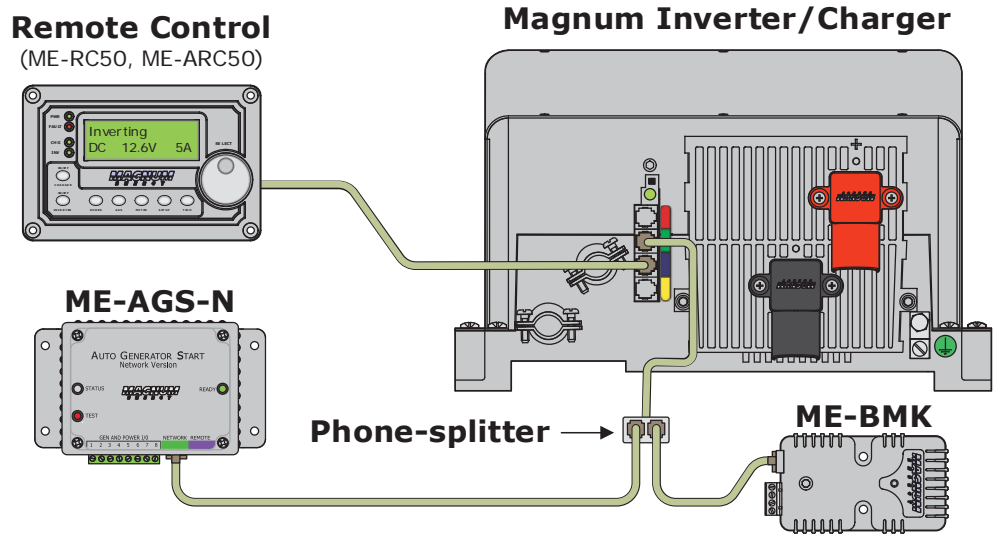

Figure 2-4, Multiple Network Devices – Star Configuration

## Installation

- **Daisy Chain Configuration** – In this arrangement, the network devices are linked in a series (see Figure 2-5). If using this configuration, the first device connected to the inverter's network port\* must be the ME-AGS-N—followed by the ME-BMK.

\* **Note** – The MM/MMS Series use the Remote (blue) port as the network port. Do not plug a network device in to the Accessory (yellow) port.

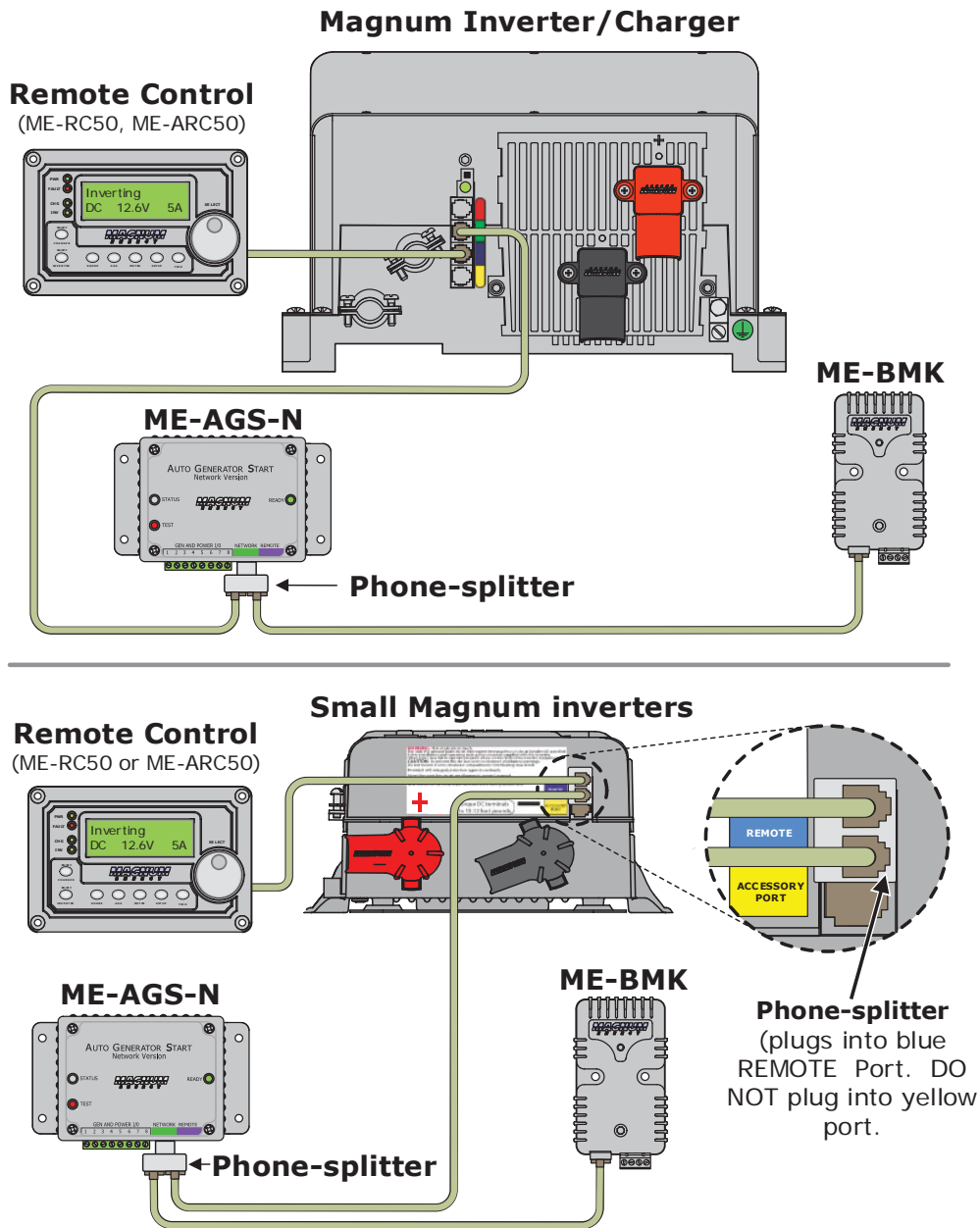

Figure 2-5, Multiple Network Devices – Daisy Chain Configuration

### 2.2.4 Network Connections using the ME-RTR Router

If you are using a Magnum router, it is possible to connect the BMK either directly to the router (see Figure 2-6) or directly to the inverter (see Figure 2-7).



**Info:** When using a router, each network device needs to be plugged in to an individual port—to prevent data confusion (do not use the 4-way splitter).

- **Direct to Router Configuration** – In this arrangement, the BMK device is directly connected to the router (via a Comm port)—which in turn is connected to the inverter.

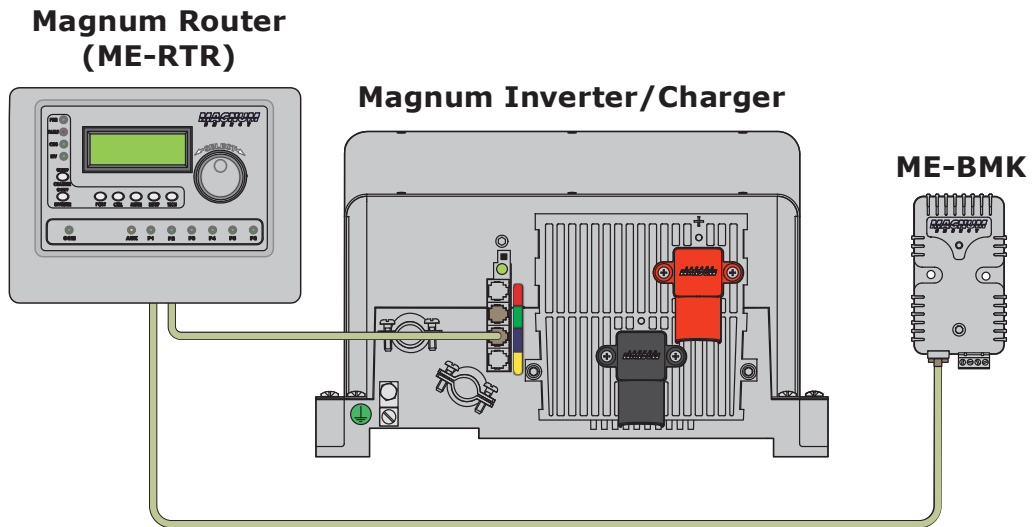

*Figure 2-6, BMK Directly Connected to Router*

- **Direct to Inverter** – In this arrangement, the router and the BMK devices are each directly connected to the inverter via separate ports.

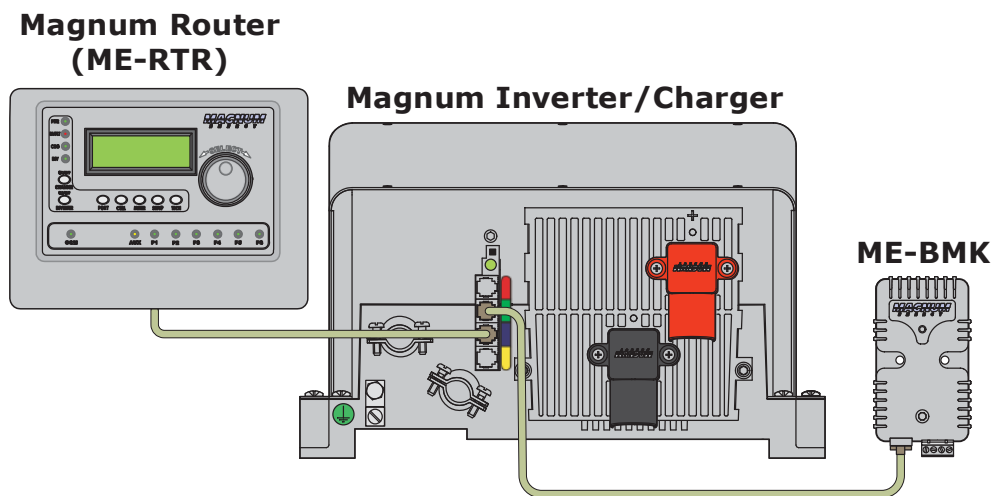

*Figure 2-7, BMK and Router w/ Separate Connections to Inverter*

### 3.0 Using the BMK

This section explains how the ME-BMK battery monitor works.

**IMPORTANT:** Please refer to your remote/router owner's manual for detailed instructions on adjusting the charge efficiency and amp-hour size, and monitoring the various BMK meters.

#### 3.1 How the BMK Battery Monitor Operates

The ME-BMK uses a precision resistor—known as a shunt—to measure current flow into and out of the battery. The shunt provides a small voltage to the BMK sense module that is proportional to the current flow. When the battery current starts flowing, the sense module measures the amount of current removed from and returned to the battery. The amount of current (or AH) removed or returned is displayed on your remote/router as an "AH In/Out" value. This AH in/out value is compensated by the *Charge Efficiency* setting, which accounts for energy losses while charging and is one of the factors used to determine the battery's State Of Charge (SOC).

The battery's state of charge—which is the best indicator of the condition of the batteries—is indicated on your remote/router's SOC display. This display shows that the batteries are fully charged (i.e., SOC = 100%) once the following three conditions have been met:

1. The charging voltage stabilizes over time (see Figure 3-1).
2. The charging current decreases to a low percentage of the AH capacity—normally less than 2%.
3. The AH removed from the battery are within 1% of fully being returned.

When the BMK sense module is first connected, the batteries need to be fully charged (i.e., SOC = 100%) at least once to establish a SOC reference point. After the batteries have reached 100% SOC and have discharged  $\geq 0.5\%$  of the battery capacity setting, the charge efficiency value is recalculated and the AH in/out read-out resets to zero.



**Info:** To help maintain the accuracy of the SOC display and to keep the batteries in good condition, occasionally they must be charged to 100% (approximately once per week).



**Info:** Charging from a generator adds some concern about the cost of fuel. A balance should be considered between the use of fuel and the need to charge your batteries to 100% SOC—to maintain the full service life of a battery. Batteries discharged to 50% SOC and then normally recharged to 85-90% SOC may be an efficient compromise between fuel cost and battery life. Trying to restore the last 10-15% of a full battery charge may require a long time—typically several hours.



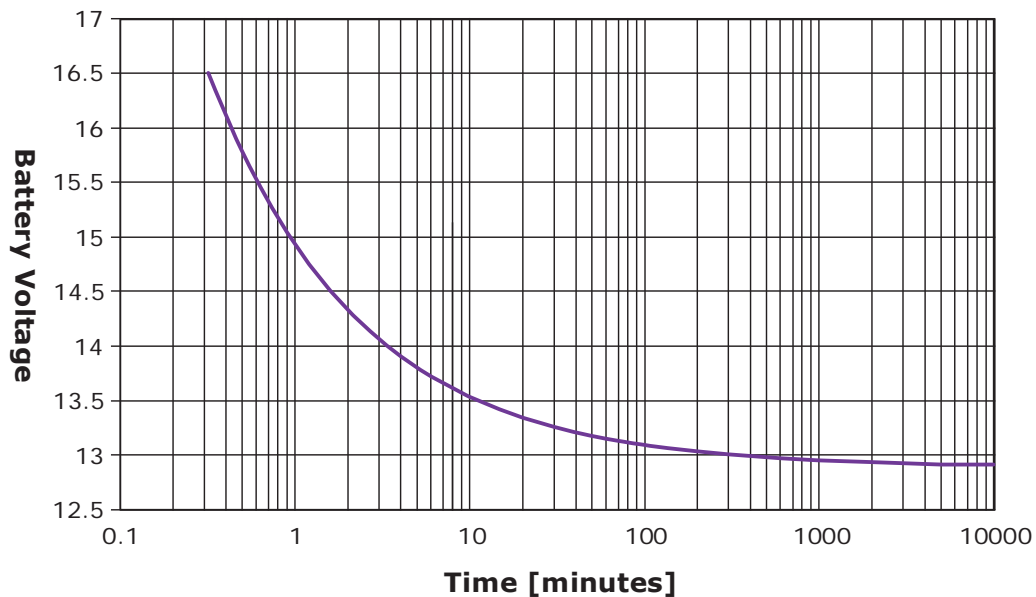

*Figure 3-1, Ending Battery Voltage Verses Time*

### 3.2 Monitoring the Battery Bank using the ME-BMK

You can monitor your battery bank using the BMK menu items from a Magnum remote/router. The remote/router has two adjustable BMK menu options: charge efficiency and amp-hour (AH) size; and also provides numerous read-only BMK meters to monitor your batteries (e.g., DC volts, DC amps, AH I/O, rAH Out, tAH Out, etc.).\*

**What is Charge Efficiency?** When a certain amount of energy is removed or discharged from the battery, this removed energy will need to be returned to keep the batteries at a 100% state of charge. As batteries are being charged, they lose energy—either in the form of heat, or while gassing. This loss of energy while charging means the battery will not be fully charged if you only return the current that was removed. To compensate for the battery's inefficiencies while charging, a *Charge Efficiency* setting is provided. The *Charge Efficiency* setting compensates the AH in/out reading by ensuring the AH returned to the battery are greater than the AH removed.



**CAUTION:** The factory default *Charge Efficiency* setting is *Auto*, which allows charging efficiency to be automatically calculated. Typically, this setting determines the best charge efficiency. If you do not know your battery's charging efficiency, leave it at the factory default setting. If the setting is manually set but incorrect, the state-of-charge information will become more inaccurate with every charge.

\* – The ME-ARC remote and ME-RTR router provide additional BMK meter menus and BMK features not available with the ME-RC. Refer to your remote/router owner's manual for more information.

**Should I adjust the Charge Efficiency setting?** The *Charge Efficiency* setting allows the battery monitor to calculate the battery's charge efficiency. The charge efficiency can be calculated automatically using the *Auto* setting, or can be manually programmed by the user (using a Magnum remote/router).

The ME-BMK is shipped with the charge efficiency set to *Auto*. This allows the battery monitor to automatically calculate variables that affect the charging efficiency, such as: battery type, battery age, and how the batteries are maintained—which is not always constant. With the *Auto* setting, the efficiency is recalculated each time the batteries reach a 100% state of charge (SOC).

This setting can also be manually adjusted from 50% to 99% if the battery's charge efficiency is known. With a setting other than *Auto*, the BMK uses the manual setting to calculate the AH in/out value.

**Example:** Charge efficiency is set to 90% and 100 AH are removed from the battery—the SOC display reads 100% only after 111 AH ( $100 \text{ AH} \div 90\%$ ) have been returned to the battery. However, if the charge efficiency is manually set and inaccurate, the SOC information will be more inaccurate with every charge.

If you set a manual charge efficiency, you must continually monitor the AH in/out value (along with the SOC display) using your Magnum remote/router to ensure charge efficiency is correct.

**What is the Amp-Hour Size setting?** This setting is used by the BMK battery monitor to calculate the battery's state of charge. The AH size represents the amount of energy the battery can deliver.



**CAUTION:** It is important that the amp-hour size setting is correct or else the calculations used to determine the battery's SOC display will be inaccurate.

**Where do I set Amp-Hour Size?** Select the setting based on the 20-hr AH capacity of your battery bank. Refer to the battery manufacturer for the 20-hr AH capacity of your batteries.

**How do I determine my Battery Amp-Hour capacity?** The batteries should be a deep-cycle type and rated either by AH or reserve capacity in minutes.

- Amp-hour (AH) capacity is a measurement of how many amps a battery can deliver for a specified length of time (usually 20 hrs) until the voltage achieves 1.75 VDC/cell at 80°F (27°C).
- Reserve Capacity (RC) is a measure of how many minutes a battery can deliver a certain amount of current (usually 25A) and maintain a voltage above 1.75 VDC/cell at 80°F. If using the Reserve Capacity (25A), the 20-hr AH capacity can be estimated by multiplying 'minutes reserve capacity' by 50%.

Battery capacity ratings tend to be optimistic and decrease at lower temps, so this setting should be less than the published 20-hour AH capacity of the battery bank. After obtaining the 20-hour AH capacity, adjust this setting slightly lower (i.e., smaller AH value).

#### 4.0 Using LED Indicator to Determine BMK Status

The bi-color LED indicator on the front of the sense module is used to determine the battery monitor's status. When the sense module is first powered up, the LED blinks red and green while going through a self-test. Once the self-test is complete, use Table 4-1 below and the LED indicator on your BMK to determine its operating status.

See the BMK Troubleshooting section of your Magnum remote/router owner's manual to troubleshoot BMK faults on the remote/router.

**Table 4-1, LED Indicator Guide**

LED Status	Meaning
OFF	1) No power going to sense module. Check for correct DC voltage (7 to 70 VDC) and polarity from pin 3 (-) to pin 4 (+) on the terminal block; or, 2) Ensure the terminal block is correctly seated into the sense module.
Red ON, Green ON, Red On, Green ON	Power-up sequence (1 sec. interval between each color). The sense module is performing a self-test—this occurs when first connected to power.
Green ON	Normal operation: the sense module is correctly communicating with the network devices.
Green BLINKING	Not able to communicate with remote display. A) If remote/router display is off, troubleshoot with remote/router owner's manual. Ensure the inverter is on and the correct communications cable is connected to the inverter's remote port. B) If the RC50 remote display is on, ensure the remote display is Revision 2.0 or higher. RC50 remote displays with revisions prior to 2.0 are not compatible with the ME-BMK.
Red ON	The power-up sequence failed. Unplug the sense module's 4-port terminal block and check for correct DC voltage on pins 3 & 4 (must be between 7 to 70 volts DC depending on the nominal voltage of the inverter).
Red BLINKING	No communication, or an unrecognizable communication on the network. Check the communications cable, ensure it is connected correctly. If the communications cable is missing, a standard 4-conductor telephone cable may be temporarily substituted. <b>Important:</b> Ensure the RJ14 connector is pushed into the correct port; you should feel/hear a "click" when the connection is made.

## 5.0 Specifications

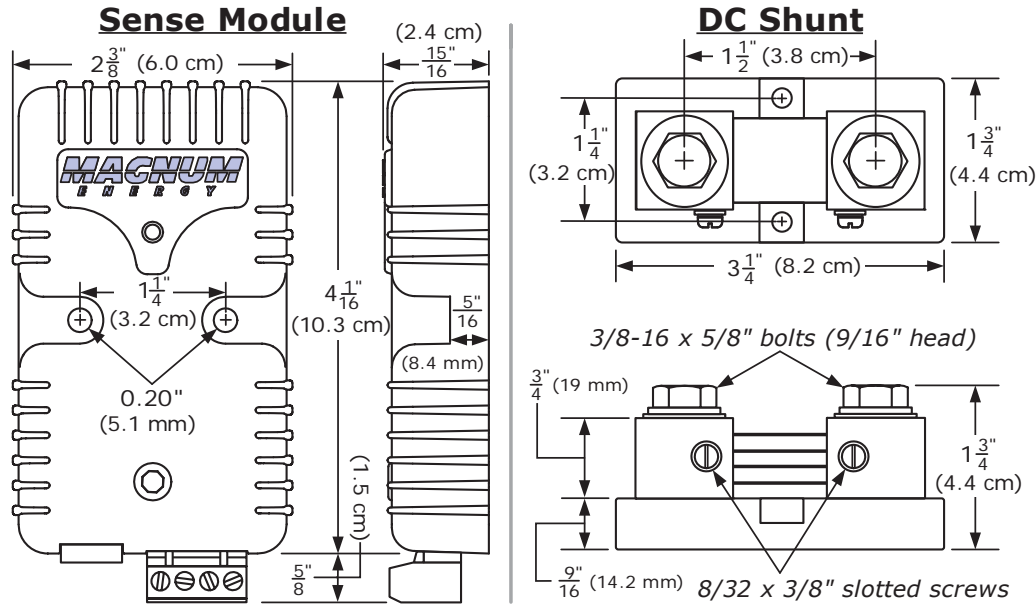

Figure 5-1, Product Dimensions

Table 5-1, Product Specifications

Sense Module/Meter Specifications	
DC Volts	7.0 to 70 volts ( $\pm 0.5\%$ ) auto voltage detection
DC Amps	$\pm 0.1$ to 999 ( $\pm 1.0\%$ )
Battery SOC %	0 to 100% (1% increments)
Power Draw	< 0.6 watts
AH I/O (In/Out)	$\pm 32,768$ AHs (1 AH increments)
rAH Out	0 to 65,535 AHs, resettable (0.1 AH increments)
tAH Out	0 to 65,535,000 AHs (0.1k or 100 AH increments)
Min/Max Battery AH	200-2500 AH
Min/Max DC Meter	7 to 70 VDC, resettable
Shipping Weight	$\sim 2$ lbs. (w/ manual, sense module, DC shunt, twisted-pair wire and communication cable)
Sense Wire	Twisted-pair, 5' length, 18 AWG wire
Communications Cable	4-conductor, 10' twisted-pair, telephone standard
DC Shunt Specifications	
Resistance	0.1 milliohm (500 amps at 50-millivolts)
Continuous Current	410 amperes maximum
Overload Current	Can take overloads to 500 amps for <5 minutes if normally operated at <300 amps.

## 6.0 Limited Warranty

Sensata Technologies warrants the ME-BMK to be free from defects in material and workmanship that result in product failure during normal usage, according to the following terms and conditions:

1. The limited warranty for this product extends for 12 months beginning from the product's original date of purchase.
2. The limited warranty extends to the original purchaser of the product and is not assignable or transferable to any subsequent purchaser.
3. During the limited warranty period, Sensata will repair or replace (with factory new or rebuilt replacement items) at Sensata's option any defective parts, or any parts that will not properly operate for their intended use—if such repair or replacement is needed because of product malfunction or failure during normal usage. The limited warranty does not cover defects in appearance (cosmetic or decorative), or any structural or non-operative parts. Sensata's limit of liability under the limited warranty shall be the actual cash value of the product at the time the original purchaser returns the product for repair, determined by the price paid by the original purchaser. Sensata shall not be liable for any other losses or damages.
4. Upon request from Sensata, the original purchaser must prove the product's original date of purchase by a dated bill of sale, or itemized receipt.
5. The original purchaser shall return the product prepaid to Sensata in Everett, WA. After the completion of service under this limited warranty, the product will be returned prepaid to the original purchaser via a non-expedited surface freight within the contiguous United States and Canada; this excludes Alaska and Hawaii.
6. If Sensata repairs or replaces a product, its warranty continues for the remaining portion of the original warranty period or 90 days from the date of the return shipment to the original purchaser, whichever is greater. All replaced products/parts removed from repaired products become the property of Sensata.
7. This limited warranty is voided if:
  - the product has been modified without authorization
  - the serial number has been altered or removed
  - the product has been damaged through abuse, neglect, accident, high voltage or corrosion
  - the product was not installed and operated according to the owner's manual

**A RETURN MATERIAL AUTHORIZATION (RMA) NUMBER IS  
REQUIRED BEFORE RETURNING ANY PRODUCT**

### 6.1 How to Receive Repair Service

If your product requires warranty service or repair, contact:

- Sensata Technologies (Magnum Energy-branded products) at:  
Telephone: 425-353-8833  
Fax: 425-353-8390  
Email: [MagnumWarranty@Sensata.com](mailto:MagnumWarranty@Sensata.com)

If returning your product directly to Sensata for repair, you must:

1. Return the unit in the original, or equivalent, shipping container.
2. Receive a Return Materials Authorization (RMA) number from the factory prior to the return of the product to Sensata.
3. Place the RMA numbers clearly on the shipping container or on the packing slip.

When sending your product for service, please ensure it is properly packaged. **Damage due to inadequate packaging is not covered under warranty.** We recommend sending the product by traceable or insured service.



Magnum-Dimensions Products

Manufactured by:

Sensata Technologies

2211 West Casino Rd.

Everett, WA 98204

Phone: (425) 353-8833

Fax: (425) 353-8390

Web: [www.Magnum-Dimensions.com/](http://www.Magnum-Dimensions.com/)