



DPW | SOLAR



PREFORMED LINE PRODUCTS



LARGE GROUND MOUNT

Assembly Instructions

**step-by-step
assembly and installation**

The Large Ground Mount

A few words about the product

The Large Ground Mount (LGM) is designed to mount on 2 or 2-1/2 inch SCH40/80 galvanized steel pipe (installer supplied). The goal of the LGM design is to increase the quantity of modules stacked in a vertical column while limiting the size of the SCH40/80 galvanized pipe.

Pipe size and foundation requirements are based on several factors including the array surface area, maximum design wind speed, exposure category, soil type, steepest expected tilt angle, and above-ground clearance.

For foundation and pipe size recommendations on a specific installation, contact us at:

Phone: 800-260-3792

Email: info@power-fab.com.

WARNING

STAINLESS STEEL HARDWARE CAN GALL WHEN TIGHTENED TOO QUICKLY. INSTALLER SHOULD USE A SILVER GRADE ANTI-SIEZE COMPOUND PRIOR TO ASSEMBLING ANY STAINLESS STEEL HARDWARE. DO NOT USE AN IMPACT DRIVER. ALL OTHER DRIVER TYPES SHOULD BE SET TO LOW SPEED SETTINGS.

Assembly Instructions

WARNING:
Follow the procedures and precautions in these instructions carefully.

These instructions include information on assembling the product and are intended to be used by individuals with sufficient technical skills for the task. Knowledge and use of hand tools, measuring devices and torque values is also required.

Included in these instructions are various Notes, Cautions, and Warnings that are intended to draw your attention and assist in the assembly process and/or to draw attention to the fact that certain assembly steps may be dangerous and could cause serious physical injury and/or damage to components. Follow the procedures and precautions in these instructions carefully.

Required Tools

- 1/2 inch wrench or socket for 5/16 inch hardware
- 9/16 inch wrench or socket for 3/8 inch hardware
- Torque wrench
- Ratchet wrench
- Ratchet extension bar
- 3 to 6 foot level
- Framing square
- Tape Measure

1	South Top Sleeve, (5/16" x 3/4") carriage bolt, flange nut	1 per southern Vertical Pipe
2	3/8" U-Bolt, flange nuts	2 per Top Sleeve, 1 per Rail Bracket
3	N-S Cross-Brace, Power Rail P8	1 per set of N-S Vertical Pipes
4	North Top Sleeve, (5/16" x 3/4") carriage bolt, flange nut	1 per northern Vertical Pipe
5	Collar, (5/16" x 3/4") carriage bolt, flange nut	2 per northern Vertical Pipe
6	Universal End Clamp	4 per Rail Set
7	Diagonal Cross Brace, Power Rail P8	1 between every-other northern Vertical Pipe Set
8	Module Rail, Power Rail P8	2 per Rail Set
9	Rail Bracket **	4 per Rail Set
10	RAD Mid-Clamp, (5/16" x *) bolt, flange nut	2 per 3/8" gap between modules
11	RAD End-Clamp, (5/16" x *) bolt, flange nut	4 per Rail Set
12	Mid Clamp, (5/16" x *) carriage bolt, flange nut	2 per 3/8" gap between modules
12	End-Clamp, (5/16" x *) carriage bolt, flange nut	4 per Rail Set
* 2", 2-1/4", 2-1/2" or 2-3/4" bolt. Length is dependent on depth of PV Module frame		
** Rail Bracket may differ in length and hole quantity (dependent on site-specific environmental conditions)		
Notes: 1. Option to install Mid Clamp with carriage bolt or RAD Mid Clamp.		
2. Option to install Universal End Clamp, End Clamp with carriage bolt or RAD End Clamp.		

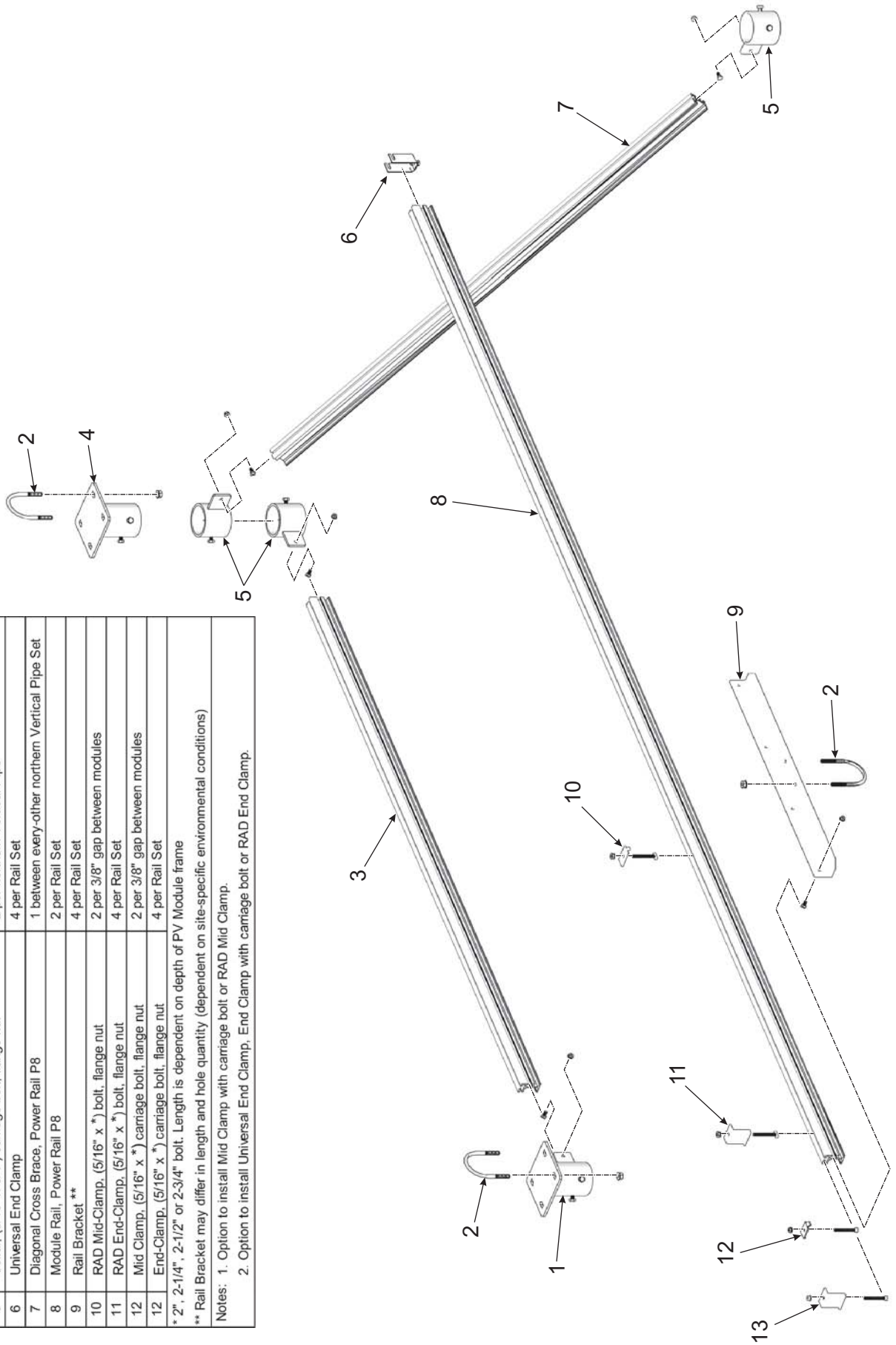

Large Ground Mount Parts Identification

Assembly of the Large Ground Mount

CAUTION:

Before assembly, be certain that the vertical pipe installation has met the project requirements and the concrete footings have fully cured.

NOTE:

For foundation and pipe recommendations, fill out the LGM RFQ form and email to: info@power-fab.com

Step 1: Install Collars on Northern Vertical Pipes

Before installing the Collars, verify that the vertical pipe runs are plumb and that their tops are level, i.e., the tops of the northern run of pipe are level and the tops of the southern run of pipe are level. Also confirm that no shifting of the pipes took place during the concrete curing.

Collars slip onto the northern run of vertical pipes. They have two 3/8" Set Bolts to secure their position on the vertical pipe. Collars are attachment points for the P8 Power Rail bracing that runs between the vertical pipes. This bracing runs in two directions: N-S between the north/south vertical pipes or E-W diagonally between the north vertical pipes. Placement of diagonal bracing is design specific. Refer to design drawings for the quantity, locations, and orientation of the Collars. (See Figures 1-1 and 1-2)

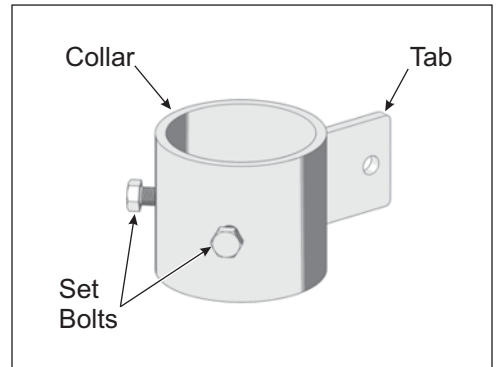

Figure 1-1: Typical Collar

The vertical positioning of the Collars is dependent on two factors: (1) the height of the Tab of the southern Top Sleeves and (2) the height required to properly fit a length of diagonal bracing between two northern vertical pipes.

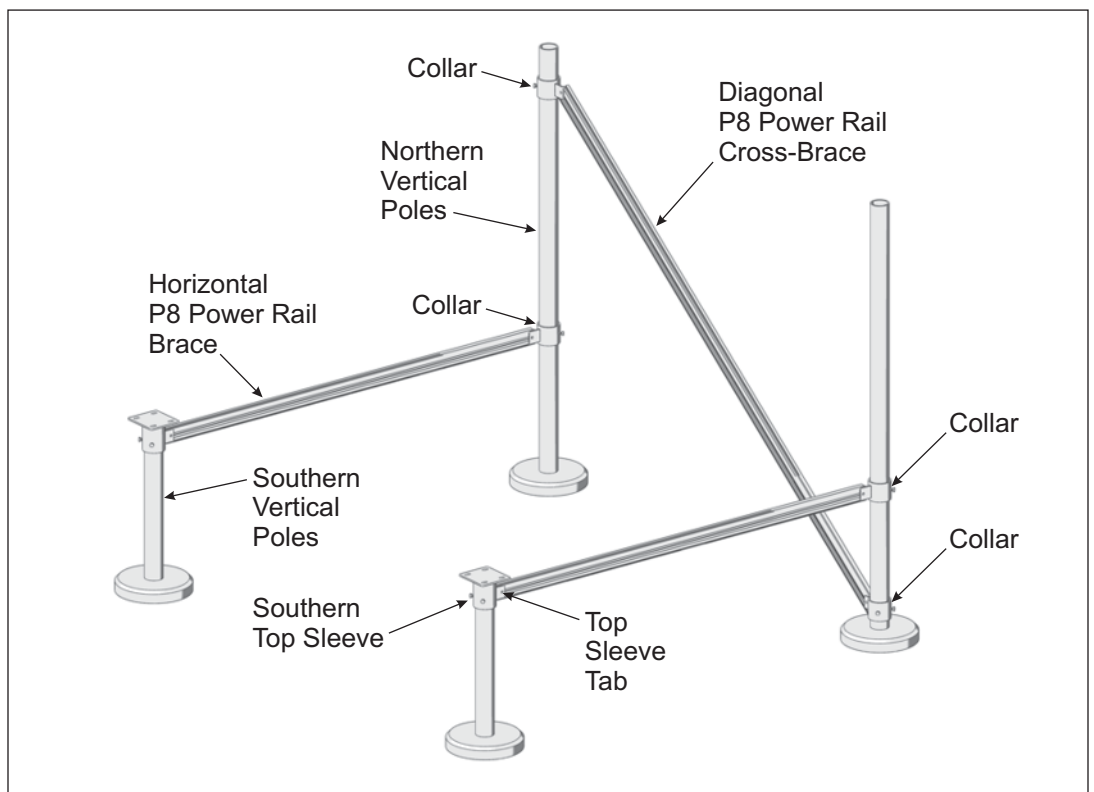

Figure 1-2: Typical Collar Placement and Usage

NOTE:

The Collars must be pre-loaded onto the northern Vertical Pipes before the Top Sleeves are installed.

Pre-Loading Collars on northern Vertical Pipes

Pre-loading the Collars onto the northern Vertical Pipes must be done prior to installing the northern Top Sleeves.

Refer to the design specific drawings and account for both the quantity of collars and their locations. Vertical positioning and securing of the collars will take place later, during the installation of the Rail Bracing.

- A. Slip the Collar over the top of the vertical pipe, slide it downward until it rests on the concrete footing. (See Figure 1-3)
- B. Continue in this manner, pre-loading all remaining collars.

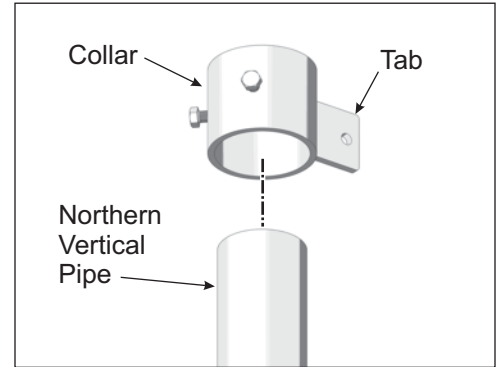

Figure 1-3: Typical Collar

Step 2: Installing Top Sleeves

There are two types of Top Sleeves: one for the northern vertical pipes and one for the southern vertical pipes. The only difference is the southern Top Sleeves have a tab mounted on their sides. (See Figures 2-1 and 2-2)

Installing Northern Top Sleeves

The northern Top Sleeves slip on top of the northern vertical pipes. They have two 3/8" Set Bolts which are used to secure them to the vertical pipe. (See Figure 1-2)

- A. Slip the north Top Sleeve on top of the vertical pipe, sliding it downward until it rests/bottoms out on the vertical pipe.
- B. Rotate the north Top Sleeve so the Set Bolts are pointing south and the slots in the plate are running north/south.
- C. For now, finger tighten the Set Bolts, as they will be tightened and torqued after the horizontal pipes have been installed.
- D. Continue in this manner and install remaining northern Top Sleeves.

CAUTION:

Use care while working around the structure during assembly. There could be components that create hazards or obstruct free movement causing serious bodily injury. Many are at head/eye level. Move slowly and with care around the work area.

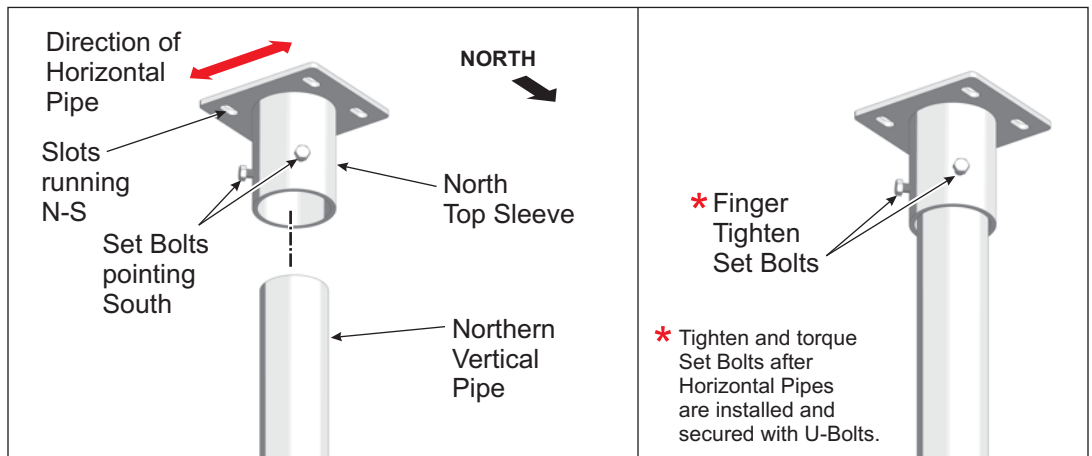

Figure 2-1: Installing Northern Top Sleeves

Installing Southern Top Sleeves

The southern Top Sleeves slip on top of the southern run of vertical pipes. They have two 3/8" Set Bolts which are used to secure them to the vertical pipe. (See Figure 2-2)

- A. Slip the south Top Sleeve on top of the vertical pipe and slide it down until it rests/bottoms out on the vertical pipe.
- B. Rotate the south Top Sleeve so the Set Bolts are pointing south and the slots in the plate are running north/south. This also positions the Tab of the sleeve to be pointing to the north.
- C. For now, finger tighten the Set Bolts, as they will be tightened and torqued after the horizontal pipes have been installed.
- D. Continue in this manner and install remaining southern Top Sleeves.

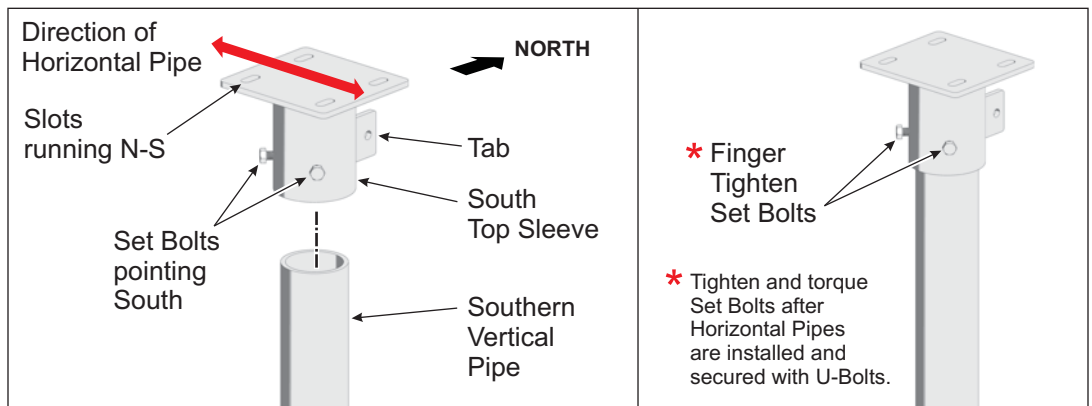

Figure 2-2: Installing Southern Top Sleeves

Step 3: Installing Bracing

Bracing is attached to the Tab of the Southern Top Sleeves at one end and the Tab of the pre-loaded Collars on the northern Vertical Pipes at the other end. The Cross-Bracing is secured using 5/16 inch Turn bolts or carriage bolts and flange nuts.

Attaching N-S Cross-Brace to Southern Top Sleeve

- A. Slide a 5/16" x 3/4" carriage bolt into the Cross-Brace channel.
- B. Insert the carriage bolt into the Tab mounting hole and secure with 5/16" flange nut. For now, finger tighten only. (See Figure 3-1)

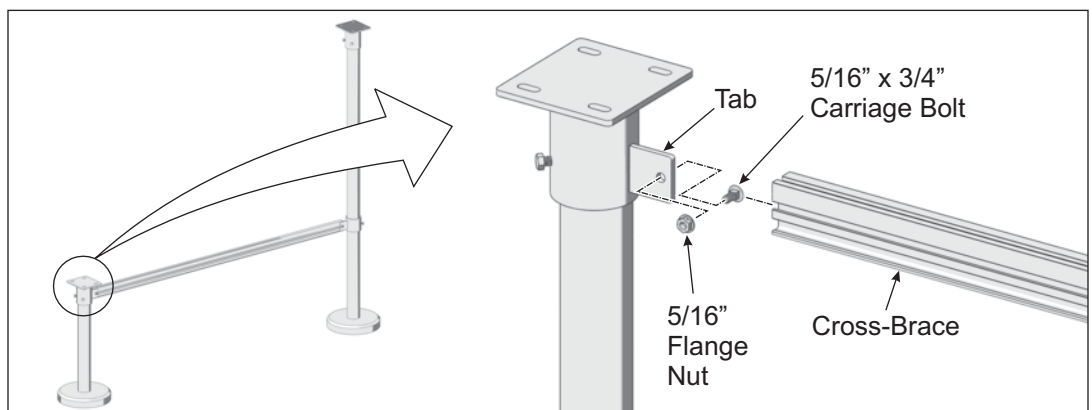

Figure 3-1: Attaching N-S Cross-Bracing to South Top Sleeve

Attaching Cross-Brace to Northern Collar

- A. Slide a 5/16" x 3/4" carriage bolt into the Cross-Brace channel.
- B. Insert the carriage bolt into the Tab mounting hole and secure with 5/16" flange nut. For now, finger tighten only. (See Figure 3-2)

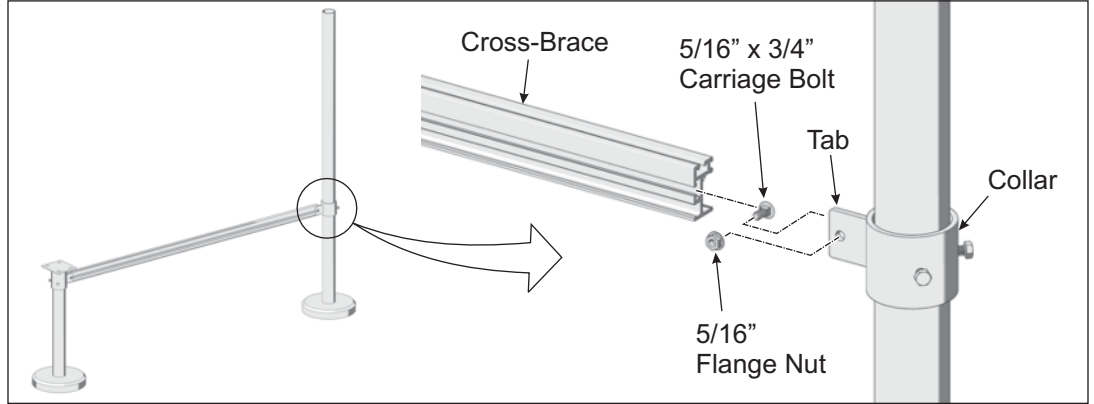

Figure 3-2: Attaching N-S Cross-Bracing to North Collar

Level and Secure Brace

- A. Place Level on Cross-Brace and adjust Collar up or down as needed to level Brace. (See Figure 3-3)
- B. Secure Collar by tightening the two 3/8" Set Bolts. **Torque to 14-16 ft.-lbs.**
- C. Secure Brace by tightening flange nuts at both ends of Brace. **Torque to 14-16 ft.-lbs.**

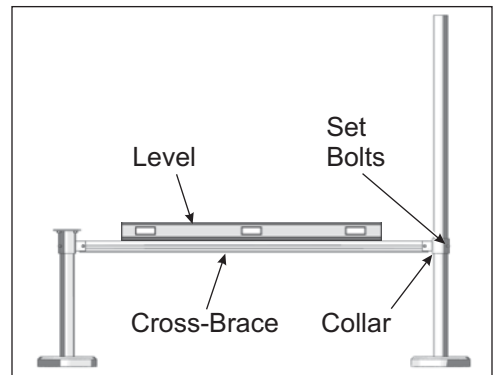

Figure 3-3: Leveling the Brace

Attaching Diagonal Cross-Brace to upper Collar

- A. Slide a 5/16" x 3/4" carriage bolt into the Cross-Brace channel.
- B. Insert the carriage bolt into the Tab mounting hole and secure with 5/16" flange nut. For now, finger tighten only. (See Figure 3-4)

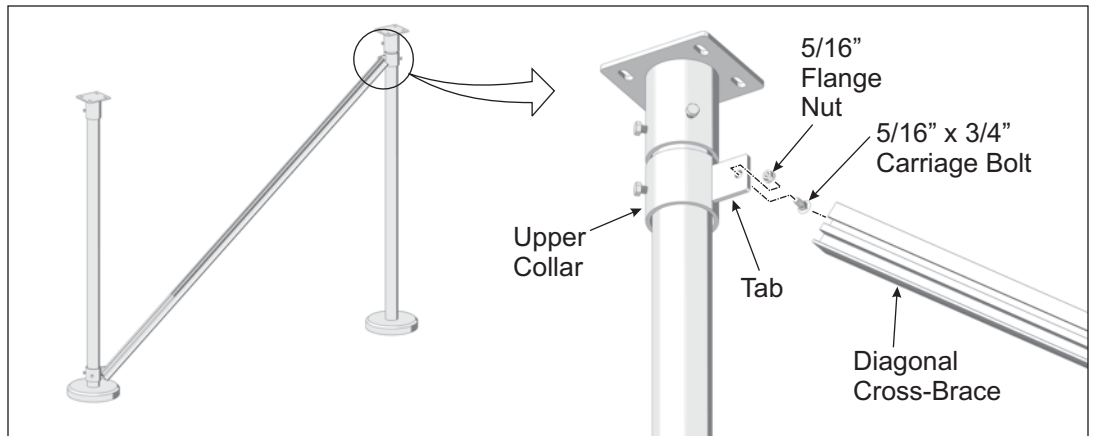

Figure 3-4: Attaching Diagonal Cross-Bracing to Upper Collar

Attaching Cross-Brace to bottom Collar

- A. Slide a 5/16" x 3/4" carriage bolt into the Cross-Brace channel.
- B. Insert the carriage bolt into the Tab mounting hole and secure with 5/16" flange nut. For now, finger tighten only. (See Figure 3-5)

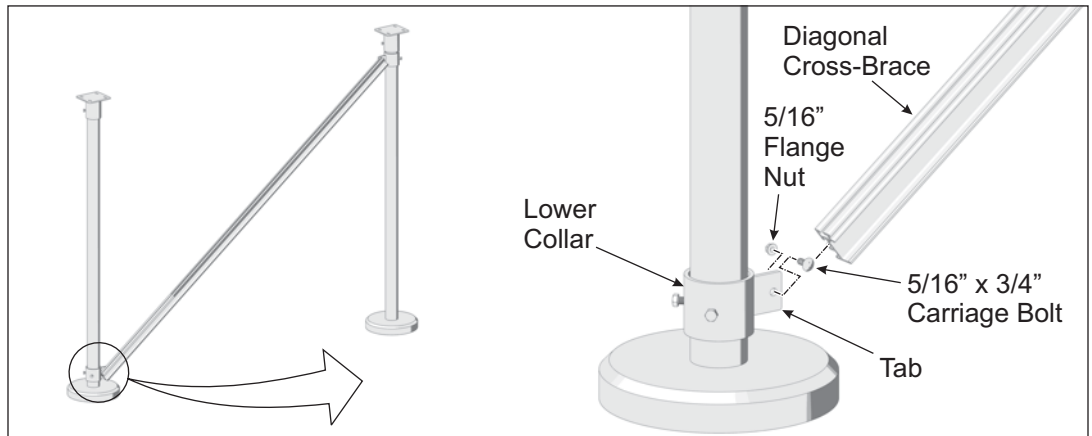

Figure 3-5: Attaching Diagonal Cross-Bracing to Lower Collar

Position and Secure Cross-Brace

- A. Slide upper Collar upward until it butts against the bottom of the Top Sleeve, pulling the Cross-Brace and lower Collar along with it. (See Figure 3-6)
- B. Secure Collars by tightening the two 3/8" Set Bolts on both the upper and lower Collars. **Torque to 14-16 ft.-lbs.**
- C. Center Cross-Brace between Upper and Lower Collars.
- D. Secure Cross-Brace by tightening flange nuts at both ends of Brace. **Torque both to 14-16 ft.-lbs.**

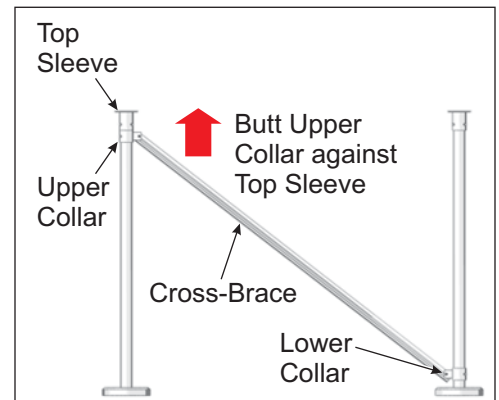

Figure 3-6: Position and secure Diagonal Cross-Bracing

WARNING:

This is a two-person activity. One person should hold the Horizontal Pipe as the other installs the U-bolts and flange nuts. Failure to do so could lead to personal injury.

NOTE:

If any mechanical splicing devices are used on the Horizontal Pipe, avoid resting the splicing device on the Top Sleeves as this could change the elevation of the Horizontal Pipe.

Step 4: Install Horizontal Pipes onto Top Sleeves

Horizontal pipes are secured to the Top Sleeves with two U-bolts and hardware. As the pipe is positioned on the Top Sleeves, there are two important considerations to be aware of. First, any mechanical splicing devices used to splice the pipe must not rest on the Top Sleeves as this can change the pipe elevation from one Top Sleeve to the next, creating additional problems downstream. Second, as the U-bolts are installed, the horizontal pipe will pull the run of Top Sleeves (whose Set Bolts should only be finger tight) into alignment, after which the Top Sleeve Set Bolts will be re-tightened. (See Figures 4-1 and 4-2)

- A. Lift and position the horizontal pipe onto the Top Sleeves, centering it along the E-W run of Top Sleeves. Hold the pipe in place.
 - B. Install two U-bolts over the horizontal pipe and into the Pipe Cap. If needed, rotate the Top Sleeves to align the mounting holes with the U-bolts.
 - C. Secure U-bolts using the provided flat washers, lock washers and hex-nuts. **Torque to 25-30 ft.-lbs.**
 - D. Tighten the two set bolts on each Top Sleeve. **Torque to 14-16 ft.-lbs.** (See Figure 4-2)
- Repeat the above steps for each remaining Top Sleeve.

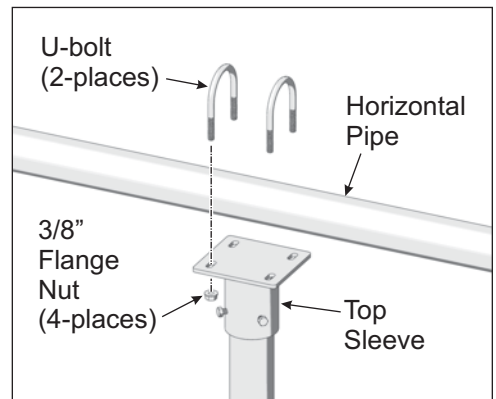

Figure 4-1: Installing Horizontal Pipe

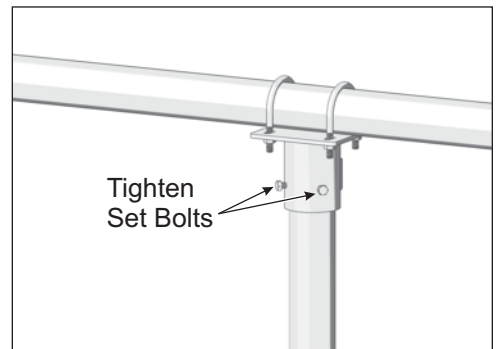

Figure 4-2: Tightening Set Bolts

Step 5: Assemble the Rail Set

Assembly of the Rail Set involves attaching the two Power Rail U-bolt Brackets to the Power Rail. The Power Rail U-bolt Brackets are secured to the Power Rail using 5/16 inch carriage bolts and flange nuts.

- A. Measure the span between the northern and southern Horizontal Pipes. This will be the distance (center-to-center) between the two Power Rail U-bolt Brackets. Divide this dimension in half.
- B. From the mid-point of the Power Rail, measure this distance outwards (in both directions) and make a mark. These marks represent the center location of each of the two Power Rail U-bolt Brackets. (See Figure 5-1)

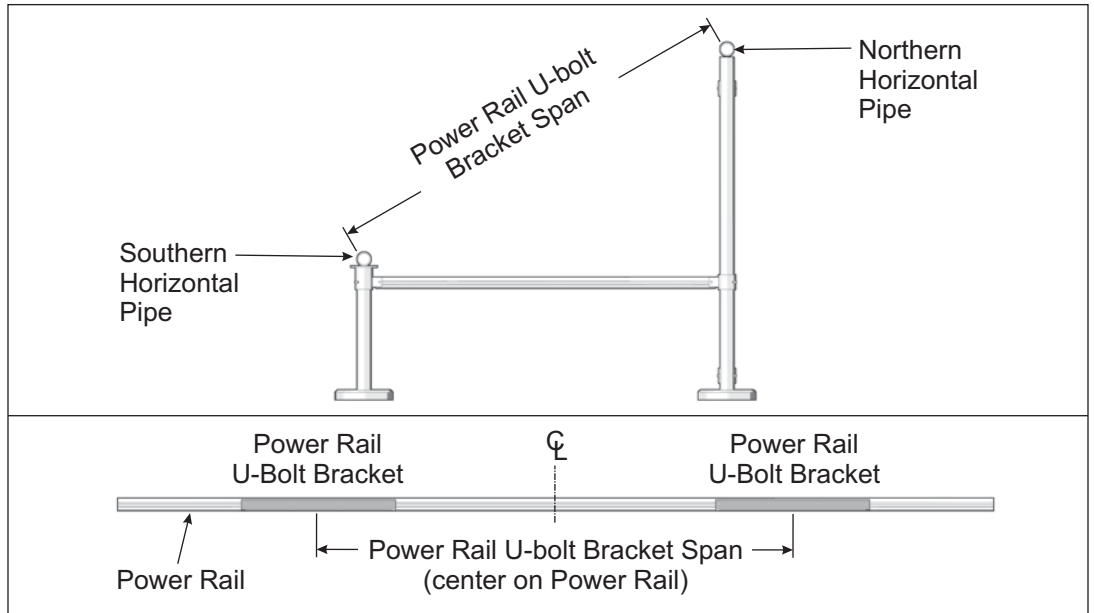

Figure 5-1: Determining the Power Rail U-bolt Bracket Spacing

* Quantity may differ (dependent on site-specific environmental conditions)

- C. Pre-install two sets of four* 5/16" x 3/4" carriage bolts into the Power Rail. One set for each Power Rail U-bolt Bracket. (See Figure 5-2)
- D. Referring to Figure 5-3, orient and align the Power Rail U-bolt Bracket to the previously made center mark on the Power Rail.
- E. Guide each of the four carriage bolts into the four holes of the Power Rail U-bolt Bracket and secure with 5/16" flange nuts. Finger tighten for now as minor adjustments may be required when attaching to the Horizontal Pipes. (See Figure 5-3)

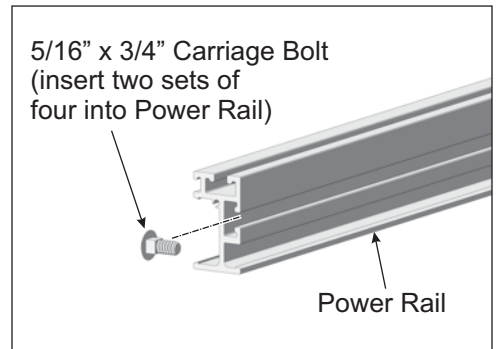

Figure 5-2: Pre-loading Carriage Bolts

NOTE: Be sure that the Rail Bracket is properly oriented to the Module Rail.

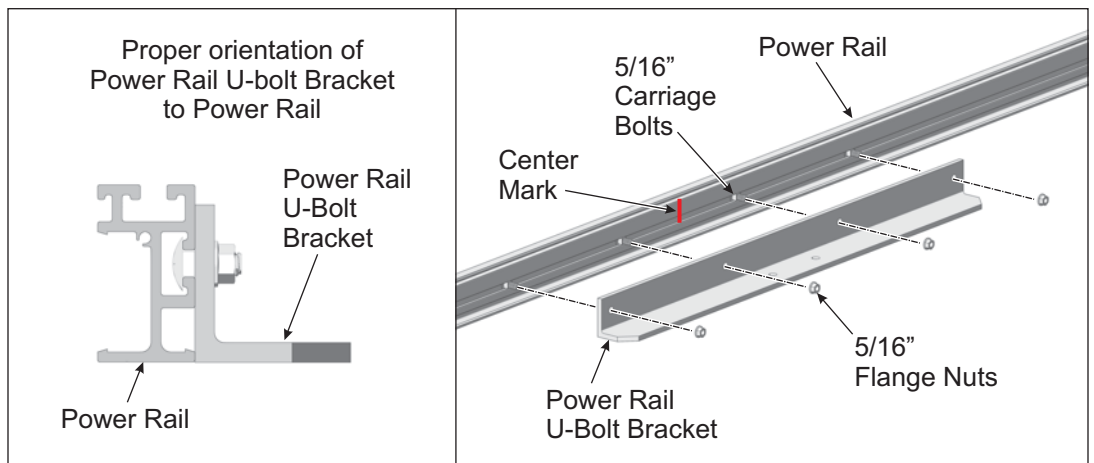

Figure 5-3: Orient and attach Power Rail U-bolt Bracket(s)

WARNING:

This is a two person activity. In addition to the difficulties related to working with a sloped rack, Rail Sets are heavy. One person should hold and align the Rail Set while a second person secures the Rail Set with U-bolts and flange nuts. Failure to do so could lead to serious personal injury and/or damaged components.

NOTE:

Keep the E-W span between the Rail Sets consistent. Make sure the spans at the northern ends match the spans at the southern ends. Keeping the Power Rails parallel and square will simplify the installation of the Modules.

NOTE:

Finger-tighten the Power Rail U-bolt Bracket to the Horizontal Pipe. After the Power Rails are installed and the E-W spacing is set, return and re-tighten to specified torque values.

Step 6: Attaching the Rail Set to the Horizontal Pipes

The Rail Set is attached to the northern and southern horizontal pipe and secured with U-bolts and 3/8" flange nuts. The E-W spacing between Rail Sets along the horizontal pipe is dependent on the module width and the manufacturers' recommendations. Refer to the module manufacturers specifications for E-W spacing requirements.

- A. Place and hold the Rail Set on top of the horizontal pipes. (See Figure 6-1)
 - B. From the underside of the horizontal pipes, align the U-bolt and guide it through the two mounting holes of the Power Rail U-bolt Bracket. Secure with two 3/8 inch flange nuts. Finger tighten for now.
- Repeat the above step to secure the southern-end of the Rail Set to the southern horizontal pipe.
- C. Confirm the E-W positioning of the Rail Sets, and adjust if needed.
 - D. Return and tighten the 5/16" flange nuts. **Torque to 14-16 ft-lbs.**
 - E. Repeat these steps for the remaining Rail Sets.

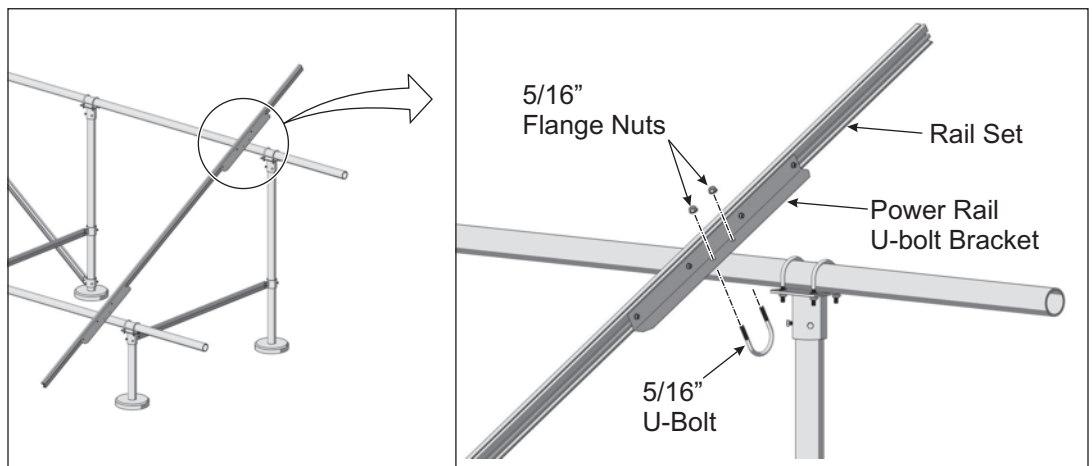

Figure 6-1: Attaching the northern-end of the Rail Set

NOTE:

Because hardware is dependent on particular features and system design, your hardware may appear different from the hardware in these instructions.

WARNING:

This is a two person activity. In addition to the difficulties related to working with a sloped rack, PV Modules are heavy. One person should hold and align the modules while a second person secures modules with clamping hardware. Failure to do so could lead to serious personal injury and/or damaged components.

Step 7: Installing Modules to Power Rails with Module Clamps

Start with the southern most PV Modules and work in a northern direction. This provides a measure of safety as the previously installed southern Modules hold the next in-line northern Module during installation. Modules are secured to the Power Rail using Mid Clamps and End Clamps, both using 5/16" bolts and flange nuts.

These instructions include three options of clamping hardware. They are "Universal End Clamp" (step B1), "Standard End Clamp" (step B2), and "RAD™ Clamps" (step B3).

- A. Place exterior Module on two Power Rails, centering it lengthwise. Use a square to square-up Module to Power Rails.
- B1. For use with "**Universal End Clamps**": Position Universal Clamp underneath module with notches facing the outside edge of the module, and rail centered between 'forks' of the clamp. Slide clamp notches towards module flange until the flange bottoms out in the notches. Tighten 5/16" bolt on bottom of universal end clamp. **Torque to 14-16 ft.-lbs.** Repeat for both end clamps. (See Figure 7-1)

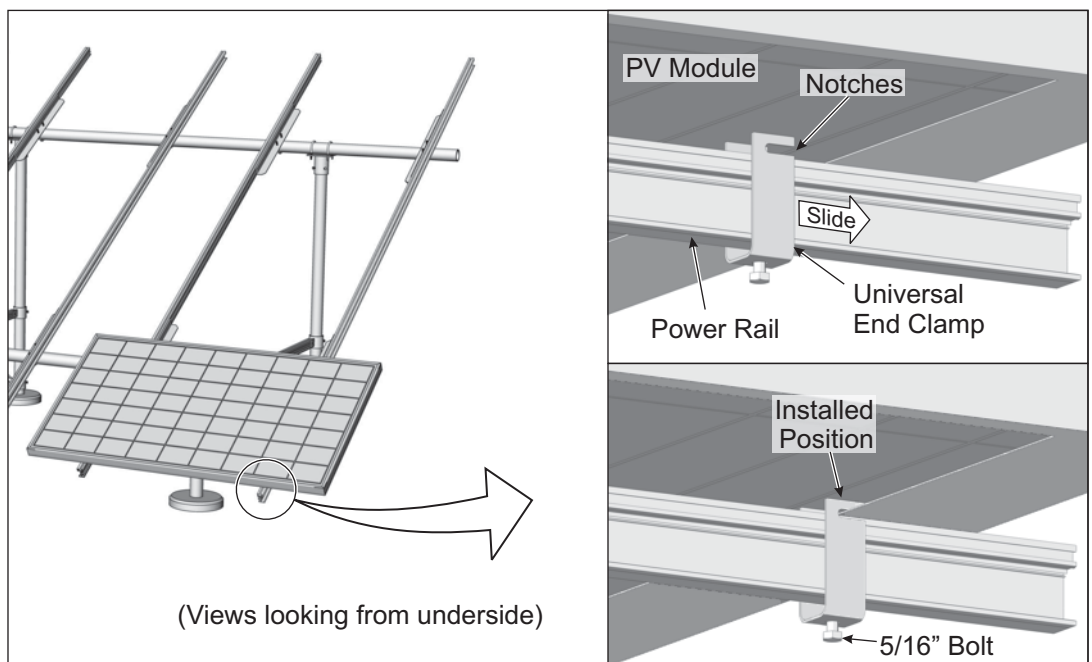

Figure 7-1: Installing PV Modules using Universal End Clamp

- B2. For use with "**Standard End Clamps**". Insert one 5/16" x 2, 2-1/4, 2-1/2, or 2-3/4" carriage bolt into the top slot of the Power Rail. Push the bolt until flush with edge of module frame. Position end clamp with hole facing upwards and center hole over bolt. Seat end clamp over bolt flush with module frame. Thread 5/16" flange nut onto clamp and tighten. When desired alignment is obtained, tighten the nut and end clamp. **Torque End Clamps to 14-16 ft.-lbs.** (See Figure 7-2)

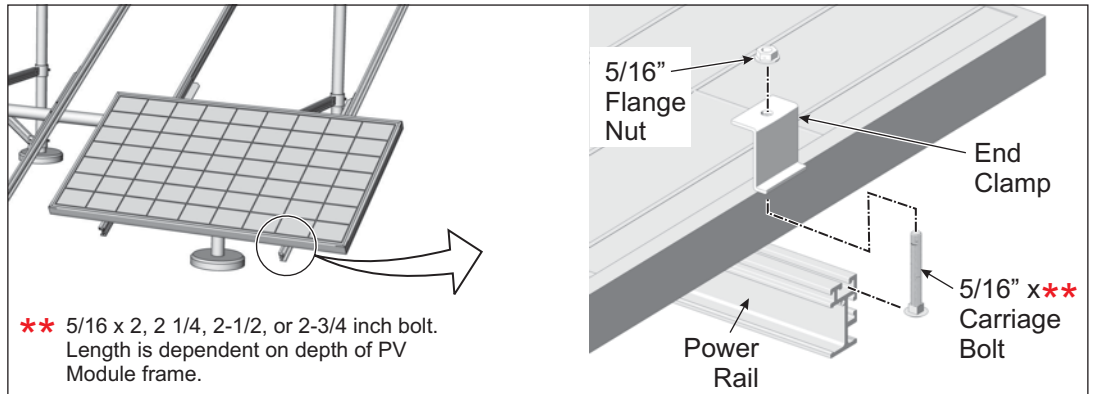

Figure 7-2: Installing PV Modules using Standard End-Clamp

B3. For use with “**RAD Hardware**”. The process is much the same as in step B2 above. The difference is that RAD bolts can be inserted anywhere along the run of Power Rail, not just the ends of the rail as shown in Figure 7-2 above.

Although this step demonstrates installing a *Mid-Clamp*, the procedure for an *End-Clamp* is much the same when using RAD hardware.

Insert RAD bolt into Power Rail and rotate 90-degrees to lock into rail. Install module clamp (End or Mid-Clamp) onto bolt by aligning the flat portion of the clamp with that of the bolt. Thread 5/16" flange nut onto clamp and tighten. When desired alignment is obtained, tighten the nut and end clamp. **Torque End Clamps to 14-16 ft.-lbs.** (See Figure 7-3)

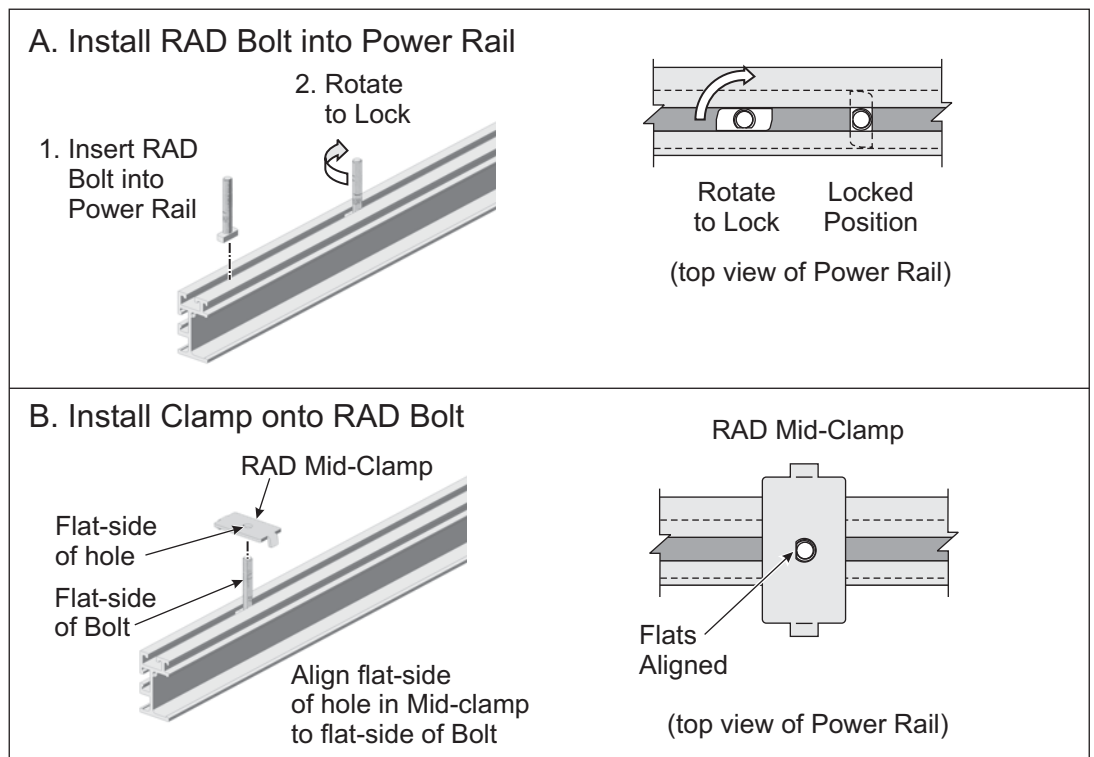

Figure 7-3: Installing PV Modules using RAD Hardware

NOTE:

If using standard 5/16" carriage bolts for Mid Clamps, the bolts must be inserted into Power Rail before installing interior PV Modules.

If using RAD hardware, the hardware can be inserted anytime at any position along the Power Rail.

Installing interior Modules.

- A. Before placing an interior Module onto the Power Rails, first insert 5/16" x 2, 2 1/4, 2 1/2, or 2-3/4 inch carriage bolts (bolt length is dependent on depth of PV Module frame) into the Module Rail, sliding the bolts inward adjacent to the previously installed exterior Module. (See Figure 7-4)

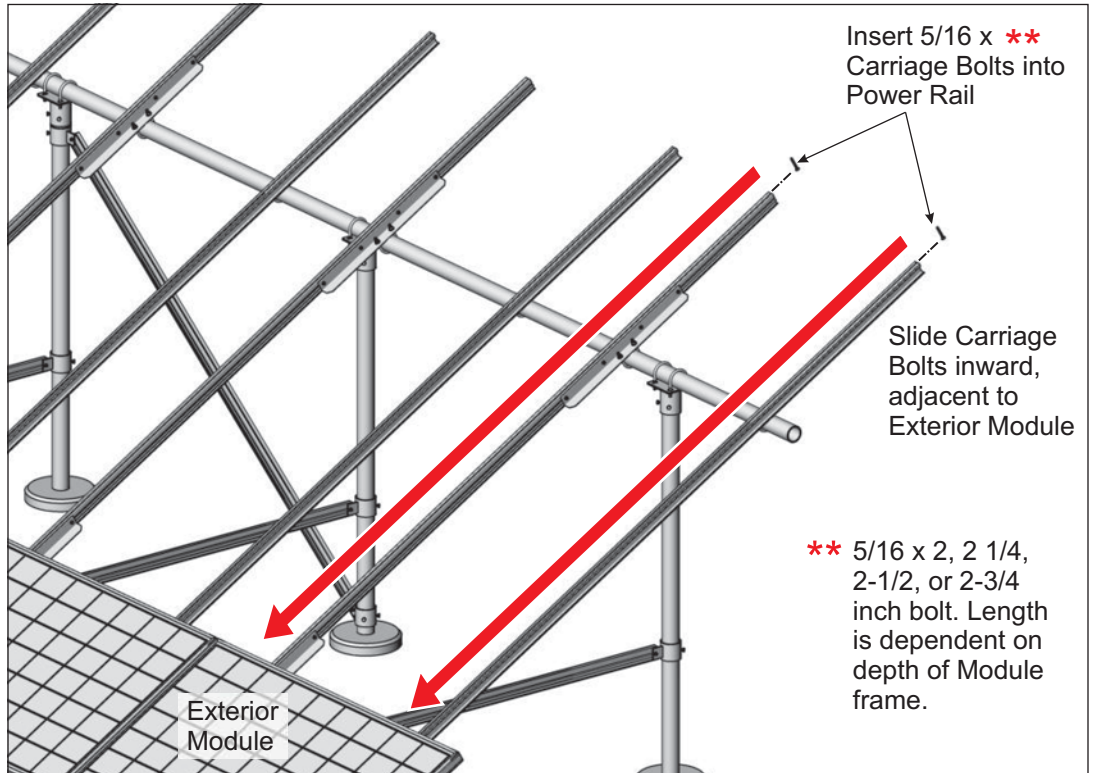

Figure 7-4: Inserting Mid Clamp Hardware into Power Rail

(Continued on next page)

- B. Place the interior Module onto the Power Rails, aligning it with the previously installed exterior Module. Position it adjacent to 5/16" bolts and the previously installed exterior Module.
- C. Use a square to square-up Module to Power Rails.
- D. Install one Mid Clamp on each of the 5/16" bolts that are between each of the interior Modules. Be sure that the tabs of the Mid Clamp rests between the two Modules. Secure each of the Mid Clamps with a 5/16" flange nut. **Torque Mid Clamps to 14-16 ft.-lbs.** (See Figure 7-5)

WARNING:
Be certain that all Flange Nuts on End and Mid Clamps are tightened and torque to the stated values. Failure to do so could lead to serious personal injury and/or damaged components and property.

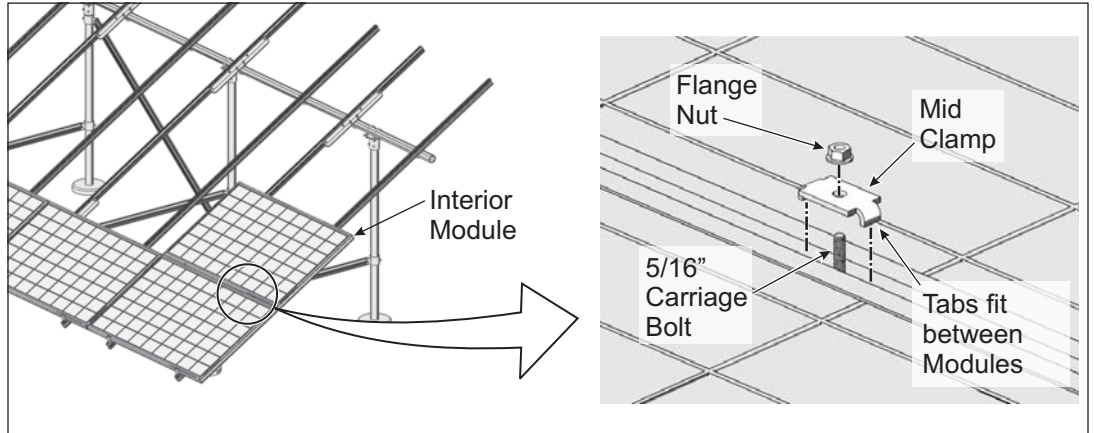

Figure 7-5: Inserting Mid Clamps



4000-B Vassar Drive NE
Albuquerque, New Mexico 87107
USA

Telephone: 800.260.3792
Fax: 505.889.3548
Web Site: www.DPWSolar.com
E-mail: info@power-fab.com

© 2011 Preformed Line Products
PCN 042911-1
Version 1, Rev A