

MidNite Solar E-Panels Explained

When the pre-wired MidNite E-Panels first came out late in 2005, the choices were easy. You were limited to an OutBack inverter and all you had to do was to pick the correct breaker size. Well we've managed to accommodate many dealer and installer requests, but along with these enhancements come additional choices. To help lead you in the right direction, we'll cover different inverters and explore the many options available within each platform.



This is the basic E-Panel made for all of the OutBack inverters. The enclosure is only 9.5 inches wide and 25 inches tall.

The main features are it's small size and low cost. The main drawback is also the small size. The picture here doesn't show it, but the insides have undergone a radical change in the form of individual AC busbars rather than the single AC block. This change allows up to 14 connections per circuit rather than only 5. This enclosure is available as a right hand hinged unit or left (door swing and breakers for a left version are opposite from the right hand version shown)

Another configuration to this series is the availability of an aluminum enclosure vs. the standard steel unit. Steel units are powder coated gray and the aluminum is white. The white aluminum E-Panels are used in places like Hawaii or Maine or wherever salt air is a factor. Aluminum E-Panels also weigh 9 pounds less than the gray steel versions. Some customers just like the look of white, so order aluminum just for that reason.

These E-Panels comes standard with the AC bypass and AC input disconnect pre-wired, din rails for 6 additional 13mm wide AC or DC breakers, battery breaker installed with inverter plus and minus cables, 500 amp/50mV shunt, battery plus busbar, battery minus busbar, AC busbars, ground busbar, DC cover, AC flex conduit tubing with couplers, MX60/Classic mounting bracket, grommets and bushings, numerous knock outs for cable entry and exit, lots of hardware for mounting inverter, charge controller etc, wall mounting brackets, installation instructions, wiring diagram mounted on the door, and a tech support phone number. Check out the before and after pictures below. This person couldn't afford the regular OutBack breaker boxes, so just did without until MidNite came along. These pictures are what it is all about!



User
installed
system

E-Panel
professionally
installed by
Ralph O'Donnal
of GSW systems



Model numbers and descriptions for regular OutBack E-Panels:

MNE125ST	125 amp breaker in the gray steel chassis, Rt hand hinge & breakers
MNE175ST	175 amp breaker in the gray steel chassis, right hand hinge & breakers
MNE250ST	250 amp breaker in the gray steel chassis, right hand hinge & breakers
MNE125AL	125 amp breaker in white alum chassis, right hand hinge & breakers
MNE175AL	175 amp breaker in the white aluminum chassis, right hand hinge and breakers
MNE250AL	250 amp breaker in the white aluminum chassis, right hand hinge and breakers

Add the word "LEFT" to the end of the model number to signify left hand hinge. (example: MNE175AL Left). Note that all E-Panels can be swapped from a right hand unit to a left hand unit in the field. This requires a \$59.00 steel or a \$65.00 aluminum left hand door and a couple hours of work. It is easier to have it built as a left hand unit at the factory where there is no additional charge for a left hand door.

Prices: Basic gray steel 175/250 amp retails for \$479, white aluminum 175/250 amp runs \$519, Basic gray steel 125amp \$439, white alum125 amp \$479

Stretched OutBack E-Panel



Some installers that use a lot of E-Panels have asked for additional room inside the E-Panel. We created the Stretched OB version for these professionals. It is based on the 50% wider Magnum Energy chassis. In addition to more room to work, you also get a PV input busbar, Battery Plus and DC negative busbar. No need for ring terminals anymore with this system! There are also additional knockouts top and bottom for lightning arrestors and cabling. Professionals feel the additional \$70 list price is well worth it.

The PV plus busbar is extremely handy when installing a lightning arrestor to the PV input. That placement is possibly the most important spot for a lightning arrestor and other DC boxes do not accommodate this connection. The PV busbar also makes it easy to bring in up to 1/0 wiring and then reduce to 6AWG to the 63 amp disconnect breaker.

The DC busbar is also very useful for all DC connections like charge control disconnect output, battery status monitor hook up, and a bus to feed DC load breakers.

Model numbers:

MNE175STS

MNE250STS

MNE175STS LEFT

MNE250STS LEFT

Retail \$549

When using the Apollo T80 MPPT controller, be sure to order the Left hand unit. The Apollo has their heatsink on the right side of the unit, so the Left E-Panel is the correct choice. Add the word Apollo to the end of the model number to get a side plate that will accept our 80 amp 125VDC panel mount breakers. 80 amp breakers are sufficient for the T80 because ours are a hydraulic/magnetic design. That means you are allowed per the NEC to actually run 80 amps through the breaker. MNEDC80 breakers are \$20 each. The Apollo kit including two 80 amp breakers and the special side plate for retrofitting an existing 3.5" thick E-Panel retails for \$69.00.

Breakers to fit on din rails

150VDC 13mm wide: 1,6,7,8,10,12,15,20,30,50,63 amps \$13.00 list (example MNEPV15)

150VDC 63 amp (MNDC-GFP) \$69.00 list

120VAC 13mm wide: 10,15, 20 amps UL489 branch circuit rated \$15.00 list (example MNEAC15)

120VAC 13mm wide: 30,40, 50.60 amps UL1077 supplementary protection \$15.00 list (MNEAC50)

277VAC three phase breakers 39mm wide: 30 & 50 amp (MNEAC30-3P) and (MNEAC50-3P) \$54.00 list

Internally used white short face 120VAC UL1077 15, 30 and 50 amp \$15.00 list (MNEAC15 QZD)

Internally used white short face 2 pole 120/240VAC UL1077 50 and 60 amp \$30.00 list (MNEAC50 QZD2)

The Magnum Energy 120VAC E-Panel for MS and RD series

Magnum Energy makes a very interesting line of inverters, both modified and pure sine wave. The RE industry is embracing both types of inverters so MidNite builds E-Panels to accommodate all of the RD and MS series. The insides of the Magnum 120VAC E-Panels look much like the Stretched OutBack. Internal wires are routed to match the Magnum inverter rather than OutBack. The accessory components like the DC cover, top shield, remote bracket and such are Magnum Energy specific. Like the Stretched OB E-Panel, the Magnum has a real PV plus and DC busbar as well as the regular AC input and output busbars. This chassis is 14.4 inches wide, so has ample room for all your wiring needs. The chassis is only 3.5" deep so wiring access is the best in the industry. All of the present 12 and 24 volt Magnum inverters have a 120VAC inverter/charger input/output as well as a 120VAC input/output that does not go through the electronics. It is strictly a pass through for the other leg of a 240VAC input. The pass through leg can be useful when attempting to utilize both legs of a 240VAC generator. One leg is used for charging and the other is used to pass through to your 240VAC deep well pump. The 120VAC E-Panel here is not able to handle the extra leg of AC, so look to the 240 E-Panel to accommodate this unique feature.



Model numbers
 MNE175STM
 MNE250STM
 MNE175STM LEFT
 MNE250STM LEFT

Gray steel chassis
 Price \$549



Magnum all wired up with lightning arrestors, charge control disconnects, DC-GFP and remote display ready for transport to the job site. Note that this picture is of a previous version prior to the addition of the PV plus input busbar.

The picture on the right tells it all. Installers get the chance to assemble the power electronics, inverter, charge controller, breakers, arrestors, battery status monitors, displays etc in the shop. The system as shown here can be tested in the shop to insure that the system is functioning properly. This is one major advantage in using the E-Panel system. These E-Panels can be field modified to be left hand units. A left hand door is required to do this.

Wiring diagram for all 120VAC E-Panels. This diagram also works for the 230VAC export version. The 230VAC E-Panel is wired using blue and brown wire rather than white and black

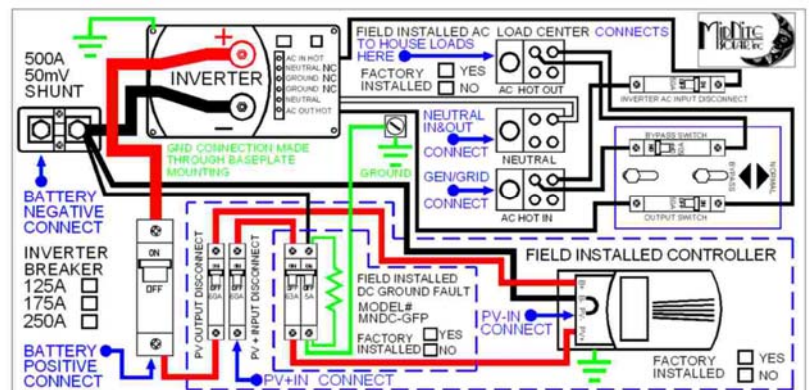

The Magnum Energy 240VAC E-Panel for MS and RD series

This is our flagship E-Panel. It encompasses every suggestion and update we are aware of. It also accommodates the new Magnum Energy MS4448-AE inverter. This inverter is a true 120/240 input and output. Unlike the regular Magnum MS and RD series that have a second 120VAC pass through leg, this new inverter is like having a stacked pair of inverters. It will charge from either a 120VAC source or a 240VAC source. The output is 120/240 just like the utility grid. Compare this system with a stacked pair of inverters (from any company) and you will realize thousands of dollars of savings!.



Features:

- White steel chassis to match the MS series
- Black and red AC input terminal busbars
- Black and red AC output terminal busbars
- Red terminal bus bars for PV+ and Bat+
- Six additional din rail slots
- 500A shunt
- Ground Busbar
- Remote bracket
- Wall mounting brackets
- Inverter cables
- Charge control mounting bracket
- 120/240 AC bypass switch pre-wired
- 120/240 AC input disconnect pre-wired

Model numbers:

- MNE175STM-240 (for MS4448-AE)
- MNE250STM-240 (for MS4024-AE)
- Add the word "LEFT" for left hand hinge

Price \$799.00

The Lite Series



Generic E-Panels for SW, DR or what have you? These do not include inverter cables or charge control brackets.

Model numbers

- MNE125LT \$419
- MNE175LT \$459
- MNE250LT \$459
- MNE125ALT \$459
- MNE175ALT \$499
- MNE250ALT \$499

All Lite's come with left hand doors only. Special Lite's can be made using the wide Magnum sized chassis also. Call for models and pricing.