

Serial No. \_\_\_\_\_

PO-MANU0-0603XX  
February 2008  
Rev.D2



# EXCEL Family OWNER'S MANUAL



**EXCEL**



**EXCEL AC/DC**



Certified to NSF/ANSI Standard 41  
Standard 41  
Certified for liquid containment,  
odors, and solid end products in  
both residential and cottage use



**EXCEL NE**

**RATED CAPACITY**  
**Weekend & Vacation Use**  
6 Adults or families of 8 or  
NE Units; 5 Adults or families of 7  
**Residential & Continuous Use**  
2 Adults or a family of 3 or  
NE Units; 3 Adults or families of 5



Product Info: (905) 332-1314  
E-mail: [compost@sun-mar.com](mailto:compost@sun-mar.com)

Fax: (905) 332-1315

Tech. Service: (888) 341-0782  
<http://www.sun-mar.com>

600 Main St.  
Tonawanda, N.Y.  
14150-0888 U.S.A.

5370 South Service Rd.  
Burlington, ON  
L7L 5L1 CANADA

## **WARRANTY**

SUN-MAR Corp. warrants the original purchaser that this toilet is free from defects in material and workmanship under normal house or cottage use. SUN-MAR Corp. will furnish new parts for any part that fails within three years provided that our inspection shows that such failure is due to defective material or workmanship. Any part supplied by us to replace another part is warranted for the balance of the original warranty period.

This warranty does not cover:

1. Damage resulting from neglect, abuse, accident or alteration; or damage caused by fire, flood, acts of God or any other casualty.
2. Parts and accessories not sold or manufactured by SUN-MAR Corp. or any damage resulting from the use of such items.
3. Damage or failure resulting from failure of the purchaser to follow normal operating procedure outlined in the Owner's Manual or in any other printed instructions.
4. Labor and services charges incurred in the removal and replacement of any parts found defective under the terms of this warranty.
5. All returns to the factory must be made freight prepaid. All shipments from the factory are made F.O.B. the factory.

This warranty is in lieu of all other warranties expressed or implied, and no person is authorized to enlarge our warranty responsibility, which is limited to the terms of this certificate. The Company reserves the right to change, improve or modify its products without obligation to install these improvements on equipment previously manufactured.

## Excel Simple Operating Instructions

### Regular Maintenance

1. Rotate the drum 4-6 rotations every other day while you are there and using the toilet.
2. When rotating the drum, rotations are of the drum itself, not the handle.
3. When finished rotating, fold the handle in under the seat. This will mean that the drum is ready to receive waste, and the drum will not move out of the proper position.
4. After each bowel movement, one cup (250ml) of the bulking mixture should be added to the unit to cover the bowel movement, whichever is greater.
5. If you are leaving for more than three days, unplug the unit.

### Bulking Material

When you run out of our material, you can either purchase our premium mix (Compost Sure) through our offices, or make your own using 60% pine wood shavings and 40% peat moss. The shavings should be no smaller than 1" (25mm) square in size. Do not use cedar. Any other wood will do. Do not use 100% peat moss as this will clog your drum screen and drains.

### Periodic Maintenance

Rake the evaporation chamber (floor of the unit), especially at the two back corners using the tool provided. This is to clear away peat moss from the drains so that they do not get clogged. Do this thoroughly at the beginning and middle of the season for cottage users or bi-monthly if residential, and thereafter if it looks like it needs it (may not need it until the next spring).

Empty some of the contents of the drum into the drawer when the drum is 1/2 full or feels like it is becoming difficult to turn. This is done by pulling out the drum locker and rotating the drum backwards once.

**Attention:** The composting unit must remain plugged in to an electrical outlet continuously and the drum should remain open, ready to receive waste to function odorlessly. The AC/DC units should have both fans running while used in electric mode to prevent recirculation between vent stacks. If you will be away from the residence where the composting unit is installed for longer than three days, the power may be disconnected while the composting unit lays dormant.

## OWNER'S MANUAL

### CONTENTS

<b>Introduction</b>	<b>How your composting toilet Works</b>	<b>4-7</b>	<b>Chapter 4</b>	<b>Compost Troubleshooting</b>	<b>16-19</b>
	How Composting Works	4		Requirements of an Aerobic Compost	16
	The Composting Chamber	4		Compost Too Wet	17
	Compost Finishing Drawer	4		Compost Too Dry	17
	Evaporation Chamber	4		Waste not Breaking Down	17
	Winter Use	5		Lumps	18
	EXCEL Explosion Drawing	6		Drum Too Full	18
	EXCEL Part Numbers	7		Flies	19
	Wiring Diagram	7			
<b>Chapter 1</b>	<b>Inspection</b>	<b>8</b>	<b>Chapter 5</b>	<b>Mechanical Troubleshooting</b>	<b>20-24</b>
	Check for Damage	8		Urine Odor In Washroom	20
	Check for Parts and Functionality	8		Occasional Urine Odor Outside	21
	Attaching the Footrest	8		Sewage Odor when drum turns	21
<b>Chapter 2</b>	<b>Installation</b>	<b>9-11</b>		Fan Noisy	21
	EXCEL Rough in Dimensions	9		Fan Not Working	22
	Included in Your Kit	10		Liquid Buildup/	
	Piping Location	10		Lack of Evaporation	22
	Piping Installation	10		Overflowing Liquid	22
	Leading the vent through the Roof	10		Heating System Not Working	23
	The Diffusor	11		Liquid In Finishing Drawer	24
	Electrical Considerations	11		Drum Will Not Stay Vertical	24
	Drain Installation	11		Drum Will Not Turn	24
	Handling Effluent	11		Drum Door Not Opening/	
	12 Volt Fan Installation	12		Closing	24
<b>Chapter 3</b>	<b>Start Up and Use</b>	<b>13-15</b>		<b>Composting Accessories</b>	<b>25</b>
	Initial System Start Up	13		<b>Simple Instructions</b>	<b>26</b>
	Annual Start Up	14		<b>Warranty Information</b>	<b>27</b>
	Periodic Check Up	14			
	Ongoing Maintenance	15			

## HOW YOUR COMPOSTING TOILET WORKS

*The key to the success of the “EXCEL Family” lies in it’s three chamber design. Each of the three chambers; composting, compost finishing, and evaporation have their own independent environments for optimum efficiency.*

Composting is a natural recycling process where human waste and toilet paper are broken down by microbes into minerals and converted back to earth. Heat, oxygen, organic material and moisture are needed to transform this waste into good fertilizing soil, perfect for your flower beds.

Oxygen is provided by the ventilation system, and by tumbling the composting drum. Additional organic material is introduced by adding “Compost Sure” (or peat moss mix). The waste entering the toilet is approximately 90% water content. Any excess liquid which is not absorbed will collect on the floor of the unit (evaporation chamber) where it may be evaporated into water vapor and carried back to the atmosphere through the venting system. The remaining waste material is transformed into an inoffensive earth-like substance.

### The Composting Chamber

The composting chamber is in the form of a Bio-drum which holds the natural compost heat, provides the necessary mass to maintain a good compost, and is rotated by turning the handle to achieve perfect mixing and aeration.

A drum locker (the white drum locker release button is behind the footrest) automatically maintains the

Bio-drum in a top center position with the drum door open so that the drum is positioned to receive new material.

To mix and aerate, the recessed drum handle beneath the seat at the front of the unit is pulled out and rotated clockwise. Turning this handle clockwise rotates the drum counter-clockwise. As the drum rotates the drum door closes automatically so that the waste remains in the composting drum.

Material is extracted from the drum and into the finishing drawer by pulling the drum lock, and rotating the handle counter-clockwise. The drum turns clockwise, the drum door remains open, and some compost falls into the second chamber; the compost finishing drawer.

### Compost Finishing Drawer

The compost finishing drawer sits tucked away below the step-stool, just above the evaporating chamber. Compost from the drum is isolated in the drawer where it is allowed to ‘finish’ composting. For seasonally used units, several drawers of finished compost are normally removed at the beginning of the season or some composted material can be extracted into the drawer and left there for 3-4 weeks until it is time to remove more compost from the drum.

## ACCESSORY ITEMS FOR COMPOSTING

SUN-MAR has developed a number of composting accessory items over the years in response to frequent requests from users. These items may serve to improve composting speeds under some circumstances.

Name	Description	Container	Price*
<b>“Compost Quick”</b>	Solution containing a mixture of enzymes designed to facilitate bacterial activity. Also useful as a cleaner.	16 oz. (454 gm) spray bottle	\$15.50
<b>“Microbe Mix”</b>	Special selected dried bacteria to decompose waste also includes dried enzymes.	16 oz, (454 gm) Jar	\$16.00
<b>“Compost Sure”</b>	Bulking material containing a mix of coarse peat moss, and chopped hemp stalk to provide moisture retention, porosity, and free air space within the compost.	30 litre (7.9USG) /bag	\$10.00*
* Freight not included in price. Prices subject to change. Please call for current prices before ordering			

### Note:

*If the peat moss you are using is powdery and fine, it will result in poor porosity and an excessively wet, oxygen deficient compost. You should change or modify your bulking material. This situation is most likely to happen with central units which are exposed to a lot of flushing liquid. Modify by adding wood shavings, or use “Compost Sure” for optimum results.*

Electrical Specifications	Excel	Excel NE	Excel AC/DC
Maximum Amps	2.4	NA	2.4/NA
Fan Watts			
(Required or Optional Hook-up)	35 req.	1.4 opt.	35 req./1.4 opt.
Heater Watts (When on)	260	NA	260
Average Power Use In Watts (Heater on 1/2 time)	150	NA	150

Symptom	Cause	Remedial Action	Prevention
<b>Liquid in Finishing Drawer</b>	Drum Screen Clogged	Rotate drum 180 degrees so that the drum screen is on top - you will just be able to see the edge of it if you take out the bowl liner. Scrub screen with wire brush. You may want to hook up your overflow drain beforehand if there is a large liquid buildup in the drum.	
	Unit tilted forward	Use a 1/4" to 1/2" (6-12mm) wedge piece under the front of the unit to raise the front and drain liquid more easily towards the back of the unit.	Install toilet level or tilting slightly backwards, DO NOT install the toilet tilting forwards. If you are unsure of the grade of a bathroom floor, install it with a wedge piece.
<b>Drum Will Not Stay Vertical</b>	Drum Locker Broken	Call Sun-Mar if the problem persists. Have serial number ready and call Sun-Mar for a replacement part.	When returning the drum to top dead center position, do not bang against drum locker with excessive force. Remember to pull out the drum locker button before rotating the drum backwards.
	Drum Catch Broken	(pre-1998 models only)	Not a common repair.
<b>Drum Will Not Turn</b>	Set screw securing handle to shaft has broken	Drill out set screw and replace, or get handle replacement kit (instructions included).	
	Steel roll-pin securing gear wheel to shaft has broken	Have your serial number ready and call Sun-Mar for a replacement Small Gear Kit.	Keep composting drum from becoming overloaded. This puts undue strain on the nylon gear.
<b>Drum Door Not Opening/ Closing Properly</b> <i>(Compost will drop into the finishing drawer even when the drum is not being rotated backwards to extract compost).</i>	Drum fallen from bearings or bearing plate fallen. Drum too full	Have your serial number ready. If the drum or bearing plate has fallen, contact Sun-Mar immediately. We will make sure your problem is fixed quickly.	Not a common repair. Follow items in prevention column for "Drum Too Full" Drum should never be more than 1/2 full.
	Compost encrusted humus deflector	Heavily encrusted humus deflectors, caused by an over-full drum, will push the drum door open with every revolution. The humus deflectors may be accessed by removing the finishing drawer. Use rake to scrape compost from humus deflectors.	
	Hinges Stuck	Drum Hinges have compost caked on them. Spray with Compost Quick and clean with nylon brush. Call Sun-Mar to obtain a replacement drum hinge.	

## Evaporating Chamber

The third chamber is the floor of the Sun-Mar "EXCEL Family" which forms the evaporation chamber from where excess liquids may be evaporated. You will frequently see liquid in this area, which is waiting to be evaporated.

In electric and AC/DC units, air is pulled through intake holes at the rear of the unit; over the evaporating chamber, and up the 2" (50mm) vent stack which exits from the front of the composting unit when AC power is being used.

In the AC mode, the evaporation process is further assisted by a thermostatically controlled heating element in a separate sealed compartment under the evaporating chamber. This heater is on when there is liquid in the evaporating chamber, and mostly off when the chamber is dry. The heating system maintains warmth in the evaporating chamber, and the indirect warmth assists the composting process, without the compost drying out.

In the EXCEL NE natural draft caused by the chimney effect of the 4" (100mm) vent stack draws air into the unit and up the 4" (100mm) vent stack.

A safety drain exits from the back of the composter which drains off any excess liquid to a cess pool, recycling bed, or other approved facility.

## Winter Use

Because "Sun-Mar" units are made largely of fiberglass and high grade stainless steel, freezing temperatures will not damage the composting unit. Composting action decreases as the temperature drops, so for continuous use, the composting unit should be kept constantly at or above 55-60 degrees F (13-15 C). All exposed vent stack should be insulated (right up to 2" or 5cm below the diffusor) to minimize the condensation in the pipe and avoid ice blockages. Drain pipe should be insulated or, in extreme temperatures, heat tape used to prevent ice blockages.

If the toilet is in an unheated space, it may be necessary to keep the unit plugged in and install a fan speed control so that the unit is drawing very little air. Placing a blanket over the unit would also help. These are not ideal composting conditions. Room temperature should be restored as soon as possible for proper composting to occur. In extreme temperatures, an additional source of heat may also be required. If the Excel will be used only occasionally throughout the winter, the toilet may be used as a holding tank with no damage to the unit or the compost. When frozen, the drum should NOT be rotated. Space should be made in the drum to accommodate winter use.

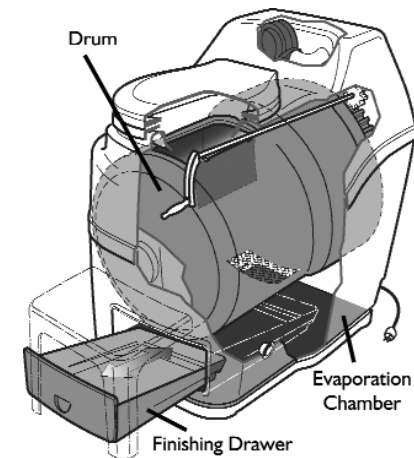

# EXCEL Family EXPLOSION DRAWING

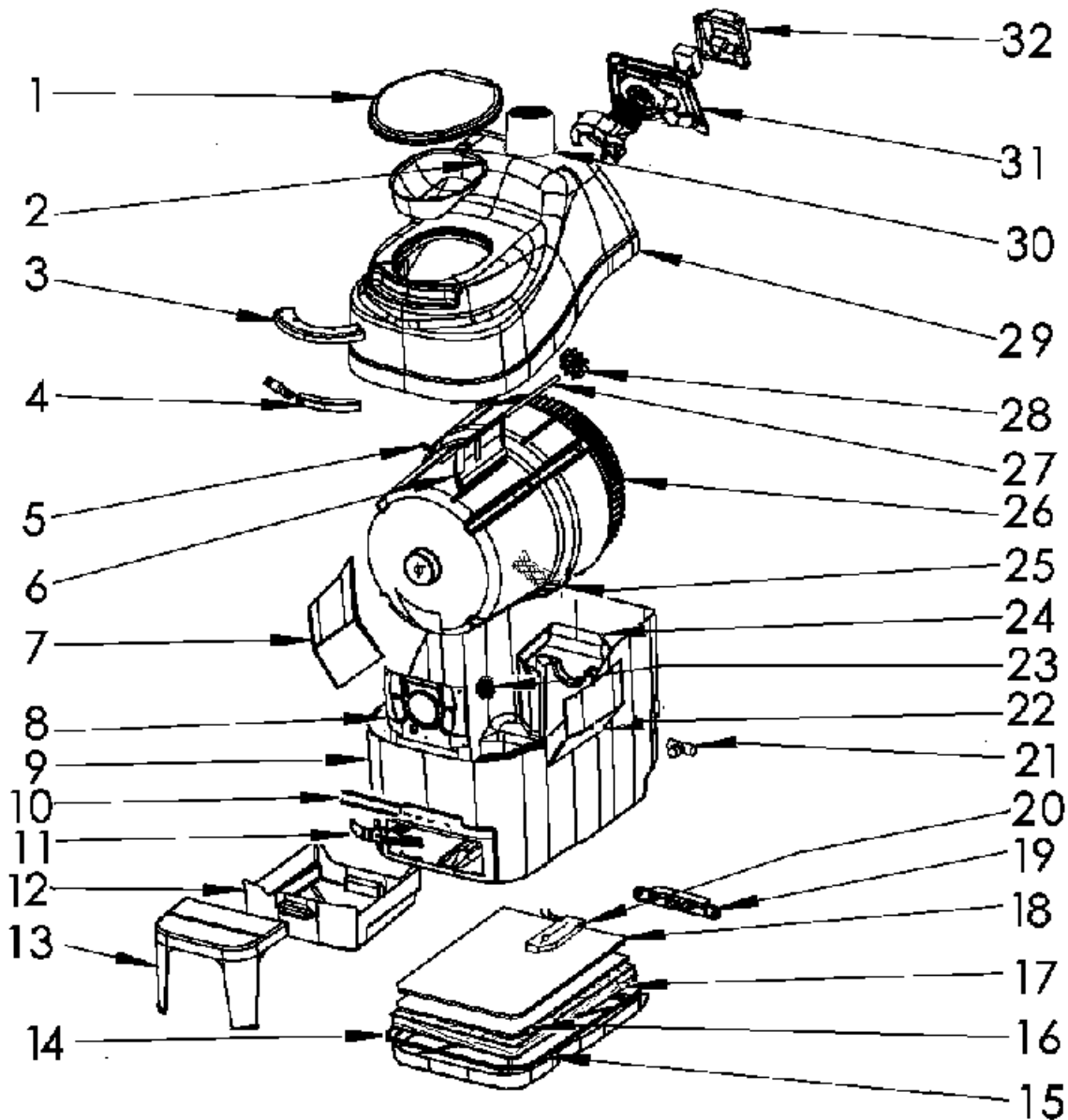

Symptom	Cause	Remedial Action	Prevention
<b>Overflowing Liquid (Cont'd)</b>	Drains Blocked (Cont'd)	<p>2. Check drain line for kinks, blockages or upward bends. Remove and flush if blockages present, unkink if bent and ensure that the drain pipe is sloping downward. If your drain pipe is in order, proceed to step 3.</p> <p>3. Use a wire to poke peat moss out of the drain assembly at the back. You will notice if this is clogged because you will see a brown spot through the opaque assembly. (Only peat would make it through the drum screen). If there is no peat clog, or the problems continue, backwash the unit quickly with a hose by applying the nozzle to one of the drain assemblies and turning it on and off very quickly. If the bottom of the unit is full of liquid, you may wish to remove some prior to back-washing. A shop-vac works well.</p>	<p>2. Use premium 3/4" (18mm) hose for the drain line. A good hose will be less likely to kink. Use elbows or fittings around bends to prevent kinks.</p> <p>3. Use Compost Sure as your bulking material.</p>
<b>Heating System Not Working (Electric &amp; AC/DC) (Cont'd)</b>	Test to determine whether failure has occurred	Pull drawer out and put your hand in the evaporation chamber (Not in the liquid). If there is no warmth rising from the floor of the unit, your heating system is not working. It is most commonly the thermostat that has failed. If you notice a lack of evaporation, but there is still warmth in the heating chamber, see "Liquid Buildup" for solutions.	A ground fault interrupter circuit is recommended to protect your Excel from power surges that could cause your heating system to malfunction.
	Thermostat Failure	Have your serial number ready and call Sun-Mar for a replacement. (Detailed instructions are included with the replacement part)	Your thermostat and fan are the two constantly moving parts on the unit, and so are the most likely to fail. Both are easy to replace.
	Heating Element Failure	<p>If the insulation behind the thermostat access cover is moist or discolored, or heating does not work after the new thermostat has been connected, then the heating element has failed. Have your serial number ready and call Sun-Mar for a replacement. (Detailed instructions are included with the replacement part)</p> <p>Please note: Because this part is not easy to replace, and because there is far less chance that you will need this part than a thermostat; we recommend trying to replace the thermostat first.</p>	If you ever remove the unit from the bathroom for cleaning, DO NOT use a pressure hose around the base of the unit.

Symptom	Cause	Remedial Action	Prevention
<b>Fan Not Working (Electric &amp; AC/DC)</b>	Debris in fan or Mechanical Failure.	Remove the bowl liner and flick the fan blades to ensure that there are no debris blocking the fan blades. If this does not remedy the problem, have your serial number ready and call Sun-Mar.	The fan is a continuously moving part which will eventually have to be changed. Do Not turn on and off daily.
<b>Liquid Buildup/ Lack of Evaporation</b>	Increased usage.	The amount of liquid varies substantially between installations. The overflow drain needs to be installed on the Excel.	Install the overflow drain.  Rake evaporating chamber vigorously at spring startups for cottage use, and once every other month for residential use.
	Climactic conditions	Evaporation rates vary substantially with climate conditions. Expect faster evaporation rates during warm dry weather.	Evaporation will slow during damp weather, make sure drain hose is installed.
<b>Overflowing Liquid</b>	Failure of heating system (Electric & AC/DC)	Check "Heating system not working:."	
	Mineral salts may have accumulated in the evaporation chamber over a few years, reducing evaporation rates.	To get rid of these, fill the evaporation chamber with very hot water and 1/3 bottle of "Compost Quick" enzyme liquid. Leave overnight. - Drain all Liquid through the overflow drain by tipping the unit up (make sure overflow is hooked up first)	
	Overflow drain not hooked up	Connect overflow safety drain (See also increased usage above)	
	Unit tipped forward	Check and ensure that the unit is level or tilting slightly towards the back by placing a 1/4" - 1/2" (6-13mm) shim piece under the front of the unit.	
	Drains Blocked	1. Rake peat moss away from back two corners of Excel and use rake handle to run under the drain baffle to loosen peat moss. These are the "buildup" areas. If drains are still clogged, proceed to step 3.	1. A clogged drain is not very likely to happen if you rake your evaporating chamber every 3-4 months.

## EXCEL Family PART NUMBERS & DESCRIPTIONS

#	PART	DESCRIPTION	#	PART	DESCRIPTION
1	PP-TOILS-0208DX	Toilet Seat Bone	16	AO-HEATE-0320XX	Heating Element (Electric & AC/DC)
1	PP-TOILS-0208CX	Toilet Seat White	17		Insulation
2	PP-BOWLL-0246DX	Bowl Liner	18	PM-ALUMS-0742XX	Aluminum Sheet(Electric & AC/DC)
3	AO-FRONC-0467BX	Front Cover	19	AO-ELECB-0001AX	Electric Box (Electric & AC/DC)
4	AO-HAND0-0307CX	Handle Swivel	20	AO-THERA-0001AX	Thermostat Assembly(Electric & AC/DC)
5	PP-HINGE-0249BX	Plastic Drum Hinges	21	AP-DRAIO-0306XX	Emergency Drain
6	AO-DRUMD-2004XX	Plastic Drum Door	22	PP-DEF_R-0758XX	Humus Deflector Right
7	PP-DEF_L-0757XX	Humus Deflector Left	23	PP-INTAV-0797XX	Air Intake Vent
8	PP-BEARP-0758FX	Front Bearing Plate	24	PP-BEARP-0758RX	Rear Bearing Plate
9	PF-TANKE-0747AX	EXCEL Tank Bone	25	AM-DRUMS-0329XX	Drum Screen
9	PF-TANKE-0747BX	EXCEL Tank White	26	PP-DRUM0-0749XX	EXCEL Drum
9	PF-TANKE-0749AX	EXCEL AC/DC Tank Bone	27	AO-SHAFA-0850BX	EXCEL SS Shaft Assembly(AC/DC)
9	PF-TANKE-0749BX	EXCEL AC/DC Tank White	27	AO-SHAFA-0854XX	EXCEL NE SS Shaft Assembly
9	PF-TANKE-0748AX	EXCEL NE Tank Bone	28	AO-SMALL-0440XX	Nylon Drive Gear
9	PF-TANKE-0748BX	EXCEL NE Tank White	29	PP-TOPOE-0745XX	EXCEL Top Bone
10	PM-CLIP0-0198XX	Footrest Channel	29	PP-TOPOE-0745FX	EXCEL Top White
11	PP-DRUML-0783XX	Drum Locker	29	PP-TOPOE-0745BX	EXCEL NE Top Bone
12	PP-DRAW0-0752PX	Finishing Drawer Bone	29	PP-TOPOE-0745DX	EXCEL NE Top White
12	PP-DRAW0-0752QX	Finishing Drawer White	29	PP-TOPOE-0745CX	EXCEL AC/DC Top Bone
13	PP-FOOT0-0813XX	Footrest Bone	29	PP-TOPOE-0745EX	EXCEL AC/DC Top White
13	PP-FOOT0-0813BX	Footrest White	30	AO-FAN_A-0315CX	Fan Assembly(Electric & AC/DC)
14	PO-GASK0-0188BX	Rubber "U" Channel(Electric & AC/DC)	31	AO-PIPEP-0305XX	4" Inlet Pipe
15	PF-HEATE-0747CX	EXCEL Heater Tray(Electric & AC/DC)	32	PP-FADCE-0754BX	Fan Door Cover(Electric & AC/DC)

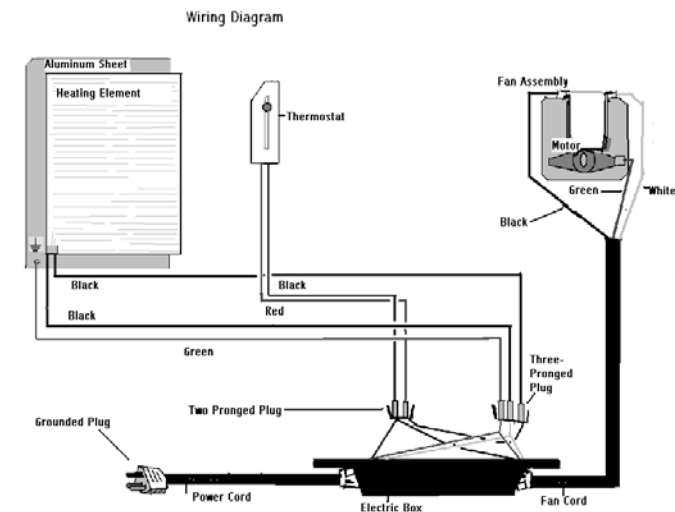

## Chapter 1 Inspection

*his chapter describes how to inspect your new Excel prior to installation for damage and make sure you have received all of the parts.*

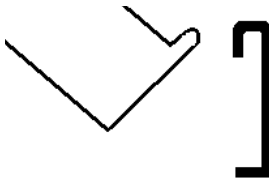
<b>Inspecting the unit for damage</b>	<p><b>i) If there is any visible damage to the carton-</b> the contents of carton MUST be inspected before signing bill of lading. Damaged units should be refused. Call Sun-Mar immediately.</p> <p><b>ii) Before signing the shipping papers and dismissing the driver.-</b> ensure that the carton contents have been inspected.</p> <p><b>iii) If the shipper has left-</b> Report the damage immediately to the transport company and call Sun-Mar.</p> <p><b>iv) Soon after delivery, remove the Excel carefully from the carton-</b> If there is hidden damage, or for any service Questions, contact Sun-Mar to determine the best course of action.</p>
<b>Check Carton Contents and Familiarize Yourself with the Excel</b>	<p>Check to make sure the carton contains everything on the packing list. Notify Sun-Mar if you are missing anything.</p> <p>i) Turn the crank handle clockwise to rotate the Bio-drum for mixing and aeration.</p> <p>ii) Pull the white drum locker button, on the front of the unit (1994 models and on) and turn the crank handle counter-clockwise to simulate extraction of the compost.</p> <p>iii) Plug the unit's electrical cord into a standard 3 prong outlet. Put your hand at the opening to the vent at the top, back of the unit to feel the air movement caused by the fan.</p> <p>iv) Pull out the compost finishing drawer (situated below the drum) where compost drops to finish composting. A Ground Fault Interrupter circuit (GFI) is suggested to protect the electrical system.</p> <p>v) When the unit has been plugged in for 15 minutes, place your hand on the floor of the evaporating chamber (the floor of the unit, under the drawer) to check that it is warm to the touch, so that you know the heater and thermostat are functioning properly.</p>
<b>Attaching and Detaching the footrest</b>	<p>The footrest attaches to the unit via the slot above the drawer. To insert, incline the footrest at a 45 degree angle to the floor as shown. Insert the round top edge of the footrest track on the stool into the round top edge of the track on the unit, and then lower the footrest to the floor. When it is necessary to remove the finishing drawer, the foot rest is removed the same way.</p> <p>Simply lift the footrest until it is at a 45 degree angle and withdraw it from the footrest track.</p> <p>Note: Footrest must be correctly attached before standing on it.</p> 
<b>Space Required Other Considerations</b>	<p>When selecting the best place for your toilet, make sure that there is room (an extra 15" is required) to remove the finishing drawer.</p> <p>The location of the vent stack, and the emergency drain may determine the best place for the toilet. Ensure that the toilet is level front to back or is sloping slightly backwards. The unit should not tip forward. This will ensure that liquid is contained within the unit.</p>

Symptom	Cause	Remedial Action	Prevention
<b>Occasional Urine Odor Outside</b>	<p>1. Vent stack not installed even with peak of roof.</p> <p>2. If vent stack is installed above roofline, natural obstructions, such as tall trees, being located in a valley or close to a hill may be causing down-draft.</p>	<p>1. Check that the vent is installed even with the peak of the roof. If not, extend the vent. Guide wires may be necessary.</p> <p>2. Add lime to the evaporation chamber - as much as you think necessary. You will have to rake more often if you do this. You can also add lime to the compost if desired, but no more than 1/2 (125ml) cup per week as it may upset the PH balance in larger amounts.</p> <p>3. Sun-Mar has a filter box available which will filter the ammonia out of the vented air in a downdraft situation. Call Sun-Mar for details.</p>	<p>Downdraft is dependent on wind direction, as well as natural obstructions, etc.</p> <p>Initially, install the vent level with the peak of the roof. If symptoms occur, add lime or a filter box.</p>
<b>Strong Sewage Odor Present when drum turns</b>	Compost is anaerobic	Begin following: "Compost Troubleshooting" suggestions.	Follow "Ongoing Maintenance" and use proper bulking material.
<b>Fan Noisy (Electric &amp; AC/DC)</b>	Fan damaged in shipping, or bearings are beginning to wear if it is rattling.	<p>1. If it is rattling, it may need to be cleaned or the bearings are worn and the fan needs to be replaced.</p> <p>2. A hum is the normal sound the fan will make. If you are in a very quiet setting it will be more noticeable. If this is the case, consider purchasing a fan speed control so that the fan may be turned down when the noise bothers you.</p> <p>3. If it is a vibration noise, you may need to tie down the top of the stack with guide wires and bracket the pipe that runs up the side of the structure.</p>	<p>Clean the fan with a small brush and/or compressed air nozzle once every 2-3 years in cottage use, or once a year residentially. To do this, remove the fan assembly by taking off the snap cap covers and unscrewing the screws which hold it in.</p> <p>The entire assembly will then simply slide out. This will prevent wear and lengthen the life of your fan.</p>
	Fan (12 Volt) vibrations resonating in	Use pipe clamps to secure vent pipe or install fan with rubberized couplings to help absorb	

Chapter 5  
**MECHANICAL TROUBLE SHOOTING**

Most problems are prevented through proper maintenance and the use of proper bulking materials in the toilet. If you do have a problem which may be a mechanical or installation problem, this Trouble Shooting section will help you solve it. If you still have further questions, contact technical service at Sun-Mar for advice at 1-888-341-0782

Symptom	Cause	Remedial Action	Prevention
<b>Urine Odor in Washroom</b>	Horizontal runs or downward slopes on pipe are causing condensate to block pipe.	Re-install the vent so there are no longer any low points where condensate can collect. If re-installation is not possible, drill a small hole in the bottom of the low point (preferable outdoors) to allow condensate to drain. (Note: watch for icing in winter at this hole.)	Install wall brackets on vent pipe to prevent settling. DO NOT install horizontal runs as liquid will collect and block ventilation, causing odor.
	Fan has failed (110 Volt)(Electric & AC/DC)	Have your serial number ready and call Sun-Mar for a replacement. Instructions are included with the replacement fan.	The fan is a constantly moving part and has a finite service life.
	Device other than Sun-Mar diffuser is installed on top of the vent stack	Wind turbines or vent caps may be discouraging air movement. If so, replace with a Sun-Mar diffuser.	Wind turbines or vent caps should not be installed on or, instead of a Sun-Mar diffuser.
	Room where unit is located is airtight.	1. Hold a lighter up to the air intake holes on either side of the unit. Air should be drawn into both holes. If air is not easily pulled in, check venting for too many bends or horizontal lengths and/or provide more ventilation to the room. 2. Install fresh air intakes on any competing appliances.	Install your Excel in a room with plenty of ventilation and watch for competing appliances such as bathroom fans and wood stoves. A ventilation fan in the bathroom is not required when an Excel is installed.
	Vent stack has too many bends and/or horizontal lengths.	1. Re-install the vent stack to reduce the number of bends/eliminate horizontal lengths. 2. If the vent stack cannot be further straightened, remove the fan assembly and reduce the amount of recirculating air by covering up the area between the fan exhaust and the 90 degree vent intake elbow with duct tape or similar.	Install the vent with minimal bends (total bends should equal no more than 360 degrees) and NO horizontal or downward slopes.
12 volt Fan has failed, or is not running	Remove and replace fan. Fan should be on when installed. When it is turned off it forms an obstruction.	The fan is a constantly moving part and has a finite service life.	

Chapter 2  
**Installation**

**EXCEL Family ROUGH IN DIMENSIONS**

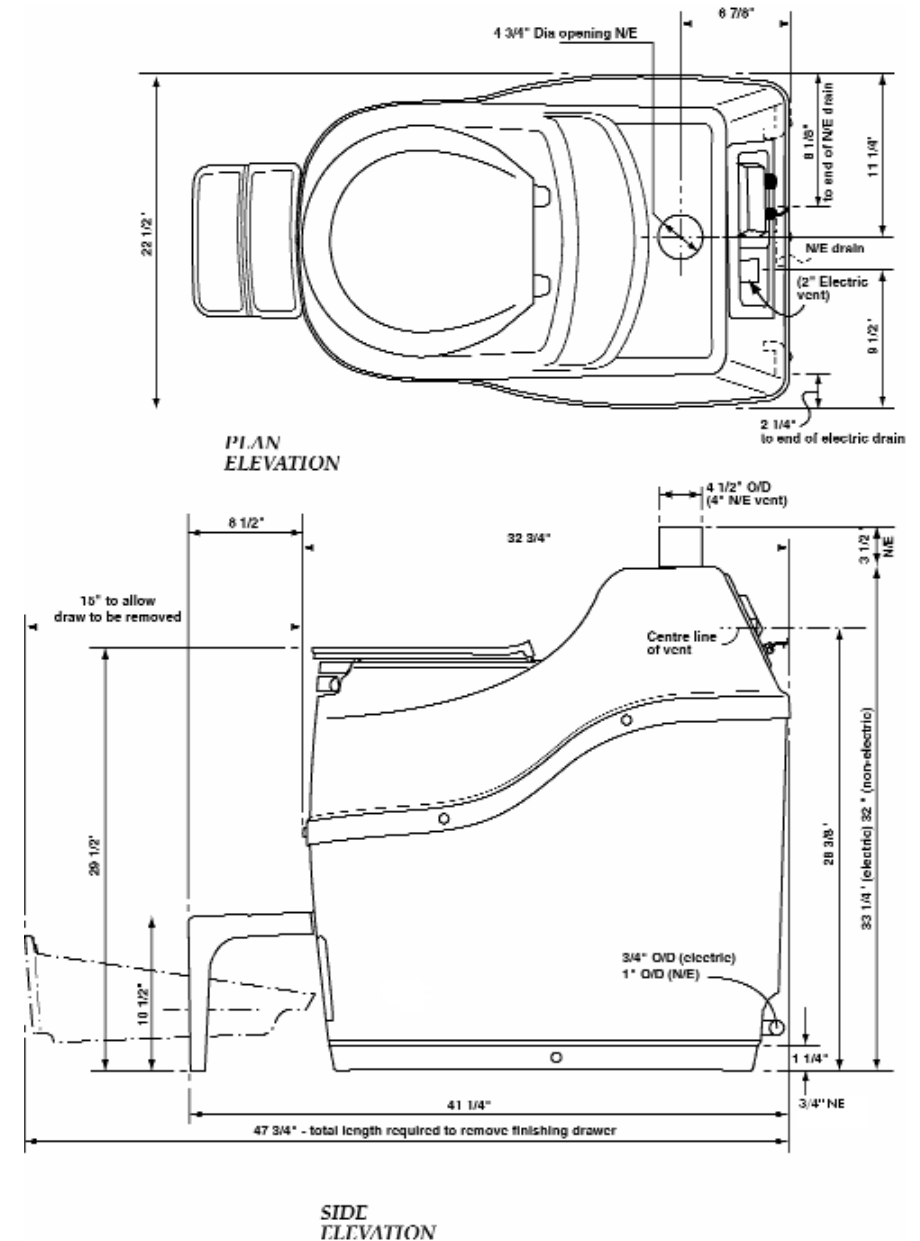

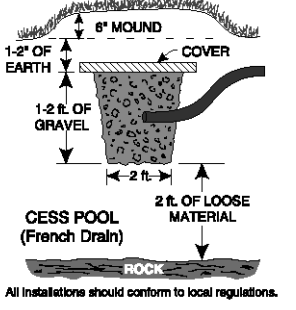
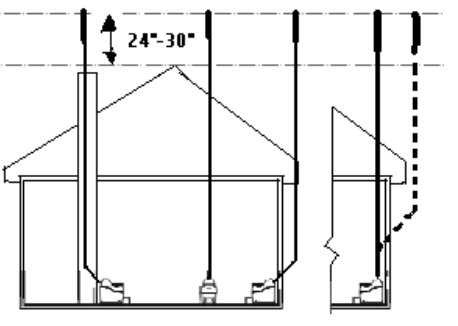
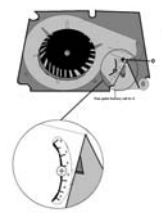
<b>Included in your kit</b>	1- Owners Manual 1- Warranty Card 1- Bowl Liner 1- Footrest 1- Rake 4- 2" x 30" ABS Pipe (Electric & AC/DC) 3- 4" x 31" ABS Pipe (AC/DC & NE) 1- 4" Diffusor (Electric & AC/DC) 1- 6" Diffusor (AC/DC & NE)	1- 1 1/2" Roof Flashing (Electric & AC/DC) 1- 4" Roof Flashing (AC/DC & NE) 1- Excel Hardware Kit (Electric & AC/DC) 1- Excel NE Hardware Kit (AC/DC & NE) 1- 2" Pipe Insulation (Electric & AC/DC) 1- 1" x 10' Drain Pipe (AC/DC & NE) 1- 12 Volt 1.4W Fan (AC/DC) 1- Compost Sure
<b>Handling Effluent</b>	<p>The following are possible options to take care of the liquid (if any) :</p> <ul style="list-style-type: none"> <li>- Use a container which is emptied periodically (water jug or small barrel). This ensures a closed loop system.</li> <li>- Feed into a lined pit filled with gravel and sand. Such a recycling bed also ensures a closed loop system.</li> <li>- Feed into a small cesspit or "french drain".</li> <li>- Plumb into an existing septic or holding tank line.</li> </ul> <p>Installation should be in accordance with applicable local regulations.</p>	
<b>Vent Piping Location</b>	<p>Piping can be installed up the inside wall; through the wall at a slight angle and up the outside wall. The choice depends on ease of installation, visibility, and (especially if the toilet is to be used consistently through a cold winter), the necessity of insulating all exposed vent pipe.</p>	 <p><i>The vent on the right is a 4" non-electric vent. All others show possible 2" vent configurations.</i></p>
<b>Adjusting the fan gate (Electric and AC/DC)</b>	<p>If you believe that there may be a downdraft outside of the building, it may be a good idea to remove your fan assembly prior to installation and set the fan gate to '0' to prevent urine odor in the bathroom. The fan gate is factory set to 3', which recirculates air within the unit. If there is a downdraft you may get blow back into the room where the unit is installed. When setting the fan gate to '0', you may lose some evaporation so it is also wise to hook up the emergency drain.</p>	

Symptom	Cause	Remedial Action	Prevention
<b>Flies Present</b>	<ul style="list-style-type: none"> <li>-compost too dry</li> <li>-compost anaerobic</li> <li>-kitchen/garden waste added</li> <li>-foreign material added</li> </ul>	<ol style="list-style-type: none"> <li>1. To get rid of flies, you can use any pesticide that is used on your garden. Pesticides used for garden use are not anti-bacterial so are safe to use on your compost. If you prefer not to use a pesticide in your compost, the unit should be cleaned out completely and washed with soapy water to kill any remaining eggs. Once the unit is washed, it should be rinsed well to remove all traces of soap before restarting the compost.</li> <li>2. If using a pesticide to kill the insects, it may be purchased from a local garden center or hardware store.</li> <li>3. If using a liquid, sprinkle about 1/2 cup of the mixture directly over the compost. Using a spray bottle, apply throughout the entire toilet (finishing drawer, evaporating chamber, drum, out side of drum) until the fly population is eliminated. Open a window or door to ventilate the room while applying and keep children and pets away from the area for a few hours after application. Repeat if you see another fly after the initial application.</li> </ol> <p><b>IMPORTANT:</b> Application of a pesticide in a Sun-Mar composter is not a health concern because all Sun-Mar units are vented.</p>	<ol style="list-style-type: none"> <li>1. Keep compost moist. In order to determine a good level of moisture, shine a flashlight into the drum. The compost should have a slight gloss or shine. If it does not, add warm water to it until it reaches this consistency. Fungus gnats tend to be attracted to a dry compost, due to the fungus which begins to form on the surface when it dries out. A good, moist compost will not be attractive to flies.</li> <li>2. Do not add topsoil from the ground, composted matter, or kitchen scraps to the toilet. Flies may be present in, or attracted to these items.</li> <li>3. If toilet is installed over an old septic line, make sure that the lines are well sealed. Insects find unused lines attractive.</li> <li>4. See "Compost Remediation" if the compost smells- anaerobic compost will attract flies and drastically reduce the performance of your composting unit</li> <li>5. Use "Compost Sure" or a mixture of peat moss and non-cedar wood shavings.</li> </ol>

Symptom	Cause	Remedial Action	Prevention
<b>Waste not Breaking Down at all(cont'd')</b>	Antibiotics being used for more than a few weeks on a continuous basis may kill bacteria	Empty drum. Hose out inside of drum. Restart compost according to "Initial System Startups".	When used normally, antibiotics will only slightly slow compost. Add Sun-Mar Microbe Mix and/or Compost Quick during this period to accelerate compost action. Urinating elsewhere during this period will also help minimize the damage to the compost.
<b>Lumps</b> <i>If many large lumps have formed in drum, you will need to remove them or break them up with the rake tool. Follow the prevention column to ensure this does not happen.</i>	Compost Too Dry	Follow instructions for "Compost Too Dry" above. And also add 1/2 gallon of wood shavings.	Follow recommendations for checking and adding moisture in "PERIODIC CHECKUP".
	Over-Rotation of Drum	Follow "ONGOING TOILET MAINTENANCE", and also add 1/2 gallon of wood shavings.	Drum should be turned three times a week, 4-6 rotations each time; once before departure for weekend use.
	Peat moss used as bulking material with no wood shavings.	Begin using 60% wood shavings, 40% peat moss as bulking material.	Use proper bulking material.
<b>Drum Too Full</b> <i>Note: The drum is too full when it is over 1/2 full, and the door is not closing properly.</i>	Compost not emptied into finishing drawer in a timely fashion.	1. Remove compost until drum is only half full or less. Rotate compost thoroughly to aerate, and add compost accelerant(Compost Quick and Microbe Mix) if available. 2. If you need to dump more than one drawer of compost, and you do not already have a suitable backyard compost heap, you may try an open-slatted wooden crate (such as the kind used to pack age fruits and vegetables). Layer compost with bulking material and leave crate outside for around 2 months to finish composting.	When drum is 1/2 full, remove some compost to the finishing drawer by rotating the drum backwards, to avoid surprise over-filling of drum. Do NOT let drum get above 1/2 full. (The drum is 1/2 full when the level of the compost reaches 4-6 inches below where the drum door hangs) This will lead to lack of aeration, and anaerobic compost, and the inconvenience of having to remove more than one drawer.
	Kitchen/Garden Waste added		Do Not add kitchen or garden waste.

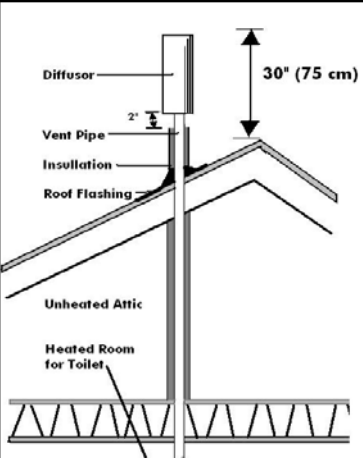
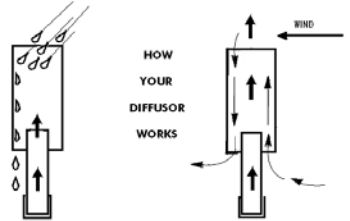
<b>Vent Piping Installation</b>	<p>Piping and fittings are of standard 2" PVC thin wall central vacuum tubing(Electric and AC/DC) and/or 4" PVC thin wall pipe(AC/DC and NE). Additional pipe or fittings can be purchased from a building supply dealer. If you cannot find them near your location, you can substitute schedule 40 pipe and use a rubber coupling to join this pipe to the unit.</p> <ul style="list-style-type: none"> <li>i) Minimize the number of sharp angles in the 2" vent as each reduces vent efficiency. The 4" vent should be installed as near to vertical as possible. On the 4" vent stack, bends should be limited to 2 - 45 degree angles which may necessitate the installation of a 12 volt fan (NE Unit).</li> <li>ii) Do not lead the 2" vent pipe downward or horizontally at any point. This may lead to the vent pipe being blocked by condensation which would cause a urine smell in your bathroom.</li> <li>iii) All connectors in the vent pipe should be sealed. <b>Use silicone for the connection of the vent stack to the toilet in case the composting unit has to be moved or you have to access the fan.</b> PVC cement may be used in the rest of the stack installation if desired.</li> <li>iv) All exposed vent pipe should be insulated with the foam insulation. This is especially important for winter or residential use.</li> <li>v) A 12 volt 1.4 Watt fan is included with the AC/DC unit. The Sun-Mar 12 Volt fan is fitted inside a 12" length of 4" vent pipe for easy installation, should it be needed for the NE unit. It is installed by either cutting out a section of the vent immediately above the composting unit, or by raising the vent stack off of the composting unit and inserting the fan section. The fan can be used with a solar panel and 12 volt battery, or by purchasing a 12 volt adapter from your local hardware store and simply plugging it into the wall.</li> </ul>
<b>Leading the vent through the roof</b>	<p>As shown in the installation, the vent stack should end about 30" above the peak of the roof so that it is less subject to downdraft. Where the piping is taken through the roof, the roof flashing provided should be used to seal the installation. Insert the vent into the bell of the roof flashing and slide the roof flashing down until it lays evenly on the roof. Slip the upper edge of the roof flashing flange under the shingles. Outline the flashing on the roof. Raise the roof flashing and apply silicone sealant or roofing tar inside the outline. Slide the flashing back into place and firmly press onto the sealant. The flashing is properly placed when the top part of the roof flashing flange is tucked under the shingles and the lower portion is sealed on top of the shingles so that water sheds easily. Secure the flashing with corrosion resistant nails at each corner and along sides. Any exposed nails should be sealed with silicone caulking.</p> 
<b>The Diffusor</b>	 <p>The diffusor provided with the unit is a simple device to be installed at the top of the vent stack with the larger pipe protruding above the smaller. To install, simply glue the diffusor on the topmost section of vent pipe. The diffusor design encourages updraft, and discourages wind and weather from going down the vent stack. Unlike wind turbines, diffusors are less likely to freeze up in winter, and are more effective in calm weather.</p>
<b>Electrical Considerations</b>	A ground fault interrupter (GFI) circuit is recommended to protect your composting unit from electrical problems. This may be installed directly on the wall socket or at the circuit breaker.

<p><b>Drain Installation</b></p>	<p>The Excel has a 3/4" OD safety drain that exits from the back right and left of the unit. Although the Excel or the Excel AC/DC have excellent evaporating capacity when used with electricity, the safety drain should be connected for heavy or residential use.</p> <p>Both the NE and AC/DC units have a 1" OD drain that exit from the back of the unit which should be connected as there is the possibility of excess liquid from either of these units.</p>
<p><b>12 Volt Fan Installation (AC/DC)</b></p>	<p>Every Sun-Mar AC/DC model comes with a 12 Volt Fan for installation in the 4" stack. Its installation is required in the following situations:</p> <ul style="list-style-type: none"> <li>-If you are installing both 2" and 4" vent stacks (prevents downdraft from the 2" vent)</li> <li>-If you are in an area where you are subject to downdraft</li> <li>-If you are using the unit residentially</li> <li>-If you need to install the vent stack with bends</li> </ul> <p>We include it because many AC/DC owners do install both vent stacks. It may also be installed later if you wish simply by cutting a section out of your vent and replacing it with the fan.</p> <p>To install the fan initially, pick a spot on the stack that you can reach easily. In order to get the best evaporative performance from the fan, install it near the toilet if possible (remember, the fan will still not be enough to evaporate all liquids in a non-electric or DC only environment). Once you have placed it where you wish, use silicone caulking, or rubberized couplings, to make the installation airtight. Do not use ABS glue at this area as you may need to change the fan at a later date.</p> <p>The 12 Volt Fan may be powered with a battery that is connected to a generator, solar panel, or other alternative energy system. For use in AC, purchase a 12 Volt to AC Adapter from any electrical store and snip off the female end - wire the positive wire to the red wire on the fan, and the negative wire to the blue wire on the fan. Tie them off with small wire connectors, and plug your AC Adapter into the wall.</p> <p>The 12 Volt Fan should be continuously running if used, as if it is not running it will act as a block in the vent stack.</p>

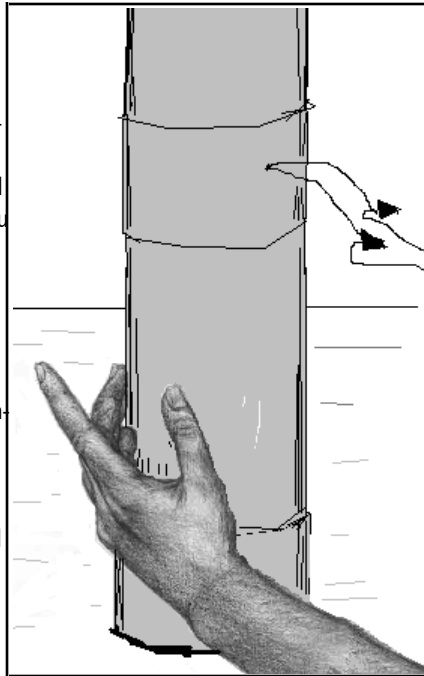

Symptom	Cause	Remedial Action	Prevention
<p><b>Compost Too Wet</b></p> <p><i>Your compost is too wet when there are standing pools of liquid. Compost will smell of sewage and is anaerobic</i></p>	<p>Compost porosity is poor. Too much peat moss has been used as a bulking material. This is compacting, preventing liquid from draining through, and leaving no free air space for oxygen.</p> <p>Drum screen clogged</p>	<p>For an immediate improvement in porosity add about 1/2 gallon of wood shavings, of any kind (except cedar) to the drum.</p> <p>On an ongoing basis, change bulking material to Compost Sure or a half wood shavings and half peat moss mix.</p> <p>Rotate drum 180 degrees so that the drum screen is on top - you will just be able to see the edge of it, with a flashlight, if you take out the bowl liner. Scrub screen with wire brush. You may want to hook up your overflow drain beforehand if there is a large liquid buildup in the drum.</p>	<p>Use Sun-Mar Compost Sure or 40% peat moss, 60% wood shavings as a bulking material.</p>
<p><b>Compost Too Dry</b></p> <p><i>Compost is too dry when compost looks flat and brown rather than rich and black.</i></p>	<p>Moisture not being added periodically or before departure on cottage units. Toilet not used for urination .</p> <p>Insufficient bulking material or not enough peat moss.</p>	<p>Add 1/2 to 1 gallon of hot water to compost in order to bring it up to appropriate moisture level.</p> <p>Peat moss retains moisture. 40-60% moisture content is ideal for aerobic microbes to thrive.</p>	<p>Follow section on moisture in "PERIODIC CHECKUP".</p> <p>Use toilet for urination.</p> <p>Add correct bulking material.</p>
<p><b>Waste not Breaking Down at all</b></p> <p><i>If this is the case, the drum will fill up quickly</i></p>	<p>Insufficient Microbes</p> <p>Room Temperature under 60F/15C</p> <p>Bleach or other anti-bacterial chemicals added.</p>	<p>Add Sun-Mar Microbe Mix or unsterilized black earth from a garden center.</p> <p>Install heat source to increase temperature. Temperature should be kept above 55-60F/15C constantly if toilet will be used on an ongoing basis.</p> <p>Empty drum. Hose out inside of drum. Restart compost according to "Initial System Startups".</p>	<p>Be sure to add microbe packet at startups.</p> <p>Install unit in warm area. The warmer the area, the better your compost will be! If evening temperatures fall below the prescribed temperatures on a residential unit, consider installing a heat source on a timer for evenings.</p> <p>Never add bleach or cleaning chemicals.</p>

## Chapter 4 Compost Troubleshooting

This chapter will deal with problem that may arise with your compost, what is required to make your compost healthy and how to correct problems if they arise.

### Requirements of an Aerobic Compost

In a Sun-Mar, a good compost is predominantly aerobic, which means that oxygen is available for aerobic bacteria throughout the Bio-drum. Aerobic bacteria consume waste quickly and odorlessly to produce carbon dioxide and water vapor and leave behind a small fraction of the original waste volume in the form of basic minerals. The end compost is a mix of valuable minerals and bulking material that has not decomposed.

To work effectively to break down waste, aerobic bacteria need oxygen, moisture, available carbon (from the bulking material), and warmth.

In a Sun-Mar, oxygen is provided by the tumbling of the drum and the bulking material leaving free air space within the compost. Moisture is provided by the waste, and is made available to aerobic bacteria by the moisture retention properties of the bulking material. If the compost is too dry, add warm water.

In summary, to keep the compost aerobic, it is important to rotate the drum, add bulking material, and keep the compost moist.

### Oxygen

Lack of oxygen becomes a problem where:

- Too much moisture eliminates the free air space,
- A lack of bulking material limits free air space,
- Aerobic bacteria use up oxygen in the compost.

Lack of oxygen causes the compost to become increasingly anaerobic, which means that aerobic bacteria are displaced by anaerobic bacteria. Anaerobic bacteria work slowly and produce undesirable ammonia, hydrogen sulphide, and methane. Consequently, the maintenance of 'free air' space by periodically rotating the drum and adding the right bulking material is very important in Sun-Mar units. Excessive rotation is not helpful and can harm the compost by disturbing the bacteria too much.

### Moisture

If there is too much moisture, and the compost is approaching saturation, oxygen is pushed out and anaerobic activity predominates. On the other hand, if there is too little moisture, aerobic activity slows. For this reason, it is important to maintain adequate moisture levels (40-60% moisture content is ideal). Generally, if you shine a flashlight in after mixing, there should be a slight sheen of moisture on your compost.

### Warmth

Too little warmth will cause aerobic activity to slow. Below 55-60 degrees F., microbes will go dormant and composting will stop. Composting speeds increase dramatically with temperature.

### Characteristics of a Bad Compost

If your compost is over 8 weeks old and it exhibits one or more of the following characteristics, then an operating change is indicated.

- ✓ Extraction required too often (under 4 weeks)
- ✓ Large Lumps present in compost
- ✓ Compost muddy or clay-like
- ✓ Flies present (this may also be a problem with foreign matter being added to unit; see section on flies)
- ✓ Compost has strong unpleasant smell of sewage when drum is turned.
- ✓ Toilet paper present in finishing drawer

### Troubleshooting

In using this troubleshooting section, you should follow remedial action in the order that they are given, unless you are sure of the problem. You should see improvement in a week, and your compost should be back to normal in 2-3 weeks. If it is not, make sure that "Ongoing Toilet Maintenance" is being followed and check the mechanical troubleshooting section.

## Chapter 3 Start Up and Use

Although the start up instructions remain the same no matter what your application, different situations will require different actions and this chapter will explain what they are.

### Initial System Start Up

Begin operation by carrying out the start up procedure described below, and then continue with the "Ongoing Toilet Maintenance" routine. It normally takes six weeks before a compost is properly established. You will know this has happened when:

- **Compost Volume increases more slowly**
- **Compost turns black and becomes loam-like**
- **Toilet paper decomposes within a few days**

	Action	Why?
<b>ADD</b>	3-4 gallons of peat mix (half the 30 liter bag provided) to the drum.	-Provides carbon base and initial mass for compost.
<b>ADD</b>	1/2 Microbe Mix packet at start up, other 1/2 in two weeks	-Adds necessary microbes which will breakdown the compost.
<b>SPRINKLE</b>	About 1/2 gallon of warm water into the drum	-Moistens carbon base
<b>PLUG IN</b>	Fan and heater are operating	-The unit is ready for use
<b>SPRAY</b>	"Compost Quick" enzymes into drum before and after mixing. Coat the evaporation chamber with it before using the unit.	-Speeds start up of compost by acting as a catalyst to assist bacteria. -Prevents possibility of start-up odor in the evaporating chamber.
<b>RAKE</b>	Loose peat moss from the evaporating chamber until the compost is established, which takes approximately 6 weeks.	-Until the compost is active, some peat moss may fall through the screen or drum door into the evaporating chamber

\* Toilet paper is a good source of carbon and should be added after use.

## Annual Start Up (seasonal units only)

Many units are only used regularly throughout the summer. For such seasonal units Sun-Mar recommends that the following start up procedure be followed at the beginning of the season.

Action	Reason for Action
<b>Empty</b> the compost that had been left in the finishing drawer, and use the rake to clean out the evaporation chamber.	- <i>Your fertilizer is ready.</i> - <i>This is a good time to remove peat debris</i>
<b>Remove</b> additional drawers of compost (if there is more than 4- 6" or 100-150mm in the drum), by releasing the drum lock (white button under foot stool), and rotating the drum clockwise (the handle turns counter-clockwise) to extract compost into the drawer. (At the beginning of the season, it will all be finished compost) Empty the drawer and repeat extraction cycle until the level in the drum is reduced to about 6" (150mm)	- <i>Frees space in the composting ] chamber for the new seasons composting.</i>
<b>Add</b> 1/2 gallon (2 liter) of warm water.	- <i>Raises moisture level</i>
<b>As an option for optimal composting,</b> Add SUN-MAR "Microbe Mix". We do not recommend using topsoil as it may contain fly larvae.  SUN-MAR "Compost Quick" enzyme can also be used as a compost accelerant.	- <i>Even though the compost still has microbes in it, you may want to start the year by replenishing your batch of microbes.</i>  - <i>Compost Quick helps to accelerate the action of the microbes.</i>

## Periodic Check Up

Once your unit has been through initial or annual startups, and ongoing maintenance procedures are being followed, Sun-Mar recommends a system of periodic checks be undertaken.

Action	Reason for Action
<b>Rake</b> peat moss debris from the evaporation chamber, making sure to rake from the rear of the chamber, including the back two corners of the unit. Raking should occur on a yearly basis for cottages (best done at annual startups), and a bi-monthly period for continuous users. This is ideally done when the floor of the unit is dry.	- <i>Ensures drains cannot get plugged and evaporation is improved.</i>
<b>Check</b> your compost moisture level on each visit for cottage users and once every two weeks for continuous users. This can be done by shining a light into the Bio-Drum. The compost should have a slight gloss or shine to it. A moisture meter may also be used if so desired. Range should be 4-6, which represents 40% to 60%	- <i>A good compost is between 40% and 60% moisture content.</i>  - <i>Prevents lumps, ensures toilet paper breaks down quickly.</i>  - <i>Prevents insects</i>

## Ongoing Toilet Maintenance

The procedure below is designed to keep the compost:

- **Moist, but not too wet**
- **Well aerated and mixed**
- **Well balanced and aerobic**

Action	Reason for Action
<b>Add</b> 1 cupful (250ml) of Sun-Mar Compost Sure (or mixture of 40% peat moss and 60% non-cedar wood shavings) to the Bio-Drum after every bowel movement. This usually represents one cupful per person per day of use.	- Maintains the carbon/nitrogen balance - Absorbs liquid - Helps oxygen penetrate for aerobic composting
<b>Turn Handle</b> to rotate the drum 6 complete revolutions of the drum, three times per week when in use, or, if used only at weekends, only on departure.	- Mixes and oxygenates the compost
<b>Unplug</b> the unit if you are leaving for a period of more than a few days. If you are leaving one weekend and coming back the next, you may unplug the unit. Consider installing a timer to shut the unit off after 48 hours to evaporate excess liquid. If you are leaving for a period of more than a few days, or the compost appears dry, add approximately 1/2 gallon(2 liters) of warm water to keep the compost moist.	- unplugging unit will conserve power and keep compost from drying.  - addition of water helps keep the compost moist
<b>Extract</b> some compost into the finishing drawer when the drum is 1/2 full. It is 1/2 full when the compost reaches a level about 4-6 inches (100-150mm) below the drum door when the door is open. To empty some compost into the drawer, pull the drum locker button and rotate the handle counter-clockwise (to turn the drum clockwise). Turn at the same speed you would normally do for mixing. If necessary, use the rake to level the compost in the drawer. Leave the compost in the finishing drawer to finish for 3-4 weeks or until you next need to remove compost from the drum. We recommend storing compost in a container before using.	- Moves some compost to the next stage for finishing  - Ensures that the drum does not get too full  - Provides extra time for composting to be completed
<b>If your unit is used seasonally and is not used heavily, you may not have to remove any compost at all during the season. If so, follow "Annual Startups".</b>	

## **CAUTION**

1. Do **NOT** add or clean the toilet bowl with chemicals. Chemicals will kill the bacteria.  
**INSTEAD**, clean the bowl liner with "Compost Quick", or very hot water and baking soda.
2. Do **NOT** add plastic, glass, metal, cleaning fluids, cigarettes. Add only waste and bulking material.
3. Kitchen or garden waste are **NOT** recommended.